

THE INHIBITOR-OF-APOPTOSIS PROTEIN SURVIVIN INCREASES P34CDC2
PHOSPHORYLATION AND ENHANCES CELL SURVIVAL AND
PROLIFERATION BY PROTECTING THE WEE1 KINASE FROM DEGRADATION
BY CASPASE-3

Javier Rivera Guzman

Submitted to the faculty of the University Graduate School
in partial fulfillment of the requirements
for the degree
Doctor of Philosophy
in the Department of Microbiology and Immunology,
Indiana University

August 2009

Accepted by the Faculty of Indiana University, in partial fulfillment of the requirements for the degree of Doctor of Philosophy

Louis M. Pelus, Ph.D.
Committee Chairman

Hal E. Broxmeyer, Ph.D.

Doctoral Committee

Johnny He, Ph.D.

June 16, 2009

Harikrishna Nakshatri, Ph.D.

This work is dedicated to my friends and family for their continuing support and to my God for the strength to persevere.

ACKNOWLEDGEMENTS

I would like to thank Yahaira Naaldijk, Yaritzabel Roman, Catherine Steding, Erin Goldblatt, Tabitha Hardy and Lissa Smith and all the other friends that I have made while here in Indianapolis for your support and understanding throughout this journey of scientific learning and personal growth. There is no way I could have made it through without you.

To Dr. Louis Pelus, thank you for the having me in your laboratory though the circumstances were not ideal and taking me under your wing and helping me grow as a scientist and as a person. I appreciate your patience with me more than you will ever know.

To Dr. Seiji Fukuda, thank you for your guidance and your expertise and helping me develop my project through the initial phases.

To Drs. Hal Broxmeyer and Ann Roman, thank you for your support from day one of interviews before I was even accepted to the program and for your understanding and encouragement throughout this experience.

To Dr. Harikrishna Nakshatri, who has been on my committees from the first time I formed them, I will always be grateful for your expertise and suggestions throughout my entire graduate career.

To Dr. Johnny He, thank you for serving on my committee and your questions and critical eye.

To Sandi Wilson, Cindy Booth, Audrey Carson and Janis Stringer, thank you for taking care of me ever since I entered the program, all your warm support and good advice will always mean the world to me.

Lastly but not least, I want to thank the wonderful postdocs I have had the honor of working with through the years here: Drs. Roxanna Pincheira (my guardian angel), Pratibah Singh and Janardhan Sampath for your help and guidance. I find myself very fortunate to have been your colleague and at times your student.

ABSTRACT

Javier Rivera Guzman

THE INHIBITOR-OF-APOPTOSIS PROTEIN SURVIVIN INCREASES P34CDC2
PHOSPHORYLATION AND ENHANCES CELL SURVIVAL AND
PROLIFERATION BY PROTECTING THE WEE1 KINASE FROM DEGRADATION
BY CASPASE-3

The anti-apoptotic protein Survivin and the cyclin-dependent kinase p34Cdc2 are involved in cell cycle progression and apoptosis. Activation of Cdc2 is required for its pro-apoptotic activity, which can be inhibited by phosphorylation at Tyrosine-15 (Tyr15). In transduced IL-3-dependent murine BaF3 hematopoietic cells, over-expression of wild-type-(wt)-Survivin increased Cdc2-Tyr15 phosphorylation, while over-expression of a dominant-negative-(dn)-T34A-Survivin construct decreased its phosphorylation. The increased phospho-Tyr15 levels associated with ectopic Survivin directly correlated with enhanced BaF3 cell survival in the absence of growth factors, and low phospho-Tyr15 levels observed in cells expressing ectopic dn-Survivin correlated with decreased survival. BaF3 cells transduced with Internal Tandem Duplication (ITD) mutations of the Flt3 receptor that results in increased Survivin levels, also contained increased levels of Tyr15 phosphorylated Cdc2. In BaF3 cells over-expressing wt-Survivin, 2-fold higher levels of Wee1 protein were observed compared to cells expressing control vector alone.

Treatment of control BaF3 cells with the caspase-3 inhibitor Ac-DEVD-CHO increased both Cdc2-Tyr15 phosphorylation and Wee1 protein levels. In a similar fashion over-expression of wt-Survivin in these cells maintained high levels of Tyr15 phosphorylated Cdc2 and Wee1 protein. In MCF7 human breast cancer cells that lack caspase-3, increase of Tyr15 phosphorylated Cdc2 and Wee1 kinase protein by caspase-3, -7 or a pan-caspase inhibitor was absent, linking Survivin and caspase-3 to the increase of Wee1 and Tyr15 phosphorylation of Cdc2. To further link Survivin and Cdc2, we treated cells with AICAR and 17-AAG that inhibit Hsp90, which is known to be required for Survivin stability. Treatment of BaF3 cells expressing wt-Survivin with AICAR and 17-AAG decreased Cdc2-Tyr15 phosphorylation compared to vehicle-treated control cells. Taken together, these results indicate that Survivin protects the Cdc2-Tyr15-targeting kinase Wee1 from degradation by caspase-3 which leads to increased inhibitory Cdc2-Tyr15 phosphorylation resulting in reduced apoptosis and enhanced survival.

Louis M. Pelus, Ph.D.
Committee Chairman

TABLE OF CONTENTS

List of Figures.....	xi
Abbreviations	xiii
Introduction.....	1
Survivin.....	1
Structure and Function.....	1
Splice Variants.....	2
Role in Apoptosis.....	9
Role in Cell Cycle.....	12
Role in Hematopoiesis.....	13
Target of Cancer Therapeutics.....	14
Hematopoiesis.....	15
Overview.....	15
Markers/Definitions.....	15
P34Cdc2/CDK1	18
Role in Cell Cycle.....	18
Role in Apoptosis.....	21
Cell Cycle.....	21
Overview.....	21
Cell Cycle Arrest and Cell Cycle Checkpoints.....	26
Apoptosis.....	26

Overview.....	26
Intrinsic Pathway.....	27
Extrinsic Pathway.....	27
Caspases-3, -7 and -9.....	30
Wee1 Kinase.....	33
Structure, Function and Role in Cell Cycle	33
Role in Apoptosis.....	33
Purpose of This Study.....	34
Materials and Methods.....	35
Cell Lines.....	35
Transduction.....	36
Antibodies and Reagents.....	36
Cell Lysis and Immunoblotting.....	36
Immunoprecipitation.....	37
Treatments.....	38
Flow Cytometry.....	39
Statistics.....	39
Results.....	40
Chapter 1: Survivin Maintains Phosphorylation of p34Cdc2 at Tyrosine-15	40
Over-Expression of Survivin Correlates with Survival and Elevated Phospho-Tyr15-Cdc2 Levels	40

Phospho-Tyr15-Cdc2 Levels are Not Due to An Increase in S-Phase	54
Wt-Survivin Does Not Directly Interact with Wee1 Kinase.....	54
Wt-Survivin Increases Wee1 Kinase Protein Levels.....	57
Chapter 2: Survivin Protects Wee1 Kinase.....	62
Survivin Over-Expression is Sufficient to Maintain Phospho-Tyr15- Cdc2 and Wee1 Protein Levels	62
Caspase-3 is Required to Cause a Change to Wee1 Levels.....	67
Destabilization of Survivin Abrogates the Effect on Wee1.....	70
p21 ^{cip1/waf1} is Elevated in wt-Survivin Over-Expressing BaF3 Cells	75
Unified Model of Survivin-mediated Increase in phospho-Tyr15- Cdc2 and Inhibition of Apoptosis	80
Discussion.....	83
Summary.....	87
Future Studies.....	89
References.....	91
Curriculum Vitae	

FIGURES

Figure 1. Wild-Type Survivin Protein Structure and Protein-Protein Interaction Sites....	3
Figure 2. Survivin Splice Variant Exon Structures	5
Figure 3. The Apoptosome	10
Figure 4. The Hierarchy of Hematopoiesis	16
Figure 5. Cdc2 and Cell Cycle	19
Figure 6. Cdc2 and Apoptosis.....	22
Figure 7. Cell Cycle	24
Figure 8. The Intrinsic and Extrinsic Pathways of Apoptosis.....	28
Figure 9. Caspase Structures and Domains.....	31
Figure 10. Early Apoptotic Index of the BaF3-Transduced Cell Lines.....	41
Figure 11. Viable Cell Counts of the BaF3 Cell Lines	43
Figure 12. Active Caspase-3 Assay	45
Figure 13. Protein Profile of the BaF3 Cell Lines	47
Figure 14. Cdc2-Tyr15 Phosphorylation is Elevated in BaF3 Cells Expressing ITD- Flt3 mutants.....	50
Figure 15. ITD-Flt3 BaF3 Cells Show Increased Cdc2-Tyr15 Phosphorylation and Cell Survival	52
Figure 16. Cell Cycle Analysis	55
Figure 17. Immunoprecipitation of Survivin and Wee1 from Human Jurkat T-Cells	58
Figure 18. Wee1 Kinase is Elevated in wt-Survivin Over-Expressing Cells	60

Figure 19. Ac-DEVD-CHO Concentration Curve Increase Directly Correlates with Increased Phospho-Tyr15-Cdc2	63
Figure 20. Survivin Over-Expression is Sufficient to Maintain Phospho-Tyr15-Cdc2 Levels	65
Figure 21. Pharmacological Inhibition with Other Caspase Inhibitors	68
Figure 22. Treatment of MC7 Cells with Caspase Inhibitors Has No Effect on Phospho-Tyr15-Cdc2 or Wee1 Protein Levels	71
Figure 23. Inhibition of Hsp90 by AICAR Treatment Decreases Phospho-Tyr15- Cdc2 Levels in wt-Survivin Over-Expressing Cells	73
Figure 24. 17-AAG Treatment of wt-Survivin Over-Expressing BaF3 Cells	76
Figure 25. P21 ^{Cip1/Waf1} Protein Elevation Correlates with Increased Survivin and Phospho-Tyr15-Cdc2 Levels	78
Figure 26. A Unifying Model of Survivin's Effect on Cdc2 Inactivation and Inhibition of Apoptosis	81

ABBREVIATIONS

Ac-DEVD-CHO	N-acetyl-Asp-Glu-Val-Asp-CHO
Ac-LEHD-CHO	N-acetyl-Leu-Glu-His-Asp-CHO
AML	Acute myeloid leukemia
Apaf-1	Apoptotic protease-activating factor-1
APC	Anaphase promoting complex
BIR	Baculoviral inhibitor-of-apoptosis repeat
CAD	Caspase-activated deoxyribonuclease
CARD	Caspase recruitment domain
Caspase	CysteinyI aspartate proteinase
CD	Cluster designation
Cdk1	Cyclin-dependent kinase 1
Cdk2	Cyclin-dependent kinase 2
Cdk4	Cyclin-dependent kinase 4
CDKI	Cyclin-dependent kinase inhibitor
CED	Cell death proteins
CLP	Common lymphoid progenitor cell
CMP	Common myeloid progenitor cell
CPC	Chromosomal passenger complex
DED	Death effector domain
DIABLO	Direct IAP binding protein with low pI

DISC	Death inducing signaling complex
dn	Dominant-negative
Erk	Extracellular signal regulated kinase
FACS	Fluorescence-activated cell sorting
FADD	Fas receptor-associated death domain
FasL	Fas ligand
FasR	Fas Receptor
FBS	Fetal bovine serum
FL	Flt3 ligand
G ₂ /M	G ₂ /Mitosis
GMP	Granulocyte/Macrophage progenitor cell
HSC	Hematopoietic stem cell
Hsp90	Heat shock protein-90
IAP	Inhibitor of apoptosis
iCAD	Inhibitor of caspase-activated deoxyribonuclease
ITD	Internal tandem duplication
Lin	Lineage
MAPK	Mitogen-activated protein kinase
MEF	Mouse embryo fibroblast
MEP	Megakaryocytic/Erythroid progenitor
MPF	Mitosis promoting factor

mRNA	Messenger ribonucleic acid
NES	Nuclear export signal
PARP	Poly (ADP-ribose) polymerase
PI3K	Phosphoinositol-3-kinase
pRB	Retinoblastoma protein
SCF	Stem cell factor
SDS-PAGE	Sodium dodecyl sulfate polyacrylamide gel electrophoresis
Smac	Second mitochondria-derived activator of caspases
T34A	Threonine-34-to-Alanine
TIAP	Thymus/testis-specific IAP
TNF- α	Tumor necrosis factor-alpha
TPO	Thrombopoietin
TRADD	Tumor necrosis factor receptor-associated death domain
UCB	Umbilical cord blood
wt	Wild-type
Z-VAD-FMK	Z-Val-Ala-Asp(OCH ₃)-Fluoromethylketone

INTRODUCTION

Survivin

Structure and Function

Survivin is a member of the inhibitor of apoptosis (IAP) family of endogenous anti-apoptotic proteins characterized by the presence of a baculoviral inhibitor of apoptosis repeat (BIR) domain [1, 2] that inhibits caspase activity. Survivin was originally found to be highly expressed in cancer and fetal tissues but absent in differentiated adult tissues. However, more recent studies show that Survivin is expressed in a number of non-terminally differentiated adult tissues particularly those characterized by a high degree of proliferation and/or self-renewal such as hematopoietic stem cells, neuronal stem cells, keratinocyte stem cells [3-6] and T-cells. In mice, Survivin is also known as thymus/testis-specific IAP (TIAP) [7]. Survivin plays a regulatory role in both evasion of apoptosis and cell cycle progression [8]. Survivin expression is highly upregulated in virtually all solid tumors and leukemias and is usually associated with more aggressive disease and resistance to chemotherapy [9]. The fact that Survivin is highly over-expressed in cancer cells with limited expression in normal tissues has made it an attractive target for cancer therapy [10]. Although Survivin can provide cells with a proliferative advantage, its over-expression alone does not appear sufficient to confer growth factor-independence or transformation [7, 11, 12].

The Survivin gene (Birc5) is approximately 14.7 kilobases in length and has been localized to chromosome 17q25 [13]. It contains a TATA-less promoter rich in Sp1

binding sites, which are required for basal gene transcription [14, 15]. This gene encodes a wild-type Survivin protein that is approximately 16.5 kilodaltons in size and forms a homodimer which is thought to be necessary for its antiapoptotic function [16, 17]. Phosphorylation of Threonine-34 by the Cdc2/Cyclin B1 heterodimeric kinase is believed to be necessary for Survivin dimerization [18]. Survivin has a number of known direct binding partners including CRM1, Smac/DIABLO, INCENP, Borealin, Aurora kinase B and Hsp90 [19-24]. Figure 1 shows an overview of the protein structure and protein-protein interactions of wild-type Survivin [10].

Splice Variants

To date approximately 14 splice variants of the Survivin gene have been reported including Survivin, 2B, Δ Ex3, 3B and 2 α [9]. Figure 2 shows the exon splicing of wild-type Survivin and the variants 2 α , 2B, Δ Ex3 and 3B [10, 25]. These variants have been reported to exhibit differing functions with different subcellular localizations [26, 27]. Whereas variants Δ Ex3 and 3B are considered to be anti-apoptotic, similar to wt-Survivin (albeit 3B is reported to be more potent than Δ Ex3), variants 2B and 2 α are considered to be pro-apoptotic, although this is still in debate and some investigators prefer to term it “non-antiapoptotic” [28, 29]. Our laboratory has also identified two novel splice variants, Survivin 3G and 3G-variant that have anti-apoptotic activity equal to wt-Survivin but expressed at higher levels in hematopoietic stem cells (unpublished data).

Figure 1

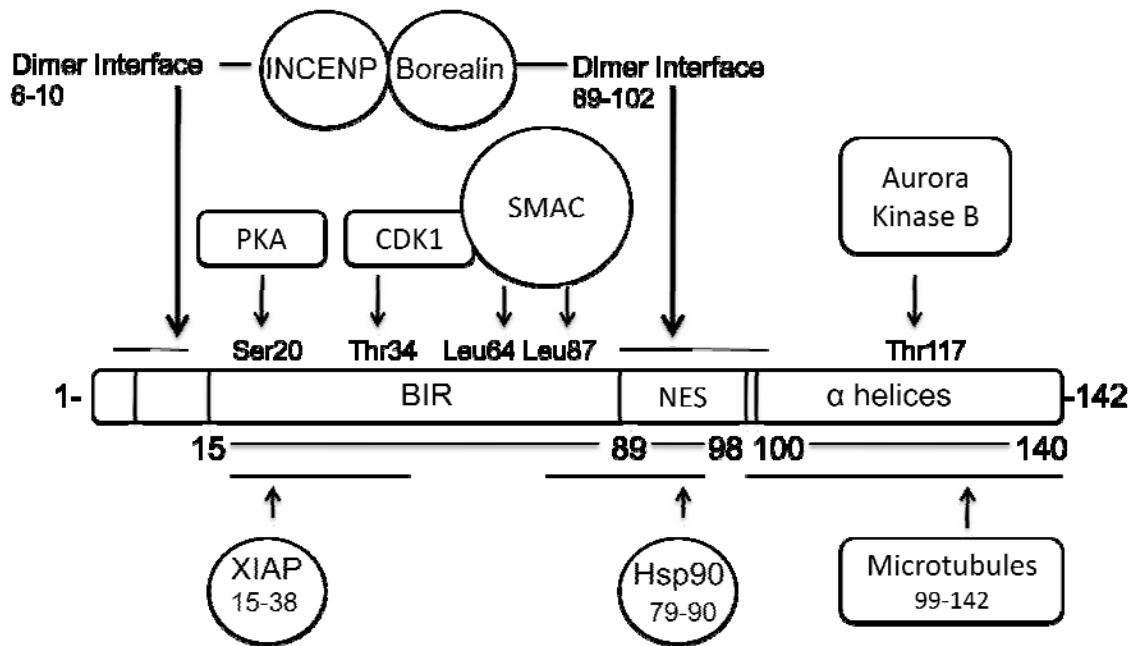

Adapted from Altieri, D.C., 2008 [10]

Figure 1. Wild-Type Survivin Protein Structure and Protein-Protein Interaction

Sites. Schematic representation of the wild-type Survivin protein showing its known function domains, baculovirus IAP repeat (BIR), nuclear export signal (NES) and alpha-helices, as well as binding partners and their binding sites (arrows): INCENP, Borealin, SMAC, X-linked IAP (IAP), heat shock protein 90 (Hsp90) and Aurora Kinase B. Phosphorylated residues (arrow followed by residue) indicate phosphorylation sites by known kinases: Cdk1 (also known as p34Cdc2) at Threonine-34, Aurora kinase B at Threonine-117 and Protein Kinase A at Serine-20.

Figure 2

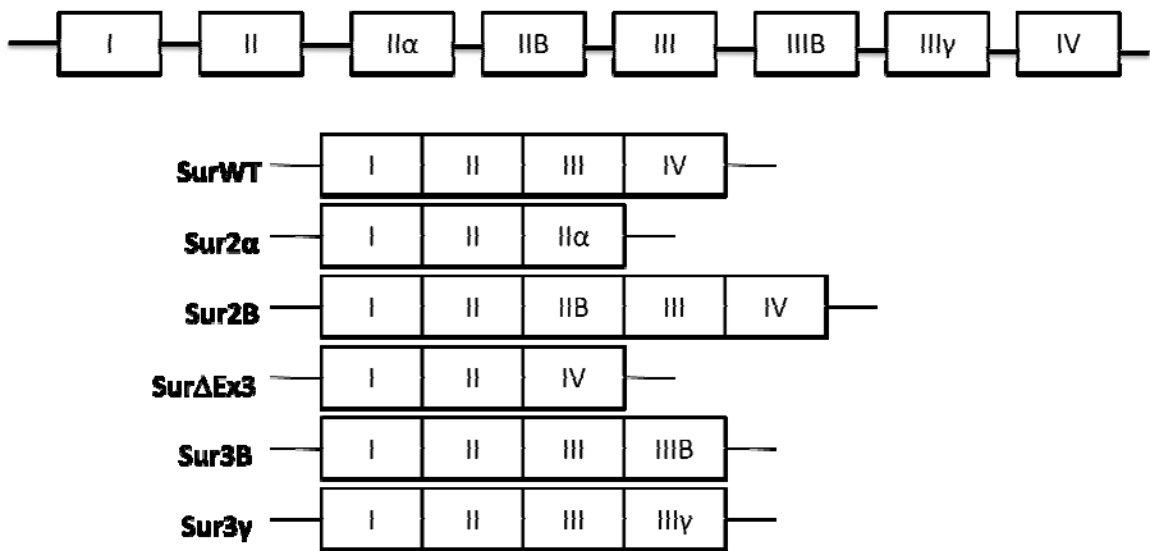

Adapted from Sampath, J. and Pelus, L.M., 2007[9]

Figure 2. Survivin Splice Variant Exon Structures. The top diagram shows the order of the exons in the Survivin gene (boxes) from Exon I to Exon IV. The bottom diagram represents the exons and designation of Survivin splice variants that have been reported and their mature protein verified: wt-Survivin, Survivin 2 α , Survivin 2B, Survivin Δ Ex3, Survivin 3B and Survivin 3 γ ; this excludes variants simply identified from EST database searches or RT-PCR.

There has been an ongoing effort to determine the role of the Survivin splice variants in cancer [30]. Early studies suggested that expression of the Survivin 2B variant may have a negative role on cancer progression and malignancy. A high level of expression of Survivin 2B was associated with good prognosis in patients with neuroblastoma and lower expression is associated with malignant tissues [31]. Survivin 2B expression is lower in later stages of renal cell carcinomas [32] and inversely proportional to tumor differentiation and invasion in gastric cancer [33] and dominant in some benign brain tumors [34]. The Survivin splice variant Δ Ex3 has been reported to have the opposite effect to Survivin 2B and inversely proportional to apoptotic index [35]. High levels of Survivin Δ Ex3 mRNA have been reported to correlate with high proliferative activity in hepatocellular carcinoma [36]. In patients with breast carcinomas, Survivin variants 2B, Δ Ex3 and 3B have been detected, and while Survivin 2B was detected at higher levels in small tumors, 3B was more frequent in high-grade carcinomas and was more frequent in tumors with p53 gene mutation [37]. Relatively little is known about variant Survivin 2-alpha (2α) in cancer, however recent studies have shown that there is no change in Survivin 2α expression between paracancerous and cancerous tissues in gastric cancer patients [38]. In contrast, Survivin 2α expression was elevated in therapy resistant breast carcinoma cells [39]. However, with the identification of 10 new splice variants in addition to those discussed above it is now clear that the primers and probes used to detect the Survivin splice variants evaluated for activity to

date are not sufficiently specific and will detect more than one variant. As a consequence, previously reported correlations may be inaccurate.

Although the subcellular localization of wild-type Survivin affects its function in cells, how subcellular localization affects the function of individual Survivin splice variants is relatively unknown and is currently being investigated. The Survivin 2B variant has been found to be expressed mainly in the cytosol and a small fraction in the mitochondria [26, 40]. This latter finding may be important because Survivin 2B, which can bind wt- Survivin, may prevent its release from the mitochondria and in turn prevent inhibition of caspase-9 mediated apoptosis [41, 42]. In contrast, the Δ Ex3 Survivin variant appears to localize mainly to the nucleus [26] as well as to the nucleoli, where it is degraded [43], and only a small portion localizes to the mitochondria [40]. During mitosis, Survivin Δ Ex3 appears to translocate to the mitotic spindles [42], however the effect of its subcellular localization and its function have yet to be elucidated. Survivin 2 α appears to localize to both the nucleus and cytoplasm during interphase but remains in the cytoplasm during mitosis [44]. Little is known about the subcellular localization of the recently described Survivin 3B variant [45] or the 3G and 3G-variants discovered in our laboratory. However, one study shows that Survivin 3B interacts with chromosomal passenger proteins and suggests that it has an active nuclear export signal (NES), possibly indicating both cytoplasmic and nuclear distribution [29].

Role in Apoptosis

Survivin is a member of a family of caspase-specific inhibitors. It effectively inhibits the functions of caspases 3, 7 and 9, as well as the proapoptotic protein second mitochondria-derived activator of caspases/direct IAP binding protein with low pI (Smac/DIABLO) [46]. Caspase-9 is an initiator caspase and is activated in response to apoptotic stimuli derived from the intrinsic pathway of apoptosis, which is mediated via mitochondrial responses [47]. Mitochondria release cytochrome-c that recruits the apoptotic protease-activating factor-1 (Apaf-1), which in turn binds to, cleaves and activates caspase-9. Together these proteins form what is known as the “Apoptosome” [47-50] (Figure 3). The Apoptosome in turn leads to the cleavage of inactive procaspase-3 into its active form, which is known as an effector caspase [51]. Caspase-3 has a plethora of cleavage targets, including the protein inhibitor of caspase-activated deoxyribonuclease (iCAD), which sequesters CAD and upon its release translocates to the nucleus and degrades DNA [52]. Survivin deficiency exacerbates apoptosis in response to mitochondria-mediated apoptosis, also known as the intrinsic apoptosis pathway [53]. Survivin also binds to the mitochondria-derived proapoptotic protein Smac/DIABLO that binds to IAPs and acts to counterbalance anti-apoptotic proteins [20]. Studies have also shown that over-expression of Survivin protects cells against apoptosis induced through the extrinsic apoptotic pathway by agents that signal through death domain receptors such as Fas ligand (FasL) and tumor necrosis factor-alpha (TNF- α) [54, 55]. Another binding partner for Survivin is CRM1, which is a nuclear export receptor

Figure 3

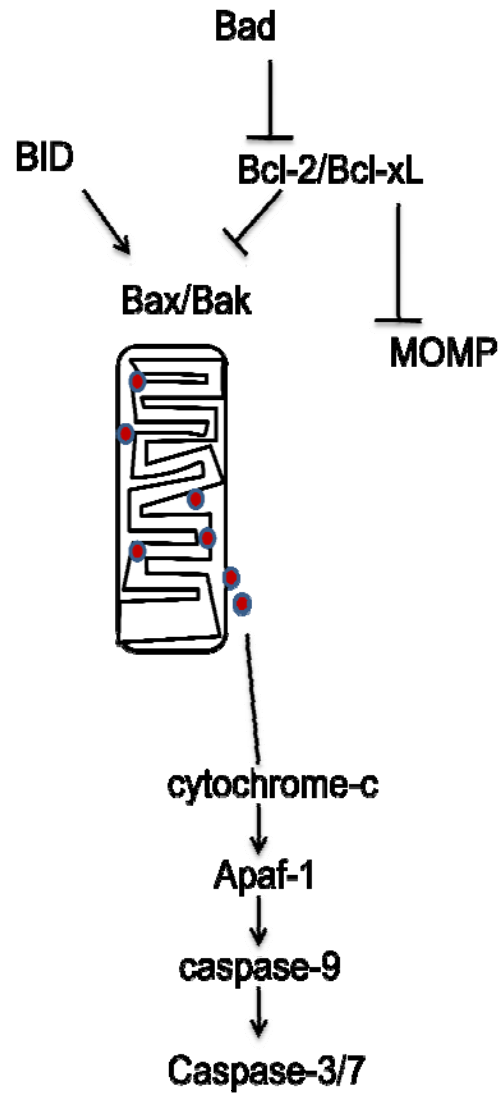

Adapted from Oberst, A. et al., 2008 [51]

Figure 3. The Apoptosome. The diagram represents proteins upstream as well as downstream of cytochrome-c release from the mitochondria. The Apoptosome progression is demonstrated here wherein proapoptotic internal stimuli activate proapoptotic factors such as Bad and BID in turn leading to the activation of proapoptotic Bax/Bak leading to mitochondrial outer membrane permeabilization (MOMP) and release of cytochrome-c. Pro-apoptotic activation of Bax/Bak can be counter-acted by anti-apoptotic factors such as Bcl-2/Bcl-xL, but these too can be inhibited by Bad. The released cytochrome-c binds the co-factor Apaf-1 and together they bind and activate procaspase-9 and form the functional Apoptosome. The Apoptosome subsequently cleaves effector procaspases-3 and -7 into their active forms ultimately leading to apoptosis.

that interacts with NES domains in shuttled proteins, and is necessary for nuclear export of Survivin into the cytoplasm that in turn is necessary for its anti-apoptotic function [21, 56, 57].

Role in Cell Cycle

It has been reported that in normal cells Survivin protein expression is up-regulated during progression to G₂/M phase of cell cycle and at anaphase Survivin is targeted for phosphorylation by the heterodimeric kinase p34Cdc2/Cyclin B1 at Threonine-34, an event considered to be important for both its cell cycle and anti-apoptotic functions [18]. This is further supported by evidence that a Threonine 34-to-Alanine non-phosphorylatable mutation produces a dominant-negative (dn) form of Survivin, which has a negative effect on cell cycle progression and apoptosis [58-62]. Survivin activates the Cdk2/Cyclin E complex leading to an increase in pRb phosphorylation contributing to cell cycle progression, as well as associates with Cdk4 leading to its nuclear translocation and accelerates cellular exit from S-phase and entry into G₂-phase [63].

During the transition between metaphase and anaphase, the chromosomal passenger complex (CPC) localizes to the microtubules at the central spindle. This complex is comprised of Aurora kinase B, INCENP, Survivin and Borealin and is important for chromosomal condensation, spindle assembly, microtubule-kinetochore interaction and chromosomal alignment, as well as the spindle checkpoint and completion of cytokinesis [64-66]. Borealin, also known as Dasra, binds to Survivin and directs

Survivin binding to INCENP rather than to Aurora kinase B [67, 68]. In the absence of Survivin cells undergo mitotic catastrophe (a type of cellular death) and cycling cells cannot properly complete mitosis. However, recently, *Yang et al.*, reported that cells could in fact complete cell cycle in the absence of Survivin, however, they suffered a great number of cell division abnormalities including aberrant chromosome segregation and incomplete cytokinesis, highlighting the necessity of Survivin in order to maintain normal cell cycling [69]. Although caspases-2 and -3 have been implicated, it is still unclear whether or not caspase activation is necessary for mitotic catastrophe to occur [70-72]. A role for these caspases could prove important because their activities are inhibited by Survivin and would further implicate Survivin in this process.

Role in Hematopoiesis

Survivin is expressed in normal hematopoietic cells and our laboratory has shown that it plays a physiological role in hematopoietic stem and progenitor cell function [3, 73, 74]. In hematopoietic cells, Survivin functions by regulating both cell cycle and caspase inhibition and is upregulated in response to hematopoietic cytokines such as thrombopoietin (Tpo), stem cell factor (SCF) and Flt3 ligand (FL), before entry into cell cycle [73]. Recently, a study in caspase-3 knockout mice showed dampened responses to specific cytokines and contribution to quiescence of hematopoietic stem cells [75], confirming that Survivin would act as a counter-balance, consistent with our laboratories finding that Survivin and active caspase-3 levels are found in inverse proportion in CD34⁺ human hematopoietic stem cells [3].

Target of Cancer Therapeutics

Survivin is found to be highly expressed in virtually all cancers with few exceptions [1, 76], and coupled with its limited expression in most adult tissues, has made Survivin an attractive cancer therapeutic target. Our laboratory has shown that dn-(T34A)-Survivin can abrogate the effects of constitutively active-H-Ras [62]. Studies using either the dn-T34A-Survivin alone [77] or a dual T34A/D53A mutated Survivin have shown efficacy on down-regulation of the anti-apoptotic effect of wt-Survivin on aberrant cells [77, 78]. In addition, the use of the human immunodeficiency virus (HIV) Tat protein that allows passage through the cell membrane, fused with the T34A-Survivin has been found to have a negative effect on the growth and survival of breast cancer and melanoma cells [79, 80]. Another method of targeting Survivin is the use of an adenoviral vector for combinatorial therapy. To this end, studies have shown that Adeno-T34A therapy in combination with the administration of the microtubule-affecting drug paclitaxel sensitizes prostate cancer cells to chemotherapy [81]. Furthermore, Adeno-T34A and Adeno-caspase-3 combinatorial treatment reduces Survivin expression in an ovarian carcinoma cell line [60].

It has been found that heat shock protein-90 (Hsp90) stabilizes Survivin, which means that disruption of Hsp90 activity in turn disrupts Survivin protein levels [12, 22]. Currently, drugs that bind to the ATP-binding pocket within Hsp90 with higher affinity than Hsp90's normal binding partners are being evaluated as therapeutic agents targeting

Survivin. In addition, Geldanamycin and its derivatives and AICAR are also being studied [82-87].

Hematopoiesis

Overview

Hematopoiesis is the lifelong process through which the cells of the blood and immune system are produced. These cells have an array of different functions, ranging from delivering oxygen to the body's tissues, preventing blood loss, to defending against pathogens. Hematopoietic stem cells are defined as cells with the ability to not only give rise to all the lineages of the blood but to have self-renewal capacity (Figure 4) [88].

Hematopoietic stem cells also produce multilineage progenitor cells that have the ability to give rise to cells in multiple but not all lineages and possess a limited self-renewal potential (such as the common myeloid progenitor cell or the common lymphoid progenitor cell), which in turn gives rise to more restricted progenitor cells that give rise to individual cell lineages and have no self-renewal potential [89].

Markers/Definitions

Currently the standard definition of a hematopoietic stem cell in humans, whether it is derived from umbilical cord blood (UCB) or bone marrow, is a cell possessing the cluster designation (CD) 34 and 90 markers but lacking CD38 and 45RA, termed $CD34^+CD38^-CD90^+CD45RA^-$ cells [88, 90-93]. These cells can be isolated using fluorescence activated cell sorting (FACS) using fluorochrome-conjugated antibodies. In mice, the definition of an HSC is a cell expressing Sca-1, c-Kit and SLAM (CD150)

Figure 4

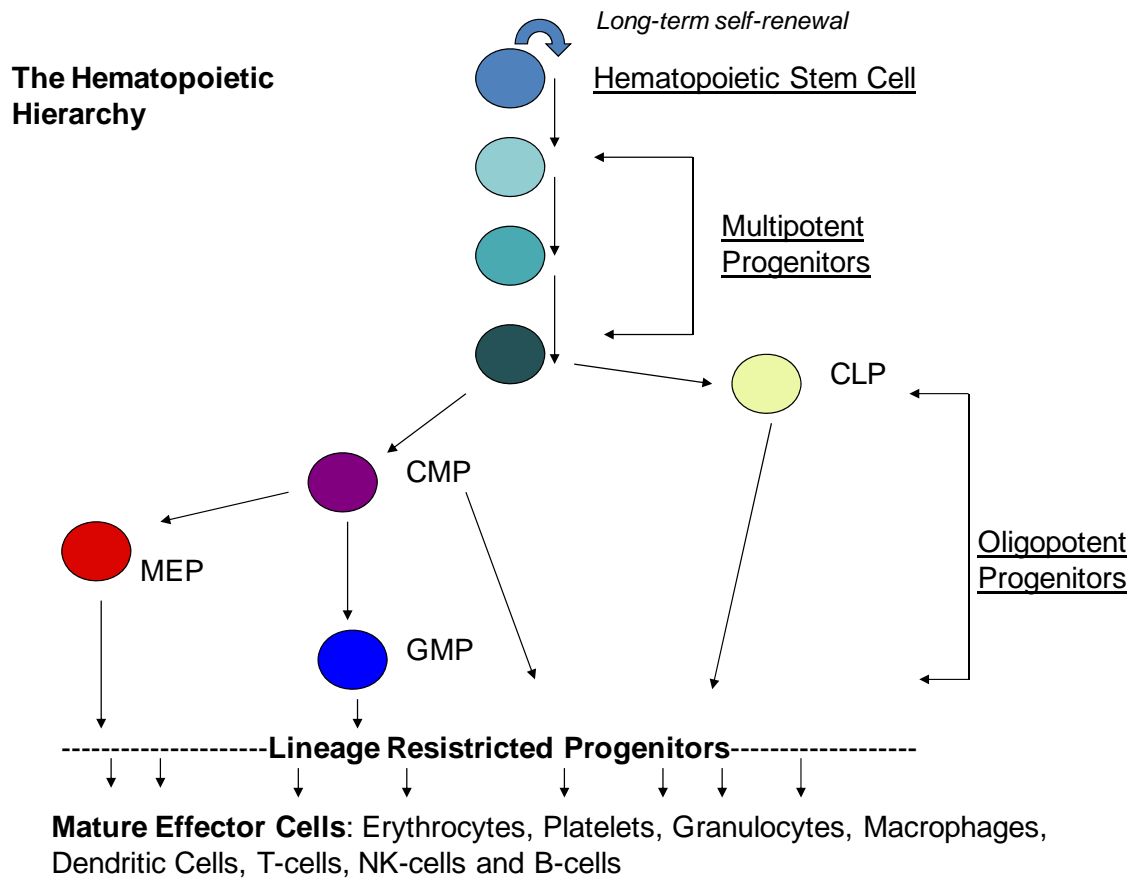

Adapted from Weissman, I.L. and Shizuru, J.A., 2008 [88]

Figure 4. The Hierarchy of Hematopoiesis. In the formation of the blood and its components, the hematopoietic stem cell first gives rise to multipotent progenitor cells as well as more stem cells (self renewal). The multipotent progenitor cells in turn give rise to lineage restricted (oligopotent) progenitor cells such as the common lymphoid progenitor (CLP), common myeloid progenitor (CMP), granulocyte macrophage progenitor (GMP) and megakaryocytic/erythroid progenitor (MEP). Through further differentiation and specialization, the oligopotent progenitor cells give rise to all the mature blood cell elements.

markers on their cell surface and lacking expression of CD48 and any markers defining lineage differentiation (Lin), e.g., T3, T4, T8, MAC1, Gr1, B220, Flk2 or CD34, or expressing Sca-1 and c-Kit and negative for CD34 and lineage markers. These cells are termed SLAM SKL or CD34⁻ SKL cells and contain the long-term repopulating HSC at a frequency of ~1 in 3 [94].

P34Cdc2/CDK1

Cyclin dependent kinase 1 (CDK1) or p34 Cell Division Cycle 2 gene (p34Cdc2) is a 34 kilodalton member of the normal cell cycle machinery. Cdc2 heterodimerizes with the 55 kilodalton protein cyclin B1, and together they form what is known as the mitosis promoting factor (MPF). MPF is activated at the end of G₂ phase (dephosphorylated at Thr14/Tyr15) by the phosphatase Cdc25c causing it to translocate to the nucleus where it helps usher cells from G₂ phase into Mitosis [95]. Figure 5 provides a schematic of p34Cdc2's activity in cell proliferation [96].

Role in Cell Cycle

P34Cdc2/Cyclin B1 is upregulated in late G₂ phase of the cell cycle and peaks at metaphase and is involved in centrosome separation, which is required for bipolar spindle assembly via phosphorylation of motor proteins [97]. It also targets lamina for phosphorylation aiding in nuclear structure destabilization that leads to a breakdown of the nuclear envelope [98]. P34Cdc2/Cyclin B1 also contributes to chromosome condensation through condensin phosphorylation [99] and is auto-regulated by helping to

Figure 5

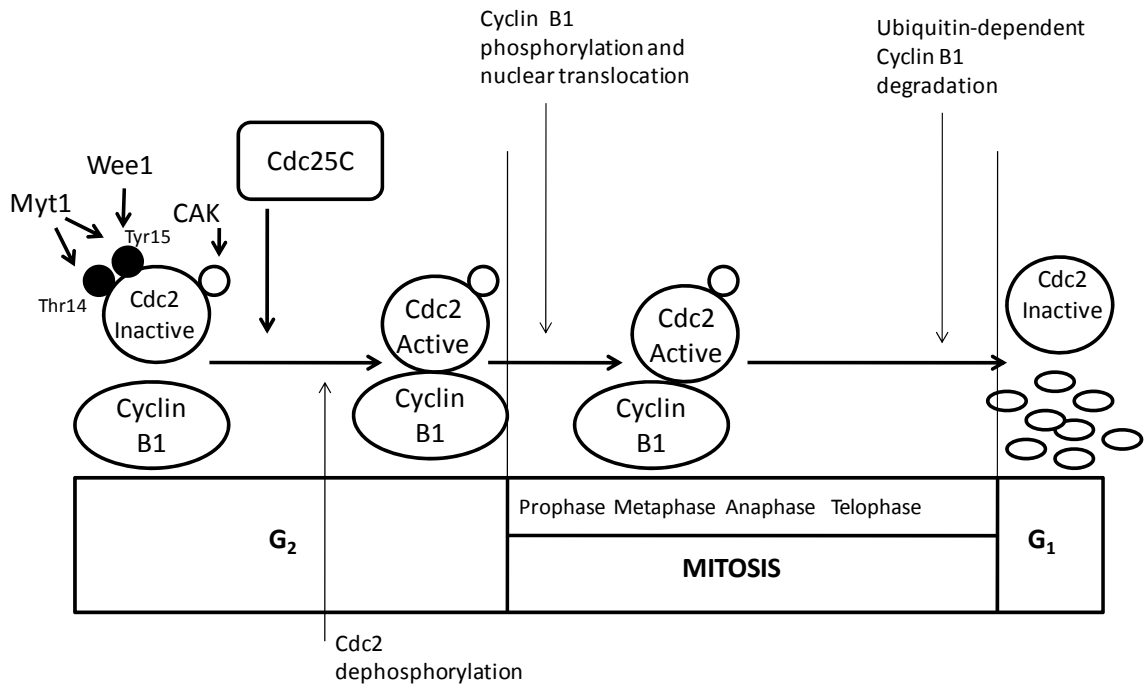

Adapted from Castedo, M. et al., 2002 [96]

Figure 5. Cdc2 and Cell Cycle. This figure summarizes the accepted role of Cdc2 in the cell cycle during normal mitosis. During most of the cell cycle Cdc2 is kept in an inactive state by phosphorylation at its Threonine-34 and Tyrosine-15 residues by the kinases Wee1 and Myt1. During progression from the G₂ phase into mitosis, the phosphatase Cdc25c dephosphorylates these residues and cyclin activating kinase (CAK) phosphorylates Cdc2 Threonine-161 resulting in an active Cdc2 that binds Cyclin B1 to form a heterodimeric kinase. Once active Cdc2/Cyclin B1 translocates to the nucleus where among other targets, it phosphorylates Survivin at Threonine-34 during anaphase. Afterward, Cyclin B1 is then targeted for degradation and Cdc2 is once again rendered inactive.

activate the anaphase promoting complex (APC) before cells enter anaphase, which in turn targets proteins for degradation including Cyclin B1 [100-103].

Role in Apoptosis

There is considerable evidence that improper activation of Cdc2 is involved in activation of apoptosis. Active Cdc2 can cause aberrant entry into mitosis, which causes premature chromatin condensation and apoptosis [104-107] and inhibition of Cdc2 with a dominant-negative mutant can protect cells from apoptosis or mitotic catastrophe induced by Chk2 inhibition [70, 108]. However, studies with Cdc2 deficient cells showed that they could still undergo apoptosis, while other studies have shown that Cdc2 activation/inactivation levels do not change when these cells undergo apoptosis.

Although its exact role is still not completely understood, it is clear that Cdc2 does in fact have a role during certain instances of apoptosis, and likely in a cell-specific manner [109-111]. The current paradigm for Cdc2's involvement in apoptosis are outlined in Figure 6.

Cell Cycle

Overview

Cell Cycle is the process that cells undergo to divide and produce two genetically identical daughter cells. It begins with a cell within a quiescent state G_0 - or in stasis G_1 -Phase. Upon receiving intrinsic or extrinsic mitogenic signals, the cell is activated and initiates its progression into S-Phase wherein the cell duplicates its genome, followed by the G_2 -Phase where the cell produces most of its protein repertoire (Figure 7a). The G_0 to

Figure 6

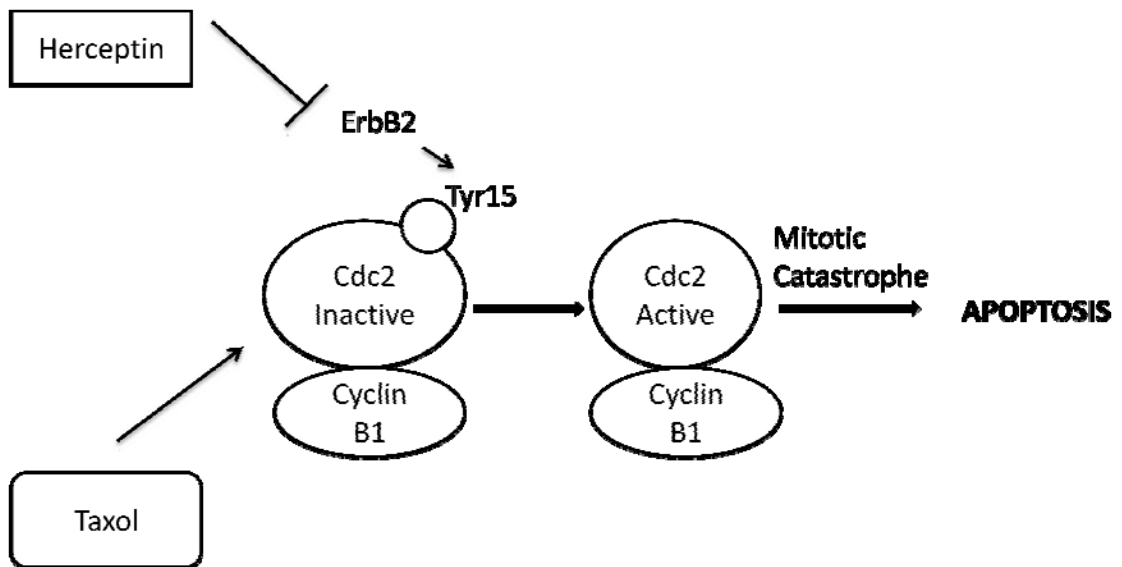

Adapted from Castedo, M. et al., 2002 [96]

Figure 6. Cdc2 and Apoptosis. Improper activation of Cdc2 can lead to mitotic catastrophe. In ErbB2-expressing cells, ErbB2 targets Cdc2 Tyrosine-15 for phosphorylation to help keep it properly inactive. However, the use of the ErbB2-inhibiting drug Herceptin or microtubule destabilizing drug Taxol result in improper Cdc2 activation and ultimately mitotic catastrophe.

Figure 7

A.

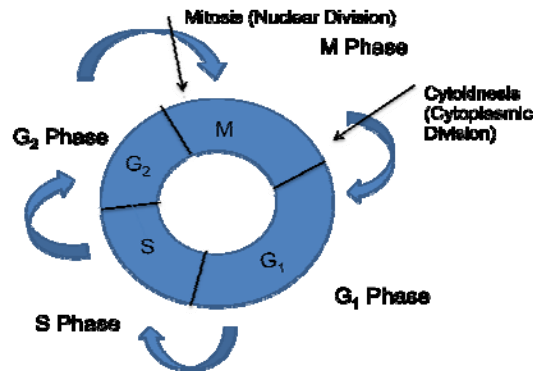

B.

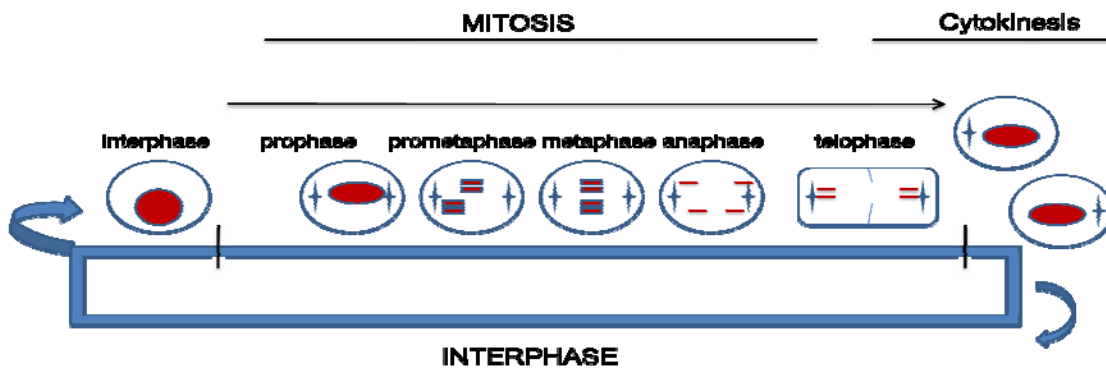

C.

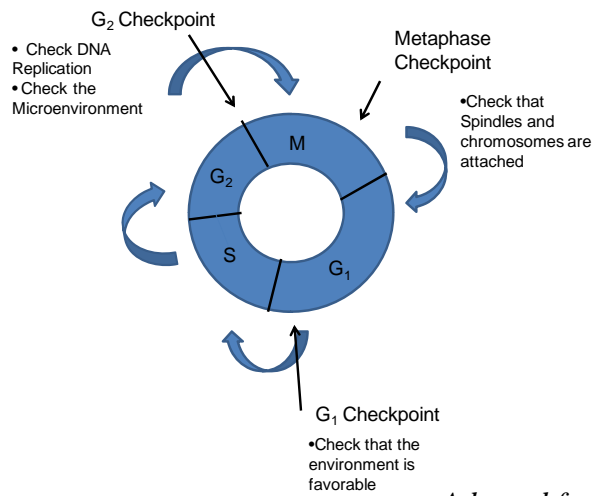

Adapted from Mol Biol of the Cell [113]

Figure 7. Cell Cycle. A) Cell cycle overview. Cell cycle is separation into four major phases: G_1 , S, G_2 and M. B) Mitosis overview. M-phase can be divided into five sub-phases: Prophase (formation of the mitotic spindles, chromatin condensation), Prometaphase, Metaphase (alignment of the chromosomes), Anaphase (attachment of the chromosomes to the mitotic spindles and separation) and Telophase (formation of the cleavage furrow) ultimately to cytokinesis, the formation of two daughter cells. C) Cell cycle checkpoints. Cells have cell cycle checkpoints in place to ensure faithful replication of cells and avoid aberrant growths. If cells do not pass the cell cycle checkpoint their progression is halted or apoptosis can occur. The first checkpoint exists between G_1 phase and S phase to ensure the microenvironment is conducive for cell cycle progression. The second checkpoint exists before entry into mitosis to ensure faithful DNA replication and again a conducive microenvironment for progression to occur. Lastly, before completion of mitosis, a checkpoint exists to ensure proper attachment of the mitotic spindles and chromosomes.

G₂ phase of the cell cycle is known as Interphase. Thereafter, cells enter their mitotic phase, which is divided into prophase, prometaphase, metaphase, anaphase and telophase (Figure 7b). Following proper cytokinesis, two daughter cells are formed.

Cell Cycle Arrest and Cell Cycle Checkpoints

In order for cell cycle to progress correctly, there are a number of checks and balances set in place in order to ensure proper division and replication; known as cell cycle checkpoints (Figure 7c). The G₁ checkpoint is set-up to ensure that cells are genomically stable and healthy before entering S-phase where DNA is replicated. The “master regulator” of the G₁ checkpoint is the p53 tumor suppressor protein [112]. The G₂ checkpoint protects cells from potentially detrimental replication following DNA damage and is governed by the Chk1, Wee1 and Myt1 kinases [114]. It is at G₂, after activation of Wee1, that the p34Cdc2/Cyclin MPF ushers cells into mitosis. The spindle checkpoint in metaphase functions to ensure that the cells have properly aligned their chromosomes and that the machinery is adequately prepared to separate the chromosomes and complete cytokinesis, otherwise mitotic catastrophe occurs [115].

Apoptosis

Overview

Apoptosis, or programmed cell death, is a cellular process that ensures that aberrant, unwanted or unnecessary cells are properly disposed of (e.g., cancer cells, excess T cells after clearance of infection and cells during embryonic development). The

central executor of this process is the caspase cascade. There are two pathways that activate the caspase cascade: the intrinsic and extrinsic apoptotic pathways.

Intrinsic Pathway

The intrinsic pathway of apoptosis is designed to sense internal signals derived from irreparable damage caused within the cell. Components of the intrinsic apoptotic pathway include Smac/DIABLO, Bad, Apaf-1, cytochrome-c, caspase-9, caspase-3 and proapoptotic bcl-2 family members [116]. Internal signals generated by DNA damage, cytotoxic drugs or improper cell cycle, compromise mitochondrial membrane potential resulting in release of proapoptotic factors such as cytochrome-c and Smac/DIABLO. Cytochrome-c binds to Apaf-1, which in turn binds with and activates caspase-9 forming the Apoptosome that with the co-factor dATP results in the activation of effector caspases-3 and -7 and ultimately cell death (Figure 8).

Extrinsic Pathway

The extrinsic pathway of apoptosis is designed to sense external signals from the microenvironment that can indicate that a cell's viability is no longer necessary. Components of the extrinsic apoptotic pathway are mostly ligands and receptors of the TNF superfamily of receptors that possess death domains in their intracellular portion. For TNF receptors, these are termed tumor necrosis factor receptor-associated death domains (TRADD) and for Fas receptor, they are termed fas receptor-associated death domains (FADD). In the extrinsic pathway, external factors such as TNF-related apoptosis inducing ligand (TRAIL), Fas ligand or high levels of tumor necrosis factor- α

Figure 8

A.

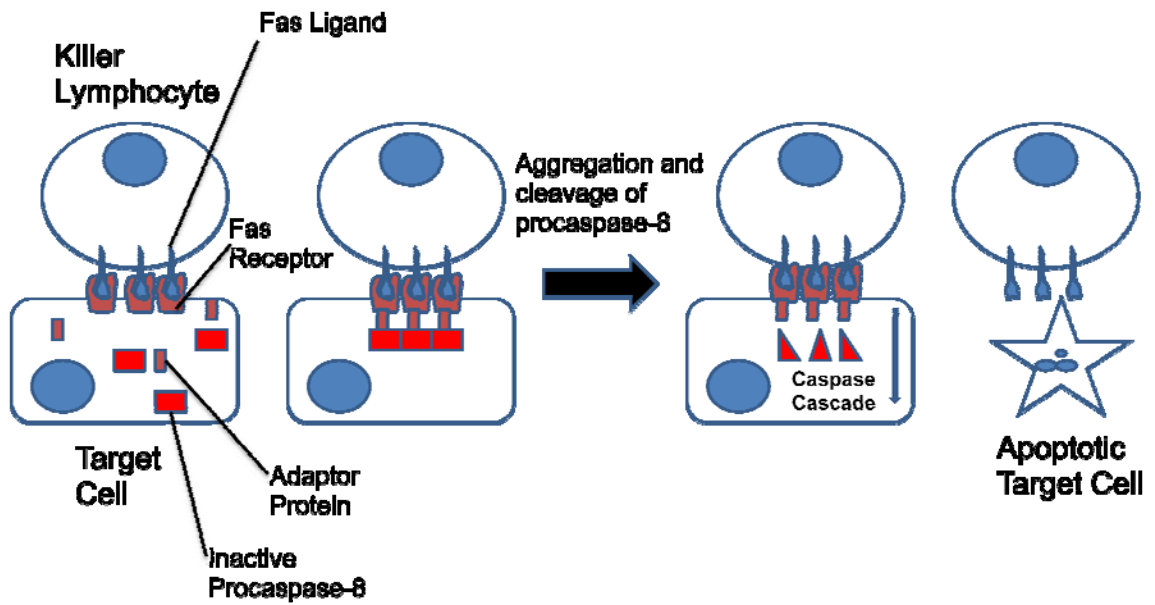

B.

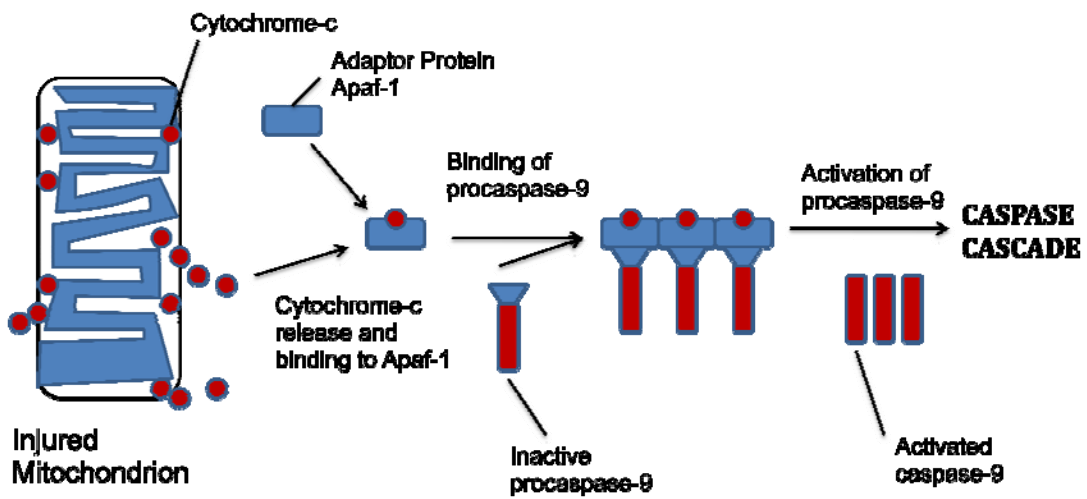

Adapted from Mol Biol of the Cell [113]

Figure 8. Intrinsic and Extrinsic Apoptotic Pathways of Apoptosis. A) Extrinsic apoptosis occurs when external signals (such as Fas ligand on the surface of a killer lymphocyte) bind to Fas receptors on another cell leading to their aggregation, activation and formation of the death inducing signaling cascade (DISC), which itself activates the caspase cascade leading to apoptosis. B) Intrinsic apoptosis occurs when signals within the cell indicate that an uncorrectable aberration has occurred (such as irreparable DNA damage), leading to compromising of the mitochondrial membrane potential releasing cytochrome-c and leading to formation of the Apoptosome, activation of the caspase cascade and ultimately apoptosis.

result in aggregation of tyrosine kinase receptors of the TNF Superfamily of receptors such as FasR [116]. Subsequently their intracellular death domains bind, along with procaspase-8, to form the Death Inducing Signaling Complex (DISC). DISC is responsible for the cleavage of initiating procaspase 8 into its active form and in turn caspase-8 activates the effector caspases-3 and -7 (Figure 8).

Caspases-3, -7 and -9

Cell death (CED) proteins are the central machinery of apoptosis that were first discovered in *C. elegans* [117, 118]. The mammalian homologs have been identified [49, 119-121] and include the cysteinyl aspartate proteinases or caspase family. Caspases can be categorized into two groups: initiator caspases and effector caspases [122].

Initiator caspases have longer prodomains (compared to effector caspases) as well as caspase recruitment domains (CARD) or death effector domains (DED) (Figure 9) and function by interacting with upstream signaling proteins. Caspase-9 forms part of the apoptosome and interacts with Apaf-1 through CARD-CARD domain interactions [123]. Caspase-9 is also a substrate of both Akt and Erk (extracellular signal regulated kinase)/MAPK (mitogen activated protein kinase), which phosphorylate caspase-9 at Serine-196 and Threonine-125, respectively [124, 125] and inhibit its proapoptotic activity. During mitosis, the Cdk1/Cyclin B1 complex can also phosphorylate caspase-9 at Threonine-125 and inhibit its activity [126].

Effector caspases are categorized by short prodomains and are normally cleaved by initiator caspases. They also exist as homodimers in their procaspase form. Caspases

Figure 9

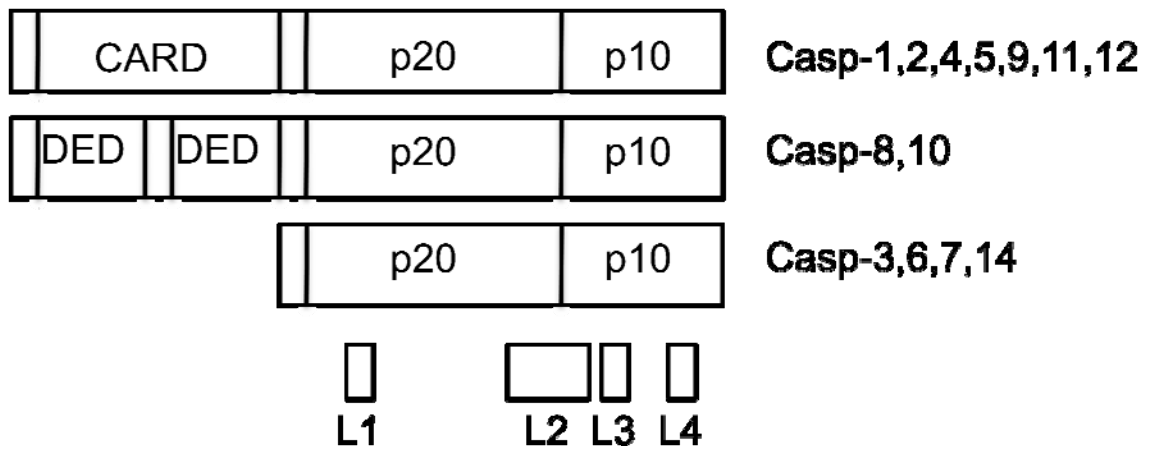

Adapted from Li, J. and Yuan, J., 2008 [122]

Figure 9. Caspase Structures and Domains. This figure shows the domains present in the caspase family of proteinases such as the p10 and p20 subunits. L1-L4 represent the catalytic center loops. CARD (caspase recruitment domain) domains are necessary for protein-protein interaction with other CARD-containing proteins, and DED (death effector domain) domains are required for interaction with upstream signaling components of the apoptotic pathway.

3 and 7 are effector caspases. They are quintessential in executing apoptosis, which is illustrated in caspase-3/caspase-7 double-knockout mice that not only show a marked apoptotic deficiency, immediate postbirth mortality and exencephaly, but their derived mouse embryo fibroblasts (MEF) also exhibit strong resistance to both intrinsic and extrinsic apoptosis [127].

Wee1 Kinase

Structure, Function and Role in Cell Cycle

Wee1 is a member of the Wee1 family of kinases that includes Myt1 and Wee1 that help to coordinate the cell cycle machinery. Its main known function is the inactivation of the Cdc2/Cyclin B1 complex during mitosis by phosphorylation of Cdc2 on Tyrosine-15. Wee1 is approximately 90 kiloDaltons in size and together with Chk1 and Myt1 regulates the G₂ checkpoint [114]. It also regulates Cdc2 activity through subcellular localization, i.e., the two cannot both exist in their active states within the same subcellular compartment [128]. It has been shown that lack of Wee1 kinase results in early entry into mitosis before the deficient cells have had sufficient time to grow, resulting in smaller daughter cells [129].

Role in Apoptosis

Over-expression of Wee1 in umbilical cord blood (UCB) CD34⁺ hematopoietic cells has been reported to provide a protective effect from cytotoxic chemotherapeutic agents [130]. Similarly, ectopic Wee1 protects BHK cells from apoptosis induced with granzyme B [131]. Conversely, down-regulation of Wee1 by RNA interference

sensitized HeLa cells to apoptosis [114] and was seen to have a similar effect in HIV-1 VPR-induced apoptosis [132], underlining its cytoprotective role. Interestingly, it has been suggested that cytoplasmic localization of Wee1 is required to promote survival, whereas nuclear localization promotes apoptosis [133].

Purpose of This Study

The role of Survivin in hematopoiesis is a focus of our laboratory. We have shown that Survivin has a role in regulating hematopoietic stem cell maintenance and survival and is required for hematopoietic stem and progenitor cell (HSPC) cell cycle entry [3, 73, 134]. It is becoming clear that Survivin's antiapoptotic function is conducted mainly through its inhibition of proapoptotic proteins such as Smac/DIABLO and caspases-3, -7 and -9. Over-expression of Survivin results in increased p34Cdc2 phospho-Tyrosine-15 levels. While it is known that p34Cdc2/Cyclin B1 targets Survivin for phosphorylation, Survivin does not contain intrinsic kinase activity thus the mechanism by which Survivin over-expression results in an increase in p34Cdc2-Tyrosine-15 phosphorylation is unclear. Understanding the role of Survivin has significant implications on the biology of stem cells and cancer biology overall. The focus of this work was to elucidate the mechanism of action through which Survivin regulates p34Cdc2. Using the BaF3 mouse hematopoietic cell model we have identified that Survivin protects the Wee1 kinase from caspase-3 dependent degradation that in turn maintains inactivating Cdc2 phospho-Tyrosine-15 levels, resulting in a block in apoptosis and enhanced overall cell survival and proliferation.

MATERIALS AND METHODS

Cell lines

The IL-3 dependent murine BaF3 cell line was used as a model for normal growth factor-dependent hematopoietic cells. BaF3 cells were cultured in RPMI-1640 (Lonza Inc., Allendale, NJ) supplemented with 10% heat-inactivated fetal bovine serum (HI-FBS) (HyClone Sterile Systems, Logan, UT) and 100 pg/mL of recombinant murine IL-3 as well as 100 units/mL of Penicillin/Streptomycin (Lonza Inc.) in T75 tissue culture flasks. BaF3 cells were permanently transduced with wild-type (wt) or dominant-negative (dn) Threonine-34-to-Alanine mutation (T34A) mouse Survivin constructs in the bicistronic MIEG3(-) eGFP containing vector as previously described [61]. GFP positive cells were FACS-sorted gating on the highest luminescence-emitting cells (high eGFP expression correlates directly with Survivin expression) and transduced cells maintained as cell lines. The wt- and ITD-Flt3 BaF3 cell lines were provided by Dr. DG Gilliland, Harvard Medical School, Boston, MA. The ITD-Flt3 BaF3 cells were maintained in culture using the same conditions described above.

The human MCF-7 breast cancer epithelial cell line was cultured in α MEM media supplemented with 10% HI-FBS, 100 units/mL of Penicillin/Streptomycin and 2.5 mL of L-Glutamine per 500 mL of media in 10 cm tissue culture dishes. These cells lack caspase-3 protein due to a 47-bp deletion in the corresponding gene [135]. Human Jurkat T-cells were cultured in RPMI-1640 media supplemented with 10% HI-FBS and

0.1% sterile 2-Mercaptoethanol (Bio-Rad Laboratories, Hercules, CA) in T75 tissue culture flasks.

Transductions

Briefly, for retroviral transductions, purified MIEG-IRES-EGFP plasmid alone or containing wt-Survivin or dn-Survivin were transfected into Phoenix Eco cells using Lipofectamine 2000 (Invitrogen, Carlsbad, CA). After sequential infection of normal BaF3 cells, GFP⁺ (infected) cells were sorted and isolated by FACS and cultured using the conditions described above for BaF3 cells.

Antibodies and Reagents

The caspase inhibitors Ac-DEVD-CHO, Ac-LEHD-CHO and Z-VAD-FMK and the Hsp90 inhibitor AICAR were purchased from BioMol International (Plymouth Meeting, PA). The anti-Wee1, anti-p34Cdc2 and anti-Actin antibodies were purchased from Santa Cruz Biotechnology (La Jolla, CA). Anti-p34Cdc2 phospho-Tyrosine-15, anti-p34Cdc2 and anti-PARP antibodies were from Cell Signaling (Boston, MA). Anti-Survivin antibody (Clone AF886) was from R&D Systems (Minneapolis, MN). Annexin-V-PE and 7-AAD were purchased from BD Pharmingen (San Jose, CA).

Cell Lysis and Immunoblotting

Cell lysates were prepared using, Triton-X lysis buffer (50 mM HEPES, pH 7.0, 150 mM NaCl, 10% Glycerol, 1.2% Triton X-100, 1 mM EGTA, 1 mM EDTA, 10 mM sodium pyrophosphate, 100 mM NaF, 1mM phenylmethylsulfonyl fluoride, 1 mM sodium orthovanadate) or Urea-SDS lysis buffer (62.5 mM Tris (pH 6.8), 6 M urea, 10%

glycerol, 2% SDS, 0.003% bromophenol blue, and 5% 2-mercaptoethanol) [136], supplemented with Complete Mini protease inhibitor cocktail (Roche Diagnostics Inc., Indianapolis, IN). The protein content in cell lysates was determined using a Bradford assay (Bio-Rad Laboratories). Lysates were heated at 100 °C for 5 minutes then run on 8% or 15% SDS-PAGE gels and transferred to PVDF membranes (Millipore, Billerica, MA) at 110 milliamps for 2 hours. The membranes were blocked with 5% milk solution for 1 hour then probed for various proteins. Stripping and reprobing was performed using RestoreTM western blot stripping reagent (Pierce Biotechnology, Rockford, IL). Measurement of western blot OD readings were performed using Adobe Photoshop. Individual blots were quantitated using the histogram application to obtain mean values. Experimental means were standardized to loading controls and final values were standardized to either vector or 0 hours which were given the value of 1.

Immunoprecipitation

Human Jurkat cells were harvested in log-phase growth and total cell lysates prepared as described above. Two and one-half mg of lysate for each of three immunoprecipitations, normal rabbit IgG, Survivin and Wee1, were pre-cleared using 20 uL per sample of protein agarose A/G beads (Santa Cruz Biotechnology) for 15 minutes with rocking at 4 °C and pre-cleared lysates transferred to new tubes containing 2.5 ug of the same antibodies used for immunoprecipitation. Lysates were incubated for one hour and 50 uL of protein agarose A/G beads added to each sample and incubated overnight with rocking at 4 °C. Immunoprecipitates were subsequently washed three times using

Triton-X lysis buffer and 35 μ L of SDS-PAGE loading buffer added to immunoprecipitated samples. SDS-PAGE loading buffer (6X) was added to 100 microgram samples of total cell lysates. Immunoprecipitates and total cell lysates were heated at 100 °C for 5 minutes and run on SDS-PAGE gels.

Treatments

Log-phase growing BaF3 cells were counted, washed and resuspended in serum-free RPMI-1640 and plated in 6-well tissue culture plates at a concentration of 1×10^6 cells per mL in 4 mL of media two-hours prior to treatment. Caspase inhibitors were prepared as 1000X stock solutions in DMSO (Ac-DEVD-CHO and Ac-LEHD-CHO at 25 mM and Z-VAD-FMK at 20 mM). Control groups received DMSO alone. Cells were treated for 2 hours at 37 °C, harvested and lysates prepared. For analysis of the effects of Hsp90 inhibition, AICAR was prepared in DMSO and used at 25 μ M. Cells receiving AICAR or DMSO were harvested at various time points, lysates prepared using Triton-X lysis buffer and samples run on SDS-PAGE. In order to measure apoptosis, BaF3 cells were either plated at 1×10^5 cells/mL in 4 mL of normal growth media or RPMI with 1% FBS without IL-3 for 0, 24 or 48 hours, cell pellets collected and apoptosis quantitated using Annexin V/7AAD and flow cytometry. Adherent MCF7 cells were treated with caspase inhibitors in similar fashion to BaF3 cells. MCF7 cells were trypsinized (Trypsin, Lonza) for 5 minutes, washed, counted and plated at 2.5×10^5 cells per mL in 10 mL of media in 10 cm tissue culture plates for 24 hours prior to treatment to allow

readherence to the plate. At 24 hours post-plating, cells were treated and then harvested and lysates prepared.

Flow Cytometry

In order to quantitate apoptosis, cells were washed and resuspended in Annexin-V binding buffer and Annexin-V and 7-AAD (BD Pharmingen) added to individual samples. Annexin-V single-positive, 7-AAD single-positive, Annexin-V/7-AAD double-positive as well as double-negative populations were quantitated in triplicate samples by FACS using BD software CellQuest.

Statistics

GraphPad t-test calculator, available online at <http://www.graphpad.com/quickcalcs/ttest1.cfm> was used to perform statistical analyses. Individual readings were entered into the calculator and mean and SEM values obtained, statistical significance was determined as a p value less than 0.05.

RESULTS

Chapter 1

Survivin Maintains Phosphorylation of p34Cdc2 at Tyrosine-15

Over-Expression of Survivin Correlates with Survival and Elevated Phospho-Tyr15-Cdc2 Levels

Growth factor withdrawal induces apoptosis of BaF3 cells over 48 hours post-withdrawal measured by Annexin V and 7AAD staining (Figure 10). Ectopic expression of wt-Survivin protected cells from apoptosis at 24 and 48 hours. In contrast, in cells over-expressing the dominant-negative (dn) T34A-Survivin, increased apoptosis was observed. In addition, viable cell counts performed using trypan blue exclusion demonstrated that wt-Survivin over-expression increased the total number of viable cells compared to MIEG and T34A-Survivin-transduced cells (Figure 11). As an additional measurement of apoptosis, we quantitated intracellular caspase-3 activity by intracellular flow cytometry. Using anti-active (cleaved) caspase-3 antibody we observed a higher level of caspase-3 activity in MIEG and T34A-transduced BaF3 cells than in cells over-expressing wt-Survivin (Figure 12), consistent with Survivin's ability to abrogate caspase-3 activity [54].

An additional and interesting observation was made when these cells were analyzed further using western blots. Cells expressing ectopic wt-Survivin contained significantly higher levels of Tyrosine-15 phosphorylated p34Cdc2 (an inhibitory

Figure 10

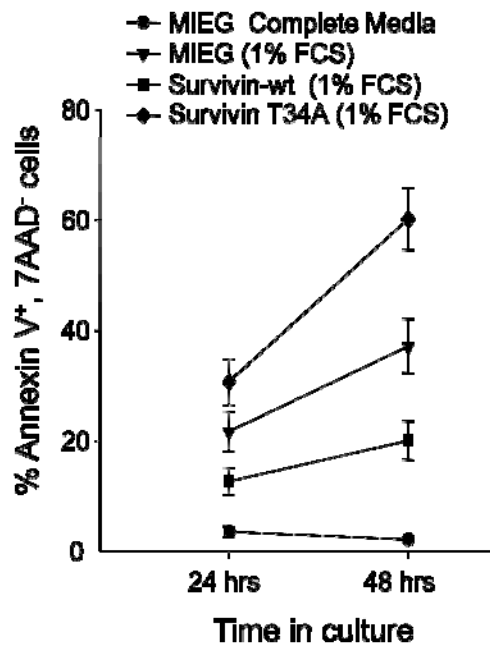

Figure 10. Early Apoptotic Index of the BaF3-Transduced Cell Lines. MIEG, wt-Survivin and dn-T34A-Survivin transduced BaF3 cells were washed, counted and 2.5×10^5 cultured in RPMI media with 1% HI-FBS without IL-3 for 24 or 48 hrs in triplicate in 6-well tissue culture plates. At 24 and 48 hours after culture initiation, cells were harvest, washed and stained with Annexin-V and 7AAD (as described in materials and methods) and apoptosis quantitated by FACS analysis. Data is expressed as mean % Annexin V⁺ 7AAD⁻ cells \pm S.E.M. for n=3 experiments, p = <0.05

Figure 11

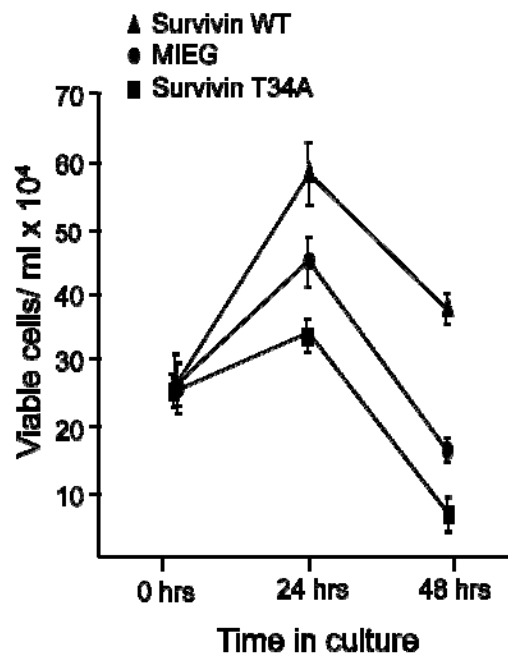

Figure 11. Viable Cell Counts of the BaF3 Cell Lines. MIEG, wt-Survivin and dn-T34A-Survivin transduced BaF3 cells were washed, counted and 2.5×10^5 cells cultured in pro-apoptotic media (cytokine-deficient, 1% HI-FBS) for 24 and 48 hours in triplicate in 6-well tissue culture plates. The total viable BaF3 cell number was quantitated microscopically at 24 and 48 hours of culture based on trypan blue dye exclusion. Data are expressed as mean \pm SEM from 3 experiments, $p = <0.05$

Figure 12

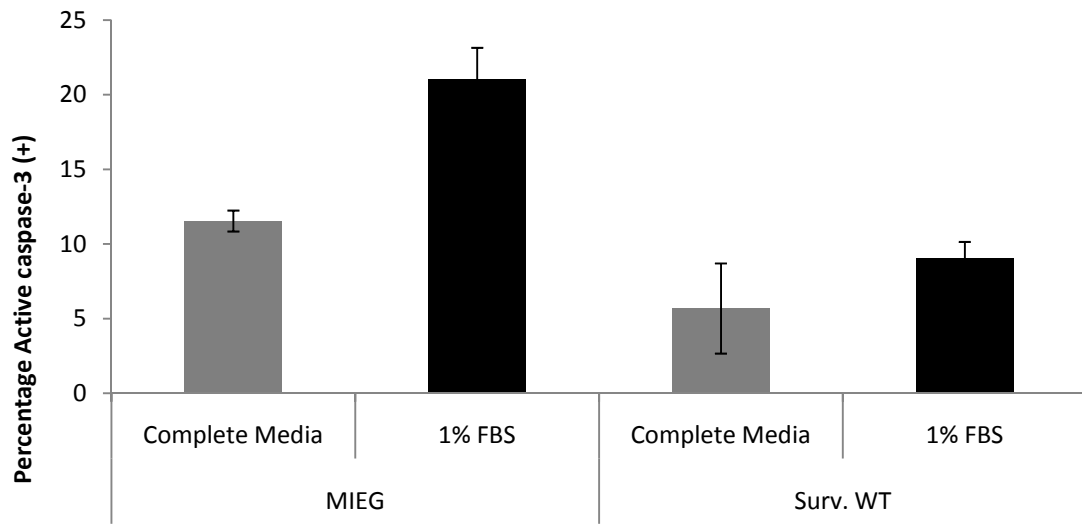

Figure 12. Active Caspase-3 Assay. MIEG and wt-Survivin transduced BaF3 cells were washed, counted and 2.5×10^5 cells cultured in 1% FBS/No-IL3 RPMI media for 24 hours in triplicate in 6-well tissue culture plates. Cells were fixed with 1% paraformaldehyde solution, their membranes permeabilized with 0.25% Triton-X/0.5% bovine serum albumin/phosphate-buffered saline and intracellular staining performed with anti-active caspase-3 (p17) antibody, then apoptosis quantitated by FACS analysis of p17 expression. Blot is representative of 2 experiments and expressed as mean \pm SEM.

Figure 13

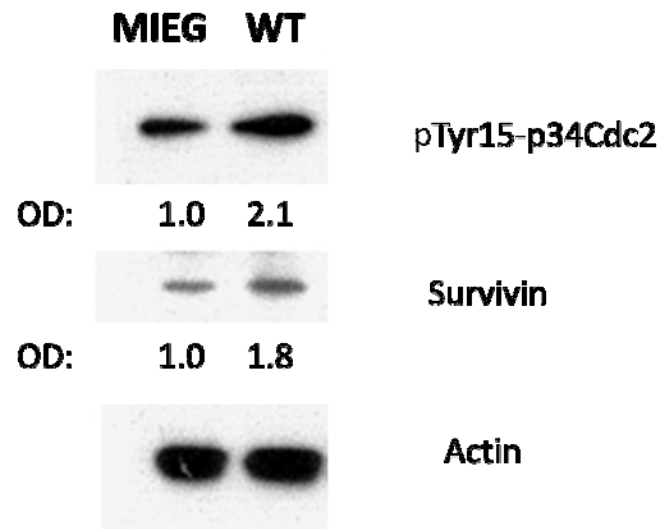

Figure 13. Protein Profile of the BaF3 Cells Lines. Immunoblotting analysis was performed for phospho-Tyrosine15 p34Cdc2, Survivin and Actin on lysates from exponentially growing BaF3 cells transduced with either MIEG vector or wt-Survivin. One hundred micrograms of total cell lysates were run on 8-15% gradient SDS-PAGE gels. Relative protein concentration relative to loading control is shown below bands. Blot is representative of 3 experiments.

phosphorylation) compared to MIEG and T34A-transduced cells (Figure 13). We have consistently seen that BaF3 cells expressing ectopic wt-Survivin have ~2-fold higher levels of Tyrosine-15 phosphorylated p34Cdc2, consistent with reports by others that indicate that Cdc2 activation is required for apoptosis [131, 137-140] and that Survivin decreases apoptosis. In BaF3 cells in which Survivin is disrupted by expression of dn-T34A-Survivin, phospho-Tyrosine15 Cdc2 levels are ~4-fold lower than in cells expressing ectopic wt-Survivin.

In order to study the effect of Survivin upregulation on Tyrosine-15 Cdc2 phosphorylation in the context of acute leukemia [141], we utilized BaF3 cells that were permanently transduced with either wild-type (wt) Flt3 or internal tandem duplication (ITD) mutants of the Flt3 receptor derived from patients with acute myeloid leukemia (AML) [142]. In ITD-Flt3 BaF3 cells Survivin up-regulation is derived from the mitogenic signals induced by the constitutively active mutant Flt3 receptors, not from the introduction of ectopic Survivin and provides a model in which Survivin is up-regulated in a manner similar to primary cancers *in vivo*. In these cells we observed significant upregulation of Survivin and elevated Cdc2-Tyr15 phosphorylation levels (Figure 14). Although at first glance phospho-Tyr15-Cdc2 levels appear lower in BaF3 cells expressing the N51 mutant, standardization to total Cdc2 (using densitometry) indicates that there is also a decrease in total Cdc2. Therefore the levels of Cdc2-Tyr15 phosphorylation levels are comparatively higher than wt-control. This effect is further accentuated in cells that have been placed in proapoptotic conditions (cytokine-deficient,

Figure 14

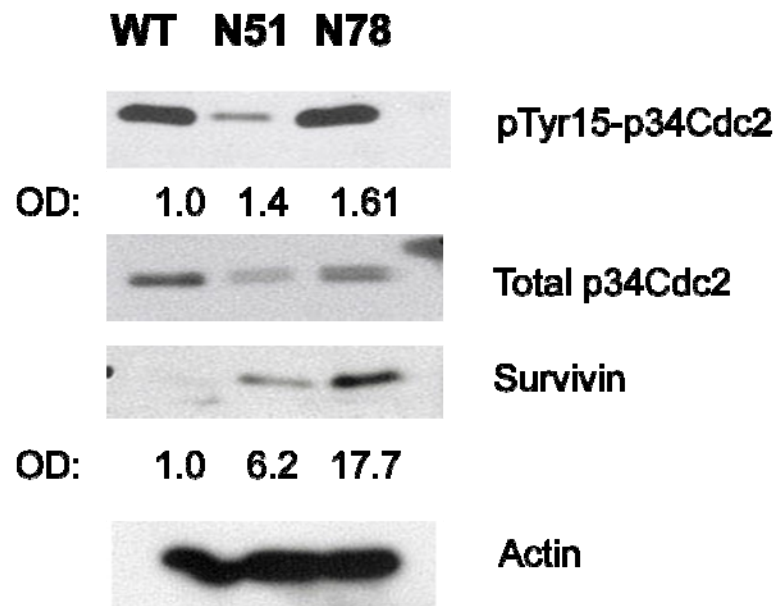
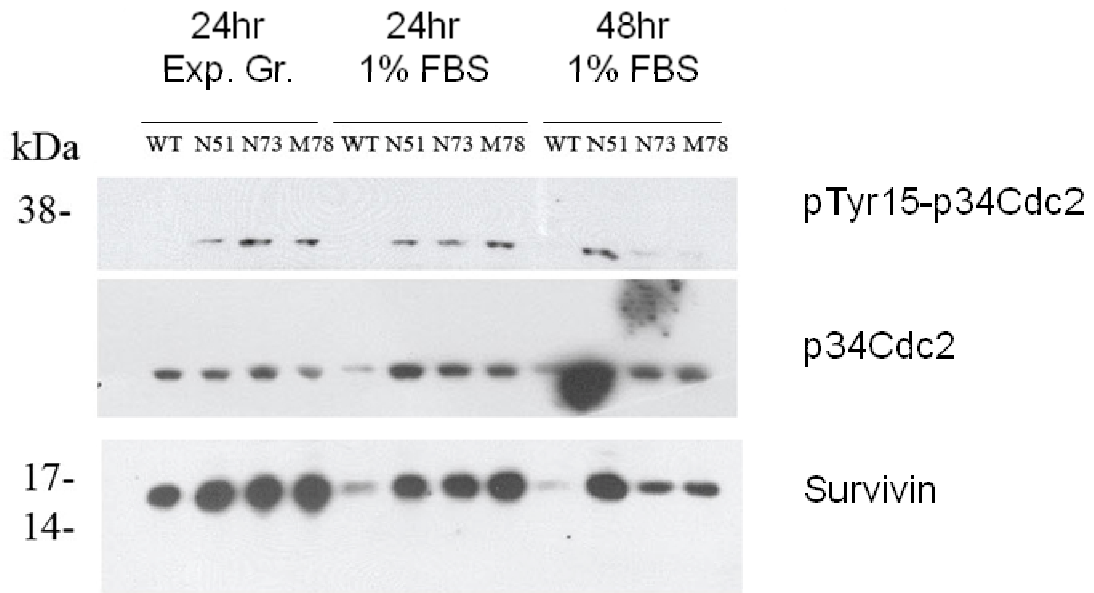

Figure 14. Cdc2-Tyr15 Phosphorylation is Elevated in BaF3 Cells Expressing ITD-Flt3 Mutants. BaF3 cells transduced with either wt-Flt3 or ITD-Flt3 mutations 51 or 78 were harvested, lysates prepared, 100 ug of each sample run on SDS-PAGE gels and analyzed via immunoblotting for Cdc2-Tyr15 phosphorylation (pY15 Cdc2), total Cdc2, Survin and Actin. Blots were quantitated using densitometric analysis, standardizing to wt-control (1.0), phospho-Cdc2 was standardized to total Cdc2, and Survivin to β -actin.

Figure 15

A.



B.

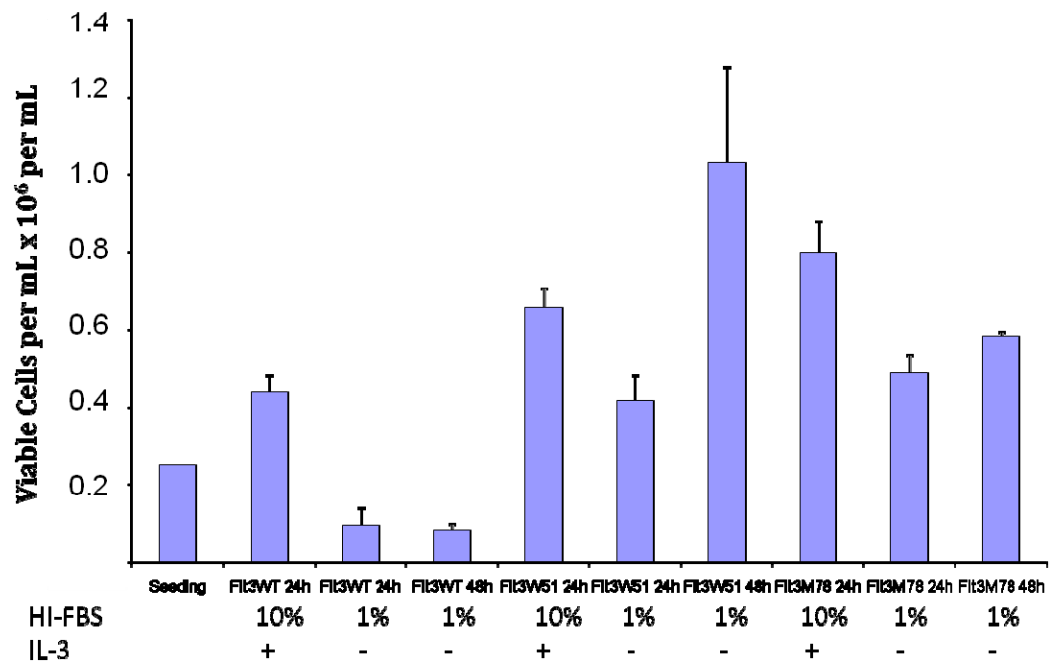

Figure 15. ITD-Flt3 BaF3 Cells Show Increased Cdc2-Tyr15 Phosphorylation and Cell Survival. A) Exponentially growing BaF3 cells transduced with wt-Flt3 or ITD-Flt3 N51 and N78 mutants were washed with PBS, counted and 2.5×10^5 cells were cultured in triplicate in 6-well tissue culture plates for 24 hours in RPMI media containing 10% HI-FBS and 100 pg/mL IL-3 “24h Exp Gr” or 24 and 48 hours in 1% FBS/IL-3-depleted RPMI media to induce apoptosis. Cells were harvested, lysates prepared and 100 ug of each sample run on SDS-PAGE gels and immublot analysis performed for phosphoTyrosine-15 Cdc2, total Cdc2 and Survivin. B) Exponentially growing BaF3 cells transduced with wt-Flt3 or ITD-Flt3 N51 and N78 mutants were washed with PBS, counted and 2.5×10^5 cells were cultured in triplicate in 6-well tissue culture plates for 24 hours in RPMI media containing 10% HI-FBS and 100 pg/mL IL-3 or 24 and 48 hours in RPMI media containing 1% HI-FBS and no IL-3. Cell viability was quantitated using trypan blue exclusion. Data are expressed as mean \pm SEM and are representative of 3 experiments.

1% HI-FBS media) over 24 or 48 hours (Figure 15A). We observe a marked increase in phospho-Tyr15-Cdc2 levels and Survivin in the 2 ITD-Flt3 mutants as compared to cells transduced with wt-Flt3. The BaF3 cells transduced with ITD-Flt3 mutants have a higher level of viability compared to cells transduced with wt-Flt3 as measured by total viable cell counts (Figure 15B). The increased viability correlates with the increased phospho-Tyr15-Cdc2 and Survivin levels observed, strongly suggesting the contribution of both in evasion of apoptosis.

Phospho-Tyr15-Cdc2 Levels Are Not Due to An Increase in S-Phase

It is possible that the observed increase in phospho-Tyr15-Cdc2 levels in wt-Survivin transduced cells could be due to an increase in the number of cells in S or G₂-phase, since p34Cdc2 is reported to be required for progression from G₂ into Mitosis and is activated (dephosphorylated by Cdc25c). Exponentially growing control and wt-Survivin transduced cells were stained with propidium iodide and cell cycle stage analyzed using flow cytometry. No significant difference in the proportion of cells in the S and G₂/M phases was observed in these cells (Figure 16). It is difficult to separate G₂ from M phase in BaF3 cells therefore the two are expressed together.

Wt-Survivin Does Not Directly Interact with Wee1 Kinase

To further investigate the mechanism whereby Survivin up-regulates phospho-Tyrosine-15 p34Cdc2 levels, we tested whether there was a direct binding between Survivin and Wee1. We hypothesized that a physical interaction between Survivin and Wee1 would allow Survivin to act as a scaffold between Wee1 and p34Cdc2 and thereby

Figure 16

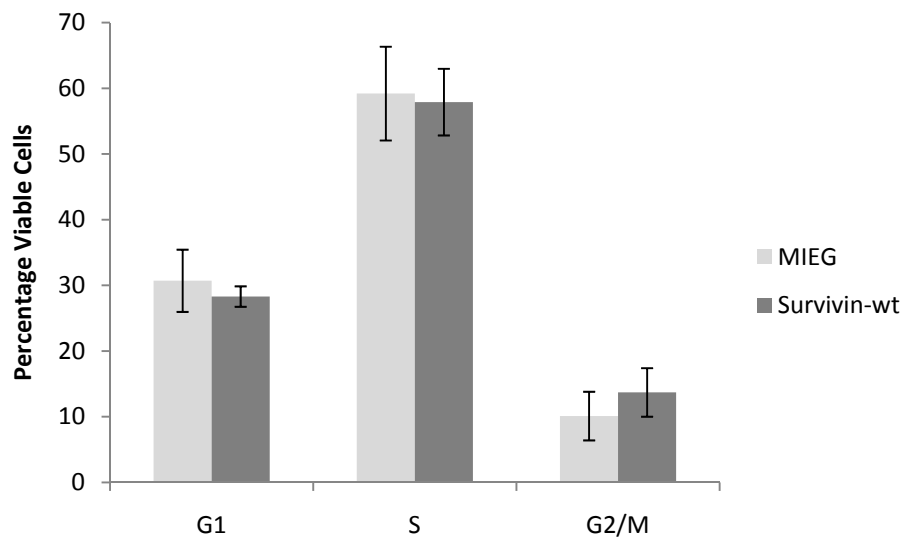

Figure 16. Cell Cycle Analysis. The graph shows the percentage of viable, exponentially growing MIEG or wt-Survivin transduced BaF3 cells in the various stages of cell cycle. Exponentially growing cells were harvested, washed with PBS, counted and 1×10^6 cells fixed with 1% paraformaldehyde, permeabilized and stained with propidium iodide then analyzed by flow cytometry to determine the various stages of cell cycle within the . N=3, no significant difference exists between the groups. The percentage of cells in each stage of the cell cycle is expressed as Mean \pm SEM.

enhance phospho-Tyr15-Cdc2 levels. Using lysates from MIEG, wt- and dn-T34A-Survivin transduced BaF3 cells, we performed immunoprecipitation of both Survivin and Wee1 proteins using 2.5 mg of whole cell lysates pre-cleared with A/G agarose beads. The immunoprecipitates and whole cell lysate controls were run on SDS- PAGE and immunoblotted for Survivin and Wee1 kinase. Although Wee1 and Survivin could be independently immunoprecipitated and detected, no co-immunoprecipitation was observed (Figure 17a). Since the results could be due to antibody-mediated inhibition of association between these two proteins or a result of human Survivin not interacting with endogenous murine Wee1, we repeated the experiments using human Jurkat T-cells, which express high endogenous levels of both Wee1 and Survivin. Similar to BaF3 cells we observed independent immunoprecipitation and detection of Survivin and Wee1 but no direct binding between Wee1 and Survivin (Figure 17b).

Wt-Survivin Increases Wee1 Kinase Protein Levels

Since the Wee1 kinase can phosphorylate Cdc2 on Tyrosine-15, we probed lysates from BaF3 cells over-expressing wt-Survivin or dn-T34A-Survivin for Wee1. Cells over-expressing Survivin showed 2-fold higher levels of Wee1 protein compared to control MIEG and dn-T34A-Survivin transduced cells, the latter showing almost no detectable levels of Wee1 protein expression (Figure 18). These results suggested that Survivin increases Cdc2-Tyr15 phosphorylation levels by increasing total levels of Wee1 kinase.

Figure 17
A.

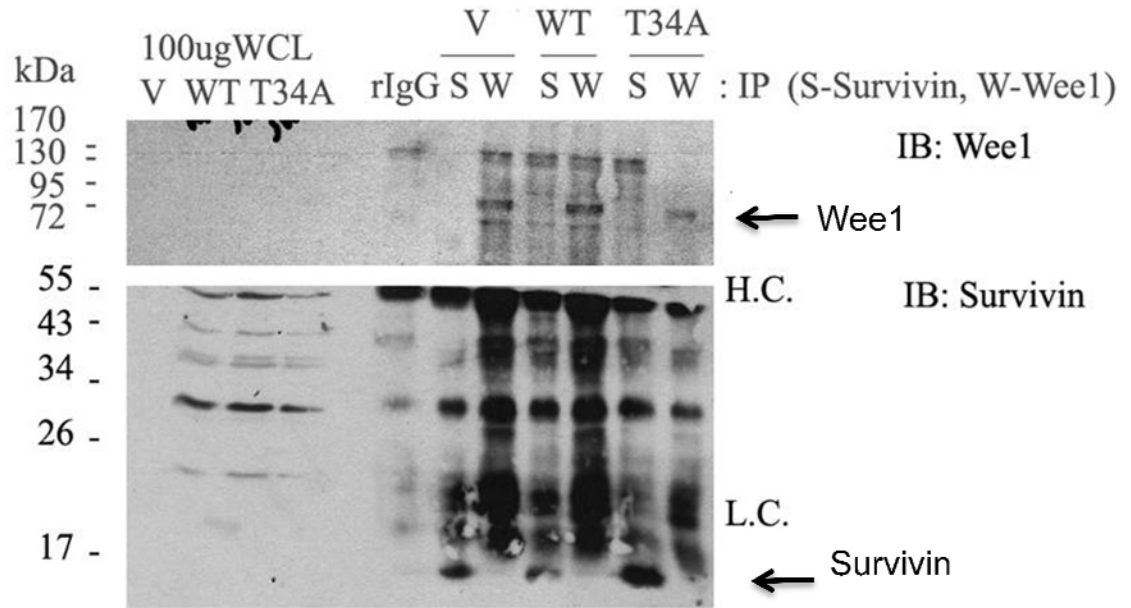

B.

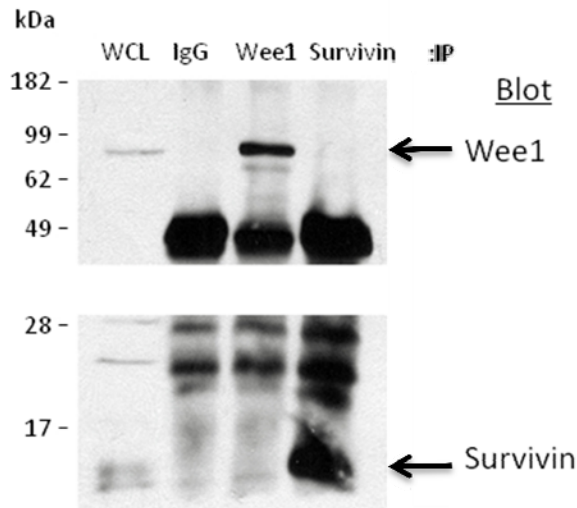

Figure 17. Immunoprecipitation of Survivin and Wee1 from human Jurkat T Cells.

A) Exponentially growing MIEG-, wt-Survivin and dn-T34A-Survivin transduced BaF3 cells were harvested, lysates prepared and 2.5 mg of total cell lysate used for each immunoprecipitation of Survivin (S) and Wee1 kinase (W). Normal non-specific rabbit IgG (rIgG) was used as a control immunoprecipitation and 100 ug of total cell lysate from each sample were used as control. After samples were run on 8-15% gradient SDS-PAGE gels, immunoblotting was performed using anti-Survivin and anti-Wee1 antibodies. B) Exponentially growing Jurkat T-cells were harvested, lysates prepared and 1 mg of total cell lysate used for control non-specific rabbit IgG immunoprecipitation (IgG) as well as immunoprecipitation of Survivin and Wee1 kinase. One hundred micrograms of total cell lysate was run along side as a control on SDS-PAGE gels. Immunoblot analysis was performed using anti- Survivin and anti-Wee1 antibodies.

Figure 18

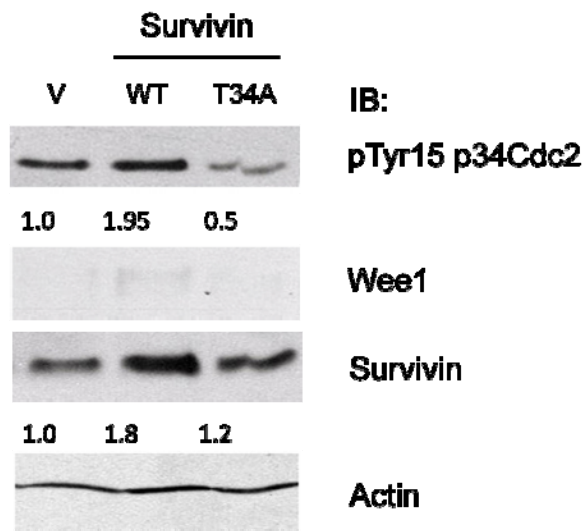

Figure 18. Wee1 Kinase is Elevated in wt-Survivin Over-Expressing Cells. Western blot analysis for Wee1 kinase, phospho-Tyrosine15 p34Cdc2, Survivin and β -Actin. Exponentially growing BaF3 cells over-expressing MIEG vector, wt-Survivin or dn-T34A-Survivin were harvested, lysates prepared and 100 ug of each run on SDS-PAGE gel. Immunoblotting analysis was performed followed by densitometric analysis of the bands, all standardized first to β -Actin then again standardized to MIEG control (MIEG = 1.0). Relative standardization is shown below the bands. Data are representative of 5 experiments.

Chapter 2

Survivin Protects Wee1 Kinase

Survivin Over-Expression is Sufficient to Maintain phospho-Tyr15-Cdc2 and Wee1 Protein Levels

We have shown that Survivin maintains Tyrosine-15 phosphorylation of p34Cdc2, which is associated with higher levels of Wee1 protein (Figure 18). Since Wee1 is a target of caspase-3 [143, 144] and Survivin inhibits caspase-3 [54], we evaluated whether elevated Wee1 protein detected in cells ectopically expressing wt-Survivin was a result of Survivin protecting Wee1 from degradation by caspase-3. We first performed a dose response curve using the specific caspase-3 inhibitor, Ac-DEVD-CHO, for 2 hours post a 2 hour incubation in serum-free media (Figure 19) and observed that there was not only an increase in phospho-Tyr15-Cdc2 levels but also an increase in the caspase-3 target whole Poly (ADP-Ribose) Polymerase (PARP), levels of which are a coincident measure of the inhibition of caspase-3 activity. Peak elevation of phospho-Tyr15-Cdc2 was observed at 25 and 50 μ M. We next compared MIEG and wt-Survivin-transduced BaF3 cells treated for 2 hours with DMSO vehicle control or 50 μ M of Ac-DEVD-CHO after a 2 hour incubation in serum-free media, and analyzed the harvested cell lysates by immunoblotting. The levels of phospho-Tyr15-Cdc2 were increased (4-fold) in MIEG-transduced cells in the presence of the caspase-3 inhibitor however the levels of phospho-Tyr15-Cdc2 were unaffected by pharmacological caspase inhibition in

Figure 19

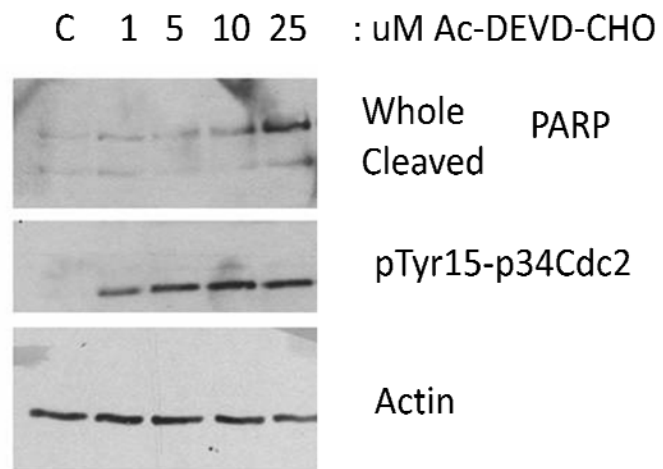

Figure 19. Ac-DEVD-CHO Concentration Curve Correlates with Increased Phospho-Tyr15-Cdc2. Exponentially growing MIEG-transduced BaF3 cells were washed with PBS, counted and 2.5×10^6 cells per well placed in serum-free RPMI media in 6-well tissue culture plates for two hours. Cells were then treated with vehicle control DMSO or a specific caspase-3 inhibitor Ac-DEVD-CHO at increasing concentrations of 1, 5, 10 and 25 μ M for 2 hours. Cells were subsequently harvested, lysates prepared and 100 μ g of each sample run on SDS-PAGE for immunblotting analysis of PARP, phospho-Tyrosine15-Cdc2 and β -actin levels.

Figure 20

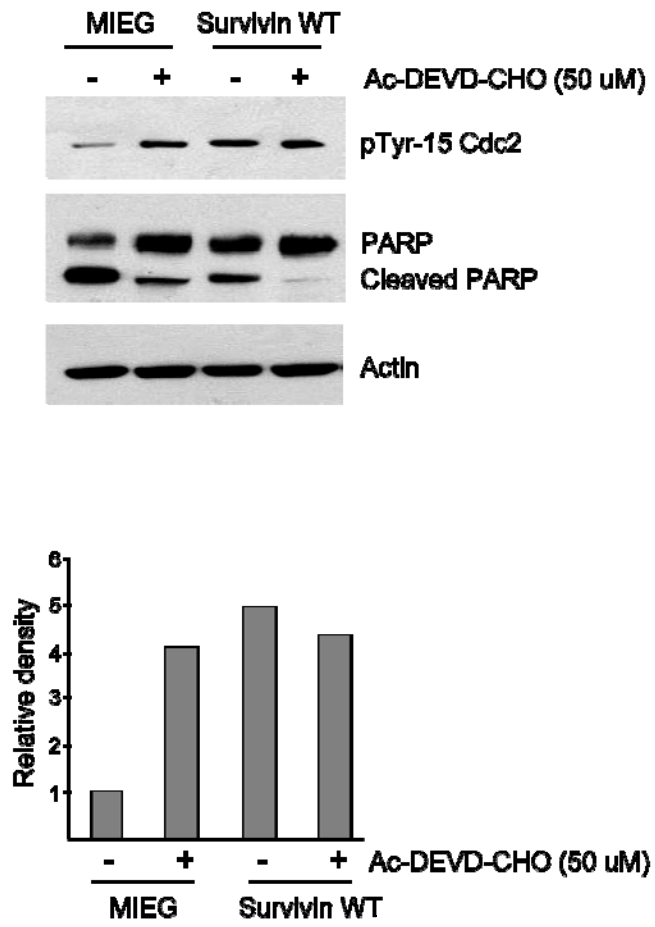

Figure 20. Survivin Over-Expression is Sufficient to Maintain Phospho-Tyr15-Cdc2

Levels. Exponentially growing MIEG control and wt-Survivin transduced BaF3 cells were harvested, washed with PBS, counted and 2.5×10^6 cells per well placed in serum-free RPMI media in 6-well tissue cultures plates. Cells were treated with 50 μ M of the caspase-3 inhibitor Ac-DEVD-CHO or DMSO control for 2 hours. Cells were harvested, lysates prepared and 100 μ g of each sample run on SDS-PAGE for immunoblotting analysis of phospho-Tyrosine-15 Cdc2 (pTyr15-Cdc2), PARP and β -Actin.

wt-Survivin over-expressing cells (Figure 20). Reduction in the levels of cleaved PARP verified that the Ac-DEVD-CHO effectively reduced caspase-3 activity.

In order to determine if increased Tyr15 phosphorylation of Cdc2 was due solely to inhibition of caspase-3, additional studies were performed using the selective Caspase-7 inhibitor Ac-LEHD-CHO and the pan-caspase inhibitor Z-VAD-FMK. In control MIEG-transduced cells, all three inhibitors increased the levels of phospho-Tyr15-Cdc2 with no effect on total Cdc2 (Figure 21). The highest levels of phospho-Tyr15-Cdc2 were seen in cells treated with the pan-caspase inhibitor Z-Vad-FMK. In cells over-expressing Survivin, ectopic Survivin was sufficient to maintain elevated phospho-Tyr15-Cdc2 levels, which could not be increased further in the presence of these pharmacological caspase inhibitors. Whole PARP levels increased primarily in the Ac-DEVD-CHO treated cells. The levels of Wee1 were generally higher in wt-Survivin over-expressing cells than in the MIEG-transduced cells except when vector cells were treated with the pan-caspase inhibitor Z-Vad-FMK. Though varying slightly, all Wee1 protein levels stayed at or above 2-fold over control-treated levels. The effect of caspase-7 inhibition on Wee1 and phospho-Tyr15-Cdc2 levels suggests that perhaps other caspases may be involved in this process.

Caspase-3 is Required to Cause A Change to Wee1 Levels

In order to further define a specific requirement for caspase-3 inhibition in the increased phospho-Tyr15-Cdc2 and Wee1 protein levels seen in wt-Survivin-transduced BaF3 cells, we performed similar studies in MCF7 breast cancer cells, which lack

Figure 21

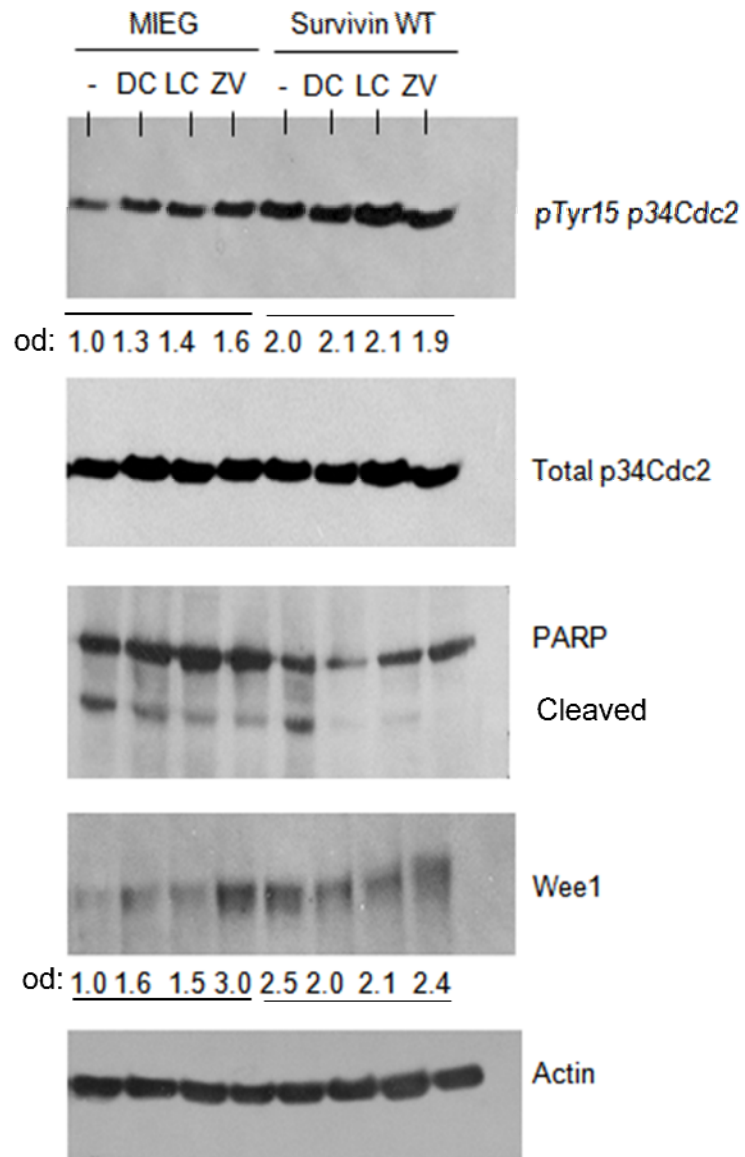

(-) - DMSO Vehicle Control
DC - 25 μ M Ac-DEVD-CHO
LC - 25 μ M Ac-LEHD-CHO
ZV - 20 μ M Z-VAD-FMK

Figure 21. Pharmacological Inhibition with other Caspase Inhibitors. Exponentially growing MIEG and wt-Survivin transduced BaF3 cells were harvested, counted, washed with PBS and plated at 2.5×10^6 cells per well in 6-well tissue culture plates in serum-free RPMI media for 2 hours. Cells were then treated with either Ac-DEVD-CHO (DC) (25uM), Ac-LEHD-CHO (LC) (25uM) or Z-VAD-FMK (ZV) (20uM) or DMSO vehicle control for 2 hours. Cells were harvested, lysates prepared and 100 ug of each sample run on SDS-PAGE for immunoblotting analysis of phospho-Tyr15-Cdc2, total p34Cdc2, PARP, Wee1 kinase and β -Actin. Densitometric analysis comparing phospho-Tyr15-Cdc2 to total Cdc2 levels and Wee1 to β -Actin levels are shown under the respective blots, standardizing to MIEG vehicle control = 1.0. Data are representative of 2 independent experiments.

caspase-3 protein as a result of a 47-bp deletion in the corresponding gene [135]. In contrast to BaF3 cells, no increase in Wee1 protein, Tyr15-Cdc2 phosphorylation, total p34Cdc2 or changes in PARP were observed when MCF7 cells were treated with the caspase-3 inhibitor Ac-DEVD-CHO, the caspase-7 inhibitor Ac-LEHD-CHO or the pan-caspase inhibitor Z-VAD-FMK, strongly suggesting that caspase inhibition is required for Survivin-mediated enhancement of phospho-Tyr15-Cdc2 and Wee1 protein levels (Figure 22). The fact that the pan-caspase inhibitor and caspase-7 inhibitors did not affect Wee1 protein levels or Tyr15 p34Cdc2 phosphorylation suggests that the effects seen in the BaF3 cells are specific to caspase-3.

Destabilization of Survivin Abrogates the Effect on Wee1

Survivin protein is stabilized by interacting with the heatshock protein Hsp90 [22, 83, 145]. We therefore evaluated whether blocking Survivin-Hsp90 interaction would block increased Cdc2 phosphorylation to further confirm a specific role for Survivin in increasing Cdc2 phosphorylation and Wee1 protein levels. BaF3 cells over-expressing wt-Survivin were treated with the Hsp90 inhibitor AICAR or DMSO vehicle for 1, 2, 5 or 6 hours and lysates analyzed for Tyr15-Cdc2 phosphorylation levels. No effect of AICAR on phospho-Tyr15-Cdc2 levels were observed during the first 2 hours of treatment, however at 5 hours the levels of phospho-Tyr15-Cdc2 in BaF3 cells treated with the Hsp90 inhibitor were significantly lower than untreated cells. The effect was even more pronounced at 6 hours, where essentially no phospho-Tyr15-Cdc2 was detected (Figure 23). Consistent with the destabilizing effects of Hsp90 inhibitors on

Figure 22

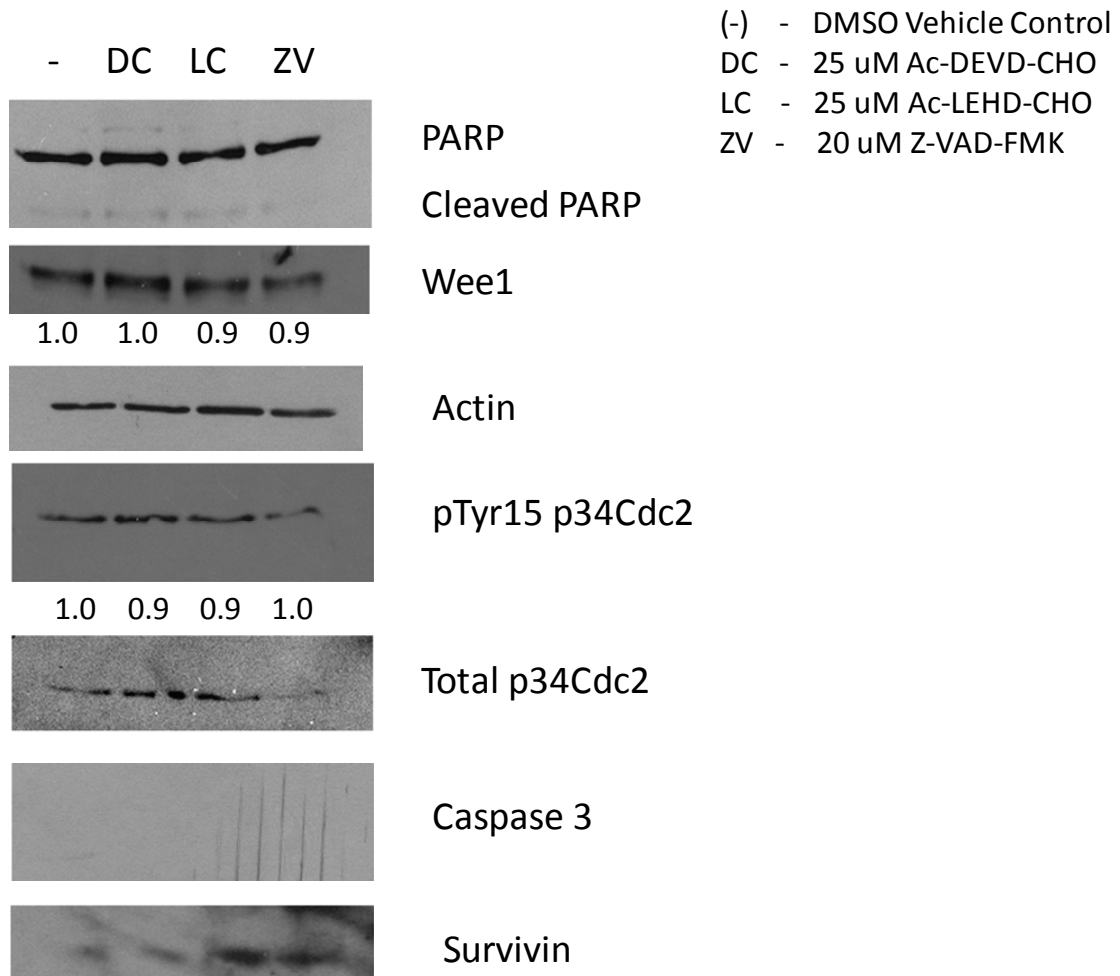

Figure 22. Treatment of MCF7 Cells with Caspase Inhibitors Has No Effect on Phospho-Tyr15-Cdc2 or Wee1 Protein Levels. MCF7 cells were harvested by trypsinization, washed with PBS, counted and plated at 2.5×10^6 cells in 10 cm tissue culture plates for 24 hours in α -MEM media. Cells were then treated with Ac-DEVD-CHO, Ac-LEHD-CHO, Z-VAD-FMK or dmsso vehicle control for 2 hours. The cells were harvested, lysates prepared and 100 ug of each sample run on SDS-PAGE for immunoblotting analysis of PARP, Wee1, β -actin, phospho-Tyrosine-15 p34Cdc2, total Cdc2, caspase3 and Survivin levels. Densitometric analysis for Wee1 standardized to β -actin and phospho-Tyr15-Cdc2 standardized to total Cdc2 are shown under the respective blots and expressed relative to vehicle control set at 1.0. Data are representative of 3 experiments with similar results.

Figure 23

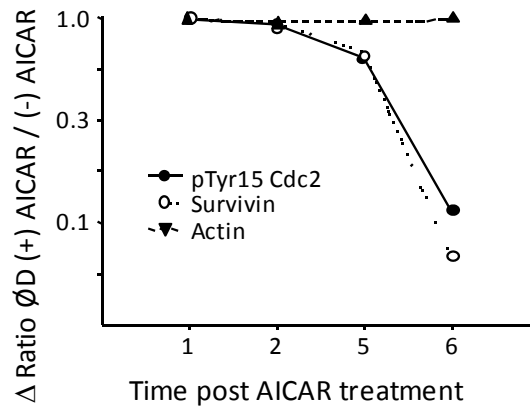
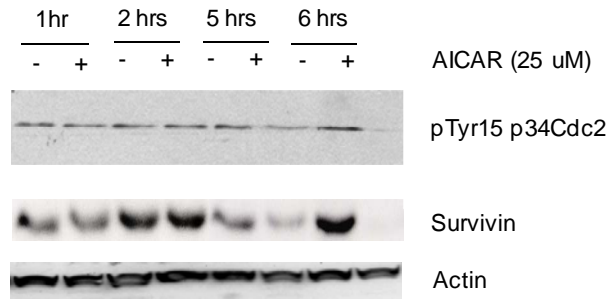

Figure 23. Inhibition of Hsp90 by AICAR Treatment Decreases Phospho-Tyr15-Cdc2 Levels in wt-Survivin Over-Expressing Cells. Exponentially growing wt-Survivin transduced BaF3 cells were harvested, washed with PBS, counted and plated at 2.5×10^6 cells per well in 6-well tissue culture plates. Cells were treated with the Hsp90 inhibitor AICAR (25 μ M) or dmsO vehicle control for 1, 2, 5 or 6 hours. At each time point control and AICAR treated cells were harvested, lysates prepared and 100 μ g of each sample run on SDS-PAGE for immunoblotting analysis of phosphoTyrosine-15 p34Cdc2, Survivin and β -actin levels. A plot of the densitometric analysis for the ratios of phosphoTyrosine-15 p34Cdc2 (pTyr15 p34Cd2), Survivin and β -actin for untreated cells relative to AICAR treated cells in each time point is shown below the blot.

Survivin protein stability, Survivin protein levels were reduced coincident with reduction in phospho-Tyr15-Cdc2.

In similar fashion, treatment of BaF3 cells expressing wt-Survivin with 100 nM 17-AAG, a Geldanamycin-derivative, that blocks the Hsp90 ATP-binding site, resulted in a decrease in Wee1 protein (52%), phospho-Tyr15-Cdc2 (82%), Survivin (68%) and whole PARP levels (67%) after 24 hours treatment coincident with reduced levels of Hsp90 protein (67%) (Figure 24).

p21^{cip1/waf1} is Elevated in wt-Survivin Over-Expressing BaF3 Cells

Previous studies by our laboratory indicate that the CDKI p21^{cip1/waf1} forms an axis with Survivin and is necessary in part for some of its effects. We compared MIEG and wt-Survivin transduced BaF3 cells and observed an increase in p21, whole PARP, phospho-Tyr15-Cdc2 and Survivin levels in wt-Survivin transduced cells compared to MIEG control (Figure 25). It has been suggested that p21 binds to procaspase-3 to help inhibit its cleavage and activation but is also a target of caspase-3 mediated cleavage. Therefore, Survivin may have the same effect on p21 levels as Wee1. Since p21 also binds to and inhibits p34Cdc2, Survivin-mediated p21 up-regulation may be another pathway involved in Survivin-mediated enhancement of Wee1.

Figure 24

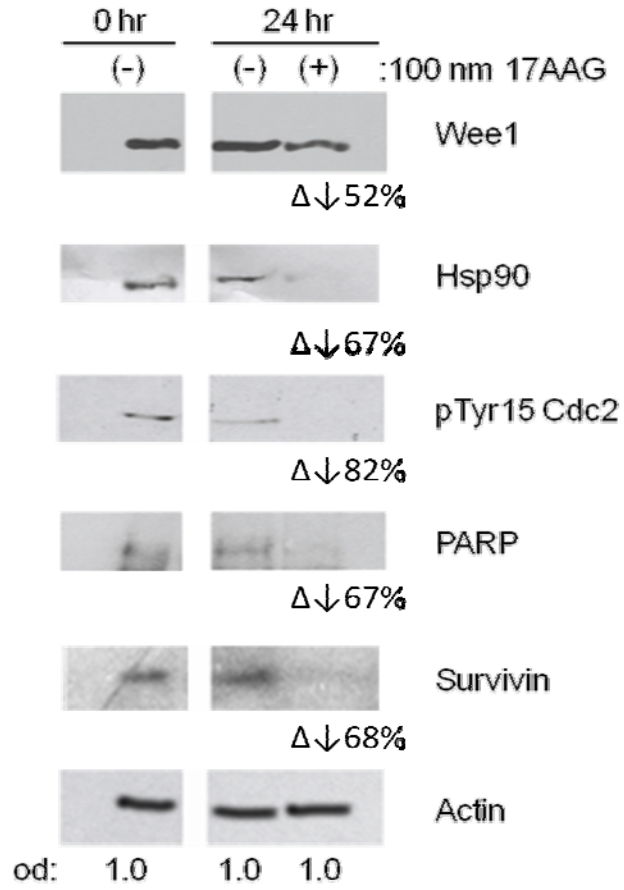

Figure 24. 17-AAG Treatment of wt-Survivin Over-Expressing BaF3 Cells.

Exponentially growing wt-Survivin transduced BaF3 cells were treated, harvested, washed with PBS, counted and 2.5×10^6 cells per well cultured in serum-free RPMI in 6-well tissue culture plates. Cells were treated with 100 nM 17-AAG or DMSO vehicle control for 24 hrs and cells harvested, lysates prepared and 100 ug of each sample run on SDS-PAGE for immunoblotting of phospho-Tyr15-Cdc2, PARP, Survivin, Hsp90, β -Actin and Survivin levels. Relative expression of each protein in 17-AAG treated cells as compared to vehicle control is expressed as delta percentage change. Lysates from cells at baseline (time 0 hr) are included as controls.

Figure 25

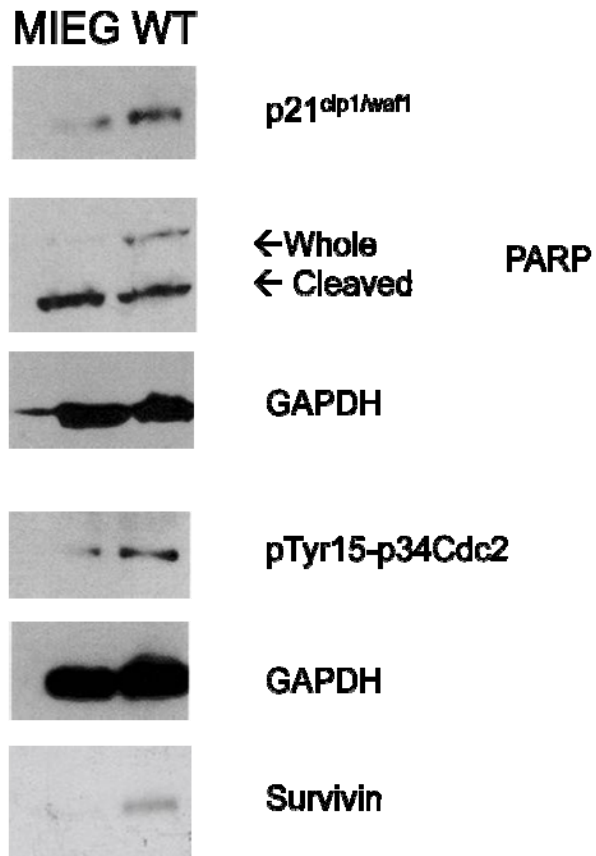

Figure 25. p21^{cip1/waf1} Protein Elevation Correlates with Increased Survivin and Phospho-Tyr15-Cdc2 Levels. Exponentially growing MIEG control and wt-Survivin transduced BaF3 cells were harvested, lysates prepared and 100 ug (top 3 blots) or 50 ug (bottom 3 blots) of each sample run on SDS-PAGE for immunoblotting analysis of p21^{cip1/waf1}, PARP, GAPDH, phospho-Tyr15-Cdc2 and Survivin levels.

Unified Model of Survivin-Mediated Increase in Phospho-Tyr15-Cdc2 and Inhibition of Apoptosis

Signaling pathway inhibition studies suggest that signaling through the Ras-Raf-Mek-Erk or PI3K-Akt pathways maintains Survivin levels, which leads to increased inhibition of caspase-3 activity. This decrease in caspase-3 activity in turn results in an increase of Wee1 protein levels, which leads to an increase in Cdc2-Tyr15 inhibitory phosphorylation. Our data also shows that p21^{cip1/waf1} levels are increased, and as a result may help inhibit both caspase-3 activation and Cdc2 activity. We therefore have defined a pathway through which Survivin inhibition of caspase-3 activity maintains or elevates the Wee1 kinase that inhibits the apoptotic function of the Cdc2 kinase thereby promoting cell proliferation and survival (Figure 26).

Figure 26

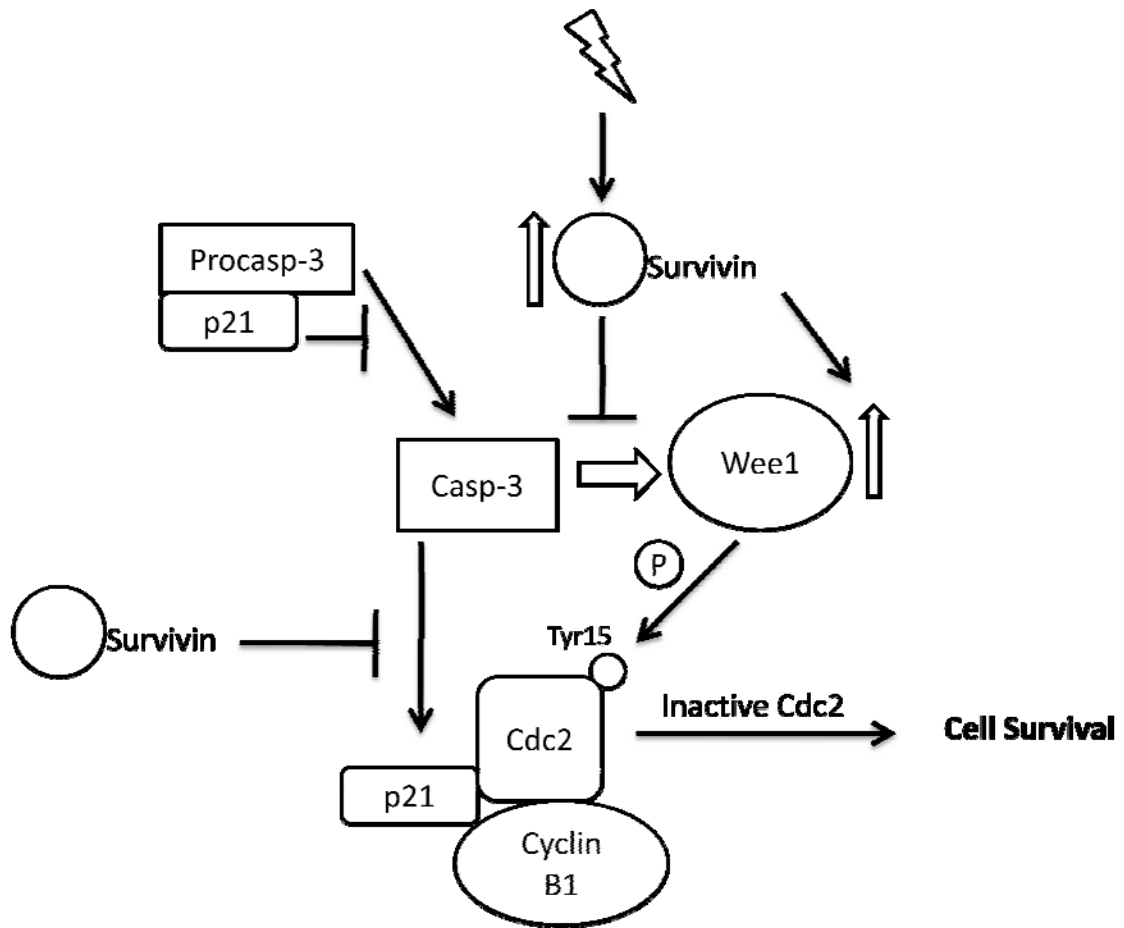

Figure 26. Unifying Model of Survivin's Effect on Cdc2 Inactivation and Inhibition of Apoptosis.

Increase in Survivin protein levels results in increased inhibition of caspase-3 activity. In turn, there is an increase in the protein levels of Wee1 kinase which phosphorylates cytoplasmic Cdc2 on Tyrosine-15 thereby preventing dysregulated Cdc2 activation and ultimately helping to evade apoptosis and promote cell survival. Since Survivin over-expression also elevates protein levels of p21^{cip1/waf1}, the literature suggests this increase should also aid anti-apoptotic activity through binding of p21^{cip1/waf1} to procaspase-3 and blocking caspase-3 activation as well as physically interacting with and inhibiting Cdc2.

DISCUSSION

A number of studies show that Survivin over-expression confers resistance to apoptosis that is mediated through the inhibition of proapoptotic proteins such as caspases 3, 7 and 9 [8, 20, 146]. We have found that Survivin over-expression also increases phosphorylation of p34Cdc2 on Tyrosine-15. Although Cdc2 can promote mitosis, it can also mediate apoptosis, and phosphorylation of p34Cdc2 at Tyrosine-15 inactivates Cdc2 blocking its pro-apoptotic activity [131, 137-140]. Increased phospho-Tyr15-Cdc2 is consistent both with the role of Cdc2 and the action of the anti-apoptotic protein Survivin. However, since Survivin does not contain intrinsic kinase activity, it is not clear how Cdc2 phosphorylation is achieved. Herein, we show that Survivin increases the level of the Wee1 kinase that phosphorylates Cdc2 by blocking Wee1 degradation by caspase-3. The increase in Wee1 protein and Tyrosine-15 phosphorylation of Cdc2 directly correlates with increased survival in cells expressing ectopic wild-type Survivin. To our knowledge this is the first report demonstrating a functional link between the Wee1 kinase and Survivin.

A functional link between Survivin and Cdc2 has been previously reported [18], however cross-talk between the two proteins has recently come into question. Several reports show a correlation between Cdc2 activation and apoptosis [131, 137-140], thus it makes sense that Cdc2 inactivation correlates with Survivin over-expression. However, an association between induction of increased Survivin and an increase in p34Cdc2 activation in response to ethanol in a gastric epithelial cell line model was recently

reported [147]. Although these findings seem contradictory to our findings in normal hematopoietic cells, differences in normal versus transformed cells could be responsible. Also, in the gastric epithelial model it is assumed that active Cdc2 results in increased Survivin stabilization and thus the two are upregulated simultaneously. However, we show that an increase in Survivin expression in turn has a down-regulatory effect on Cdc2 activity through Wee1 kinase protection from caspase-3 mediated degradation, thus forming a negative feedback loop resulting in enhanced evasion of apoptosis. Our proposed regulatory role of Survivin and p34Cdc2 is consistent with our previous report that Survivin functions as a regulatory element in the Mdm2-p53 pathway, where it reduces p53 protein and mRNA through protection of Mdm2 from caspase-mediated degradation [61].

In further support of the role of Survivin in increasing phosphorylation of Tyr15-Cdc2 as a mechanism to increase cell survival, we used a leukemia cell model that increases Survivin protein levels through constitutively active ITD-Flt3 mutant receptors. This model affords the opportunity to study Survivin and its effects on Cdc2-Tyr15 phosphorylation in a manner that more closely resembles Survivin up-regulation *in vivo*. We observed a significant increase in phospho-Tyr15-Cdc2 levels that correlated with increased cell survival in cells transduced with the ITD-Flt3 mutants compared to control cells transduced with wt-Flt3 when we cultured these cells in pro-apoptotic conditions. These results strongly support the link between Survivin, its effect on Tyr15-Cdc2 phosphorylation and increased evasion from apoptosis.

Although Survivin is associated with inhibition of caspase activity, whether it directly binds and inhibits caspase-3 directly is not clear [148-151]. Nevertheless, over-expression of wt-Survivin in our model system resulted in an increase in whole PARP levels as compared to cells over-expressing vector alone and PARP cleavage is an established measure of active caspase-3 [152]. We have also shown that ectopic Survivin is sufficient to maintain phospho-Tyr15-Cdc2 levels even in the presence of an exogenous specific caspase-3 inhibitor Ac-DEVD-CHO and that this effect is absent in caspase-3 deficient cells. Taken together these results strongly support Survivin-mediated caspase-3 inhibition, however they do not prove whether this represents a direct effect on caspase-3. We also show that Survivin over-expression is sufficient to maintain higher levels of Wee1 kinase compared to vector-control cells even in the presence of caspase inhibition, and present strong evidence that this effect is mediated through caspase-3 inhibition, although we cannot rule out the involvement of other caspases, at least in BaF3 cells. However, the lack of increase in Wee1 and phospho-Tyr15-Cdc2 levels in MCF7 cells deficient only in caspase-3 strongly suggests that caspase-3 is the primary caspase mediating protection of Wee1. It has been reported that the Wee1 kinase is a caspase-3 target and is associated with resistance to apoptosis [130, 131], similar to Survivin. Thus our finding that Wee1 kinase is upregulated by wt-Survivin over-expression through caspase-3 inhibition is consistent with the mechanism of both proteins.

Caspase-3 has been reported to play a role in the maintenance of the hematopoietic stem cell (HSC) pool [75]. HSCs deficient in caspase-3 show an accelerated proliferation and retarded differentiation. This finding is consistent with our past studies that Survivin is up-regulated in response to growth factors in quiescent CD34⁺ cells and required for their entry into cell cycle [3, 73, 134]. In addition, using a conditional Survivin knockout mouse model, Survivin deletion results in significant impairment in HSC number and HSC function (Fukuda S. and Pelus, L.M. unpublished). Taken together these studies indicate that Survivin and caspase-3 are intimately involved in HSC function. Increased caspase-3 inhibition by Survivin maintains the stem cell pool and loss of Survivin protein with subsequent increased caspase-3 activity results in loss of HSC function and perhaps increased cell differentiation. Very little is known about the role of Wee1 kinase in hematopoiesis, and it will be interesting to determine how it is regulated in HSCs and in their differentiated progeny. Since Survivin is up-regulated endogenously in HSCs and initiates proliferation, our present results suggest that regulation of Wee1 protein in these cells is likely directly correlated with Survivin levels. In addition, reports have shown that regulation of Wee1 correlates with cell survival [104, 130, 131, 153, 154]. Thus, evaluation of whether inhibition of Wee1 kinase in Survivin-over-expressing cancers would down-regulate inhibition of apoptosis could identify a novel and effective chemotherapeutic strategy.

SUMMARY

In chapter one, we showed that Survivin over-expression results in increased Tyrosine-15 phosphorylation of p34Cdc2 kinase and this increase correlates with cell survival and proliferation. We were able to confirm these findings in both BaF3 cells that were retrovirally transduced with the wt-Survivin gene as well as in cells that over-expressed Survivin through retroviral transduction of constitutively active tyrosine kinase receptors (ITD-Flt3). This finding is important because it implies a mutual signaling loop between Survivin and p34Cdc2, rather than the proposed pathway whereby Cdc2 together with Cyclin B1 phosphorylates Survivin on Threonine-34 and stabilize the protein. Since Survivin contains no intrinsic kinase activity we verified that this increase in phosphorylation is not due to a build-up of cells in S-phase of cell cycle, where p34Cdc2 is known to be inactive, but rather to an increase in Wee1 kinase protein levels. However, we could not detect a direct association between Wee1 and Survivin in our murine cell line or in human Jurkat-T cells, which would have implicated Survivin as a scaffold protein between p34Cdc2 and Wee1.

In chapter two, we showed that Survivin's effect on Wee1 kinase is caspase-3 dependent and that over-expression of wt-Survivin is sufficient to maintain phosphorylation of Tyrosine-15 of p34Cdc2 even in the presence of additional pharmacological caspase-3 inhibition. This was further proven in MCF7 cells that lack endogenous caspase-3, where pharmacological caspase inhibition was unable to increase Cdc2-Tyr15 phosphorylation. In order to study how disruption of Survivin would affect

the observed effects we utilized two Hsp90 inhibitors AICAR and 17-AAG that destabilize Survivin. Both inhibitors decreased phospho-Tyr15-Cdc2 levels, indicating that it is possible to block the effect of Survivin on Cdc2 phosphorylation. We also found that p21^{cip1/waf1} is elevated in cells over-expressing Survivin, which is another target of caspase-3 and known to inhibit Cdc2 activity, potentially implicating another player in this process.

In summary, our results suggest that Survivin over-expression mediates protection of the Wee1 kinase through inhibition of caspase-3, which in turn leads to an increase in phospho-Tyr15-Cdc2 levels. In the absence of Survivin, caspase-3 is not inhibited, Wee1 is degraded and Cdc2 is activated or kept active and apoptosis is initiated. It is possible that other proteins that affect p34Cdc2 activity, particularly p21^{Cip1/Waf1} that can inhibit Cdc2 [155], and is also a caspase-3 target [156], play an important role in the proliferation of normal hematopoietic stem cells by Survivin [74] may play a role in the anti-apoptotic Survivin-caspase-3-Wee1-Cdc2 axis we have described.

FUTURE STUDIES

In order to study the requirement of Wee1 kinase in Survivin-mediated apoptotic evasion, the use of retroviral vectors to incorporate both wt-Survivin or a dominant-dn-Survivin mutant in combination with a wt-Wee1 or a Wee1 lacking its kinase domain could prove useful. Primary cells could be transduced with the abovementioned viral vectors and apoptosis measured by Annexin V/PI staining, caspase-3 activity assay, TUNEL assays and viable cell counts, either without stimulation or within cytokine and serum-depleted conditions. Another way to stimulate apoptosis in these cells would be by incubating them with FasL or agonist Fas-antibody and then measuring their response. This would establish a more definitive role for Wee1 in Survivin-mediated apoptosis.

Since we have seen that Survivin up-regulates total Wee1 protein levels, it would be worthwhile to evaluate the kinetic activity of Wee1 in wt-Survivin over-expressing cells compared to control cells. MIEG and wt-Survivin transduced cells could be harvested during log-phase of their growth in culture, lysates prepared and Wee1 kinase immunoprecipitated. Equal amounts of immunoprecipitated lysate could then be incubated with small amounts of total lysate from control cells to allow Wee1 to phosphorylate p34Cdc2 on Tyr15, then the resulting lysates run on SDS-PAGE gels and immunoblotted for phospho-Tyr15-Cdc2 levels. Should they show comparable amounts of kinase activity then having more total protein in wt-Survivin over-expressing cells would result in more kinase activity as a result of increase in total protein. However, should the experiment result in higher kinase levels in the wt-Survivin over-expressing

cells, further experiments could be performed studying the pathways potentially regulating Wee1 kinase activity and how Survivin up-regulation is affecting them.

Since we have conditional knockout mice for Survivin, these mice could be used to determine if Wee1 over-expression can compensate for the loss of Survivin in maintaining the hematopoietic stem cell compartment. A competitive repopulation assay could be employed with hematopoietic stem and progenitor cells taken from the Survivin conditional knockouts, the latter could be transduced with vector, Wee1 kinase or kinase-dead Wee1 retroviral vectors and transplanted into bone marrow ablated recipient mice. The ability or inability of the Survivin⁻/Wee1⁺ cells would help better understand the relationship between Wee1 and Survivin that we have defined.

The use of p21^{cip1/waf1} knockout mice would help determine the necessity of p21 in Survivin's effect on Wee1, p34Cdc2 and overall survival. Although our laboratory has already published the necessity of the p21-Survivin axis on survival in a hematopoietic context [74], we have not studied what effect the loss of p21 would have on Wee1 in cells over-expressing Survivin. Either transient and permanent ectopic expression of Survivin in p21^{-/-} cells and measurement of Wee1 protein levels would help define their relationship.

REFERENCES

1. Ambrosini, G., C. Adida, and D.C. Altieri, *A novel anti-apoptosis gene, survivin, expressed in cancer and lymphoma*. Nat Med, 1997. **3**(8): p. 917-21.
2. Adida, C., P.L. Crotty, J. McGrath, D. Berrebi, J. Diebold, and D.C. Altieri, *Developmentally regulated expression of the novel cancer anti-apoptosis gene survivin in human and mouse differentiation*. Am J Pathol, 1998. **152**(1): p. 43-9.
3. Fukuda, S. and L.M. Pelus, *Regulation of the inhibitor-of-apoptosis family member survivin in normal cord blood and bone marrow CD34(+) cells by hematopoietic growth factors: implication of survivin expression in normal hematopoiesis*. Blood, 2001. **98**(7): p. 2091-100.
4. Kornacker, M., M.R. Verneris, B. Kornacker, C. Scheffold, and R.S. Negrin, *Survivin expression correlates with apoptosis resistance after lymphocyte activation and is found preferentially in memory T cells*. Immunol Lett, 2001. **76**(3): p. 169-73.
5. Marconi, A., K. Dallaglio, R. Lotti, C. Vaschieri, F. Truzzi, F. Fantini, and C. Pincelli, *Survivin identifies keratinocyte stem cells and is downregulated by anti-beta1 integrin during anoikis*. Stem Cells, 2007. **25**(1): p. 149-55.
6. Jiang, Y., A. de Bruin, H. Caldas, J. Fangusaro, J. Hayes, E.M. Conway, M.L. Robinson, and R.A. Altura, *Essential role for survivin in early brain development*. J Neurosci, 2005. **25**(30): p. 6962-70.
7. Kobayashi, K., M. Hatano, M. Otaki, T. Ogasawara, and T. Tokuhsa, *Expression of a murine homologue of the inhibitor of apoptosis protein is related to cell proliferation*. Proc Natl Acad Sci U S A, 1999. **96**(4): p. 1457-62.
8. Li, F., G. Ambrosini, E.Y. Chu, J. Plescia, S. Tognin, P.C. Marchisio, and D.C. Altieri, *Control of apoptosis and mitotic spindle checkpoint by survivin*. Nature, 1998. **396**(6711): p. 580-4.
9. Sampath, J. and L.M. Pelus, *Alternative splice variants of survivin as potential targets in cancer*. Curr Drug Discov Technol, 2007. **4**(3): p. 174-91.
10. Altieri, D.C., *Survivin, cancer networks and pathway-directed drug discovery*. Nat Rev Cancer, 2008. **8**(1): p. 61-70.
11. Mellai, M., V. Caldera, A. Patrucco, L. Annovazzi, and D. Schiffer, *Survivin expression in glioblastomas correlates with proliferation, but not with apoptosis*. Anticancer Res, 2008. **28**(1A): p. 109-18.
12. Jiang, L.B., X.Q. Liu, B. Li, X.J. He, Y.L. Jin, L.Q. Li, F. Gao, and N.L. Wang, *Heat shock proteins and survivin: relationship and effects on proliferation index of retinoblastoma cells*. Histol Histopathol, 2008. **23**(7): p. 827-31.
13. Ambrosini, G., C. Adida, G. Sirugo, and D.C. Altieri, *Induction of apoptosis and inhibition of cell proliferation by survivin gene targeting*. J Biol Chem, 1998. **273**(18): p. 11177-82.
14. Li, F. and D.C. Altieri, *Transcriptional analysis of human survivin gene expression*. Biochem J, 1999. **344 Pt 2**: p. 305-11.

15. Xu, R., P. Zhang, J. Huang, S. Ge, J. Lu, and G. Qian, *Sp1 and Sp3 regulate basal transcription of the survivin gene*. *Biochem Biophys Res Commun*, 2007. **356**(1): p. 286-92.
16. Chantalat, L., D.A. Skoufias, J.P. Kleman, B. Jung, O. Dideberg, and R.L. Margolis, *Crystal structure of human survivin reveals a bow tie-shaped dimer with two unusual alpha-helical extensions*. *Mol Cell*, 2000. **6**(1): p. 183-9.
17. Verdecia, M.A., H. Huang, E. Dutil, D.A. Kaiser, T. Hunter, and J.P. Noel, *Structure of the human anti-apoptotic protein survivin reveals a dimeric arrangement*. *Nat Struct Biol*, 2000. **7**(7): p. 602-8.
18. O'Connor, D.S., D. Grossman, J. Plescia, F. Li, H. Zhang, A. Villa, S. Tognin, P.C. Marchisio, and D.C. Altieri, *Regulation of apoptosis at cell division by p34cdc2 phosphorylation of survivin*. *Proc Natl Acad Sci U S A*, 2000. **97**(24): p. 13103-7.
19. Bolton, M.A., W. Lan, S.E. Powers, M.L. McClelland, J. Kuang, and P.T. Stukenberg, *Aurora B kinase exists in a complex with survivin and INCENP and its kinase activity is stimulated by survivin binding and phosphorylation*. *Mol Biol Cell*, 2002. **13**(9): p. 3064-77.
20. Song, Z., X. Yao, and M. Wu, *Direct interaction between survivin and Smac/DIABLO is essential for the anti-apoptotic activity of survivin during taxol-induced apoptosis*. *J Biol Chem*, 2003. **278**(25): p. 23130-40.
21. Rodriguez, J.A., S.W. Span, C.G. Ferreira, F.A. Kruyt, and G. Giaccone, *CRM1-mediated nuclear export determines the cytoplasmic localization of the antiapoptotic protein Survivin*. *Exp Cell Res*, 2002. **275**(1): p. 44-53.
22. Fortugno, P., E. Beltrami, J. Plescia, J. Fontana, D. Pradhan, P.C. Marchisio, W.C. Sessa, and D.C. Altieri, *Regulation of survivin function by Hsp90*. *Proc Natl Acad Sci U S A*, 2003. **100**(24): p. 13791-6.
23. Wheatley, S.P., A. Carvalho, P. Vagnarelli, and W.C. Earnshaw, *INCENP is required for proper targeting of Survivin to the centromeres and the anaphase spindle during mitosis*. *Curr Biol*, 2001. **11**(11): p. 886-90.
24. Wheatley, S.P., A.J. Henzing, H. Dodson, W. Khaled, and W.C. Earnshaw, *Aurora-B phosphorylation in vitro identifies a residue of survivin that is essential for its localization and binding to inner centromere protein (INCENP) in vivo*. *J Biol Chem*, 2004. **279**(7): p. 5655-60.
25. Stauber, R.H., W. Mann, and S.K. Knauer, *Nuclear and cytoplasmic survivin: molecular mechanism, prognostic, and therapeutic potential*. *Cancer Res*, 2007. **67**(13): p. 5999-6002.
26. Mahotka, C., J. Liebmann, M. Wenzel, C.V. Suschek, M. Schmitt, H.E. Gabbert, and C.D. Gerharz, *Differential subcellular localization of functionally divergent survivin splice variants*. *Cell Death Differ*, 2002. **9**(12): p. 1334-42.

27. Noton, E.A., R. Colnaghi, S. Tate, C. Starck, A. Carvalho, P. Ko Ferrigno, and S.P. Wheatley, *Molecular analysis of survivin isoforms: evidence that alternatively spliced variants do not play a role in mitosis*. J Biol Chem, 2006. **281**(2): p. 1286-95.
28. Mahotka, C., M. Wenzel, E. Springer, H.E. Gabbert, and C.D. Gerharz, *Survivin-deltaEx3 and survivin-2B: two novel splice variants of the apoptosis inhibitor survivin with different antiapoptotic properties*. Cancer Res, 1999. **59**(24): p. 6097-102.
29. Knauer, S.K., C. Bier, P. Schlag, J. Fritzmann, W. Dietmaier, F. Rodel, L. Klein-Hitpass, A.F. Kovacs, C. Doring, M.L. Hansmann, W.K. Hofmann, M. Kunkel, C. Brochhausen, K. Engels, B.M. Lippert, W. Mann, and R.H. Stauber, *The survivin isoform survivin-3B is cytoprotective and can function as a chromosomal passenger complex protein*. Cell Cycle, 2007. **6**(12): p. 1502-9.
30. Li, F., *Role of survivin and its splice variants in tumorigenesis*. Br J Cancer, 2005. **92**(2): p. 212-6.
31. Islam, A., H. Kageyama, K. Hashizume, Y. Kaneko, and A. Nakagawara, *Role of survivin, whose gene is mapped to 17q25, in human neuroblastoma and identification of a novel dominant-negative isoform, survivin-beta/2B*. Med Pediatr Oncol, 2000. **35**(6): p. 550-3.
32. Mahotka, C., T. Krieg, A. Krieg, M. Wenzel, C.V. Suschek, M. Heydthausen, H.E. Gabbert, and C.D. Gerharz, *Distinct in vivo expression patterns of survivin splice variants in renal cell carcinomas*. Int J Cancer, 2002. **100**(1): p. 30-6.
33. Krieg, A., C. Mahotka, T. Krieg, H. Grabsch, W. Muller, S. Takeno, C.V. Suschek, M. Heydthausen, H.E. Gabbert, and C.D. Gerharz, *Expression of different survivin variants in gastric carcinomas: first clues to a role of survivin-2B in tumour progression*. Br J Cancer, 2002. **86**(5): p. 737-43.
34. Yamada, Y., T. Kuroiwa, T. Nakagawa, Y. Kajimoto, T. Dohi, H. Azuma, M. Tsuji, K. Kami, and S. Miyatake, *Transcriptional expression of survivin and its splice variants in brain tumors in humans*. J Neurosurg, 2003. **99**(4): p. 738-45.
35. Meng, H., C.D. Lu, Y.L. Sun, D.J. Dai, S.W. Lee, and N. Tanigawa, *Expression level of wild-type survivin in gastric cancer is an independent predictor of survival*. World J Gastroenterol, 2004. **10**(22): p. 3245-50.
36. Takashima, H., T. Nakajima, M. Moriguchi, S. Sekoguchi, T. Nishikawa, T. Watanabe, T. Katagishi, H. Kimura, M. Minami, Y. Itoh, K. Kagawa, and T. Okanoue, *In vivo expression patterns of survivin and its splicing variants in chronic liver disease and hepatocellular carcinoma*. Liver Int, 2005. **25**(1): p. 77-84.
37. Vegran, F., R. Boidot, C. Oudin, J.M. Riedinger, and S. Lizard-Nacol, *Distinct expression of Survivin splice variants in breast carcinomas*. Int J Oncol, 2005. **27**(4): p. 1151-7.

38. Cheng, Z.J., L.H. Hu, W.R. Fu, and Q. Zhang, [*Expression of survivin and its splice variants in gastric cancer*]. *Zhonghua Bing Li Xue Za Zhi*, 2008. **37**(2): p. 130-1.
39. Boidot, R., F. Vegran, and S. Lizard-Nacol, *Predictive value of survivin alternative transcript expression in locally advanced breast cancer patients treated with neoadjuvant chemotherapy*. *Int J Mol Med*, 2009. **23**(2): p. 285-91.
40. Caldas, H., Y. Jiang, M.P. Holloway, J. Fangusaro, C. Mahotka, E.M. Conway, and R.A. Altura, *Survivin splice variants regulate the balance between proliferation and cell death*. *Oncogene*, 2005. **24**(12): p. 1994-2007.
41. Dohi, T., E. Beltrami, N.R. Wall, J. Plescia, and D.C. Altieri, *Mitochondrial survivin inhibits apoptosis and promotes tumorigenesis*. *J Clin Invest*, 2004. **114**(8): p. 1117-27.
42. Li, F. and X. Ling, *Survivin study: an update of "what is the next wave"?* *J Cell Physiol*, 2006. **208**(3): p. 476-86.
43. Song, Z. and M. Wu, *Identification of a novel nucleolar localization signal and a degradation signal in Survivin-deltaEx3: a potential link between nucleolus and protein degradation*. *Oncogene*, 2005. **24**(16): p. 2723-34.
44. Caldas, H., L.E. Honsey, and R.A. Altura, *Survivin 2alpha: a novel Survivin splice variant expressed in human malignancies*. *Mol Cancer*, 2005. **4**(1): p. 11.
45. Badran, A., A. Yoshida, K. Ishikawa, T. Goi, A. Yamaguchi, T. Ueda, and M. Inuzuka, *Identification of a novel splice variant of the human anti-apoptosis gene survivin*. *Biochem Biophys Res Commun*, 2004. **314**(3): p. 902-7.
46. Aggarwal, B.B., U. Bhardwaj, and Y. Takada, *Regulation of TRAIL-induced apoptosis by ectopic expression of antiapoptotic factors*. *Vitam Horm*, 2004. **67**: p. 453-83.
47. Li, P., D. Nijhawan, I. Budihardjo, S.M. Srinivasula, M. Ahmad, E.S. Alnemri, and X. Wang, *Cytochrome c and dATP-dependent formation of Apaf-1/caspase-9 complex initiates an apoptotic protease cascade*. *Cell*, 1997. **91**(4): p. 479-89.
48. Cain, K., *Chemical-induced apoptosis: formation of the Apaf-1 apoptosome*. *Drug Metab Rev*, 2003. **35**(4): p. 337-63.
49. Zou, H., W.J. Henzel, X. Liu, A. Lutschg, and X. Wang, *Apaf-1, a human protein homologous to C. elegans CED-4, participates in cytochrome c-dependent activation of caspase-3*. *Cell*, 1997. **90**(3): p. 405-13.
50. Cain, K., S.B. Bratton, and G.M. Cohen, *The Apaf-1 apoptosome: a large caspase-activating complex*. *Biochimie*, 2002. **84**(2-3): p. 203-14.
51. Oberst, A., C. Bender, and D.R. Green, *Living with death: the evolution of the mitochondrial pathway of apoptosis in animals*. *Cell Death Differ*, 2008. **15**(7): p. 1139-46.
52. Enari, M., H. Sakahira, H. Yokoyama, K. Okawa, A. Iwamatsu, and S. Nagata, *A caspase-activated DNase that degrades DNA during apoptosis, and its inhibitor ICAD*. *Nature*, 1998. **391**(6662): p. 43-50.

53. Conway, E.M., S. Pollefeyt, M. Steiner-Mosonyi, W. Luo, A. Devriese, F. Lupu, F. Bono, N. Leducq, F. Dol, P. Schaeffer, D. Collen, and J.M. Herbert, *Deficiency of survivin in transgenic mice exacerbates Fas-induced apoptosis via mitochondrial pathways*. Gastroenterology, 2002. **123**(2): p. 619-31.
54. Tamm, I., Y. Wang, E. Sausville, D.A. Scudiero, N. Vigna, T. Oltersdorf, and J.C. Reed, *IAP-family protein survivin inhibits caspase activity and apoptosis induced by Fas (CD95), Bax, caspases, and anticancer drugs*. Cancer Res, 1998. **58**(23): p. 5315-20.
55. Fornaro, M., J. Plescia, S. Chheang, G. Tallini, Y.M. Zhu, M. King, D.C. Altieri, and L.R. Languino, *Fibronectin protects prostate cancer cells from tumor necrosis factor-alpha-induced apoptosis via the AKT/survivin pathway*. J Biol Chem, 2003. **278**(50): p. 50402-11.
56. Colnaghi, R., C.M. Connell, R.M. Barrett, and S.P. Wheatley, *Separating the anti-apoptotic and mitotic roles of survivin*. J Biol Chem, 2006. **281**(44): p. 33450-6.
57. Knauer, S.K., O.H. Kramer, T. Knosel, K. Engels, F. Rodel, A.F. Kovacs, W. Dietmaier, L. Klein-Hitpass, N. Habtemichael, A. Schweitzer, J. Brieger, C. Rodel, W. Mann, I. Petersen, T. Heinzl, and R.H. Stauber, *Nuclear export is essential for the tumor-promoting activity of survivin*. FASEB J, 2007. **21**(1): p. 207-16.
58. Mesri, M., N.R. Wall, J. Li, R.W. Kim, and D.C. Altieri, *Cancer gene therapy using a survivin mutant adenovirus*. J Clin Invest, 2001. **108**(7): p. 981-90.
59. Blanc-Brude, O.P., M. Mesri, N.R. Wall, J. Plescia, T. Dohi, and D.C. Altieri, *Therapeutic targeting of the survivin pathway in cancer: initiation of mitochondrial apoptosis and suppression of tumor-associated angiogenesis*. Clin Cancer Res, 2003. **9**(7): p. 2683-92.
60. McKay, T.R., S. Bell, T. Tenev, V. Stoll, R. Lopes, N.R. Lemoine, and I.A. McNeish, *Procaspase 3 expression in ovarian carcinoma cells increases survivin transcription which can be countered with a dominant-negative mutant, survivin T34A; a combination gene therapy strategy*. Oncogene, 2003. **22**(23): p. 3539-47.
61. Wang, Z., S. Fukuda, and L.M. Pelus, *Survivin regulates the p53 tumor suppressor gene family*. Oncogene, 2004. **23**(49): p. 8146-53.
62. Fukuda, S. and L.M. Pelus, *Activated H-Ras regulates hematopoietic cell survival by modulating Survivin*. Biochem Biophys Res Commun, 2004. **323**(2): p. 636-44.
63. Suzuki, A., M. Hayashida, T. Ito, H. Kawano, T. Nakano, M. Miura, K. Akahane, and K. Shiraki, *Survivin initiates cell cycle entry by the competitive interaction with Cdk4/p16(INK4a) and Cdk2/cyclin E complex activation*. Oncogene, 2000. **19**(29): p. 3225-34.
64. Jeyaprakash, A.A., U.R. Klein, D. Lindner, J. Ebert, E.A. Nigg, and E. Conti, *Structure of a Survivin-Borealin-INCENP core complex reveals how chromosomal passengers travel together*. Cell, 2007. **131**(2): p. 271-85.

65. Vagnarelli, P. and W.C. Earnshaw, *Chromosomal passengers: the four-dimensional regulation of mitotic events*. Chromosoma, 2004. **113**(5): p. 211-22.
66. Tanaka, T.U., *Chromosome bi-orientation on the mitotic spindle*. Philos Trans R Soc Lond B Biol Sci, 2005. **360**(1455): p. 581-9.
67. Gassmann, R., A. Carvalho, A.J. Henzing, S. Ruchaud, D.F. Hudson, R. Honda, E.A. Nigg, D.L. Gerloff, and W.C. Earnshaw, *Borealin: a novel chromosomal passenger required for stability of the bipolar mitotic spindle*. J Cell Biol, 2004. **166**(2): p. 179-91.
68. Sampath, S.C., R. Ohi, O. Leisemann, A. Salic, A. Pozniakovski, and H. Funabiki, *The chromosomal passenger complex is required for chromatin-induced microtubule stabilization and spindle assembly*. Cell, 2004. **118**(2): p. 187-202.
69. Yang, D., A. Welm, and J.M. Bishop, *Cell division and cell survival in the absence of survivin*. Proc Natl Acad Sci U S A, 2004. **101**(42): p. 15100-5.
70. Castedo, M. and G. Kroemer, [*Mitotic catastrophe: a special case of apoptosis*]. J Soc Biol, 2004. **198**(2): p. 97-103.
71. Mansilla, S., W. Priebe, and J. Portugal, *Mitotic catastrophe results in cell death by caspase-dependent and caspase-independent mechanisms*. Cell Cycle, 2006. **5**(1): p. 53-60.
72. Vakifahmetoglu, H., M. Olsson, C. Tamm, N. Heidari, S. Orrenius, and B. Zhivotovsky, *DNA damage induces two distinct modes of cell death in ovarian carcinomas*. Cell Death Differ, 2008. **15**(3): p. 555-66.
73. Fukuda, S. and L.M. Pelus, *Elevation of Survivin levels by hematopoietic growth factors occurs in quiescent CD34+ hematopoietic stem and progenitor cells before cell cycle entry*. Cell Cycle, 2002. **1**(5): p. 322-6.
74. Fukuda, S., C.R. Mantel, and L.M. Pelus, *Survivin regulates hematopoietic progenitor cell proliferation through p21WAF1/Cip1-dependent and -independent pathways*. Blood, 2004. **103**(1): p. 120-7.
75. Janzen, V., H.E. Fleming, T. Riedt, G. Karlsson, M.J. Riese, C. Lo Celso, G. Reynolds, C.D. Milne, C.J. Paige, S. Karlsson, M. Woo, and D.T. Scadden, *Hematopoietic stem cell responsiveness to exogenous signals is limited by caspase-3*. Cell Stem Cell, 2008. **2**(6): p. 584-94.
76. Fukuda, S. and L.M. Pelus, *Survivin, a cancer target with an emerging role in normal adult tissues*. Mol Cancer Ther, 2006. **5**(5): p. 1087-98.
77. Peng, X.C., L. Yang, L.P. Yang, Y.Q. Mao, H.S. Yang, J.Y. Liu, D.M. Zhang, L.J. Chen, and Y.Q. Wei, *Efficient inhibition of murine breast cancer growth and metastasis by gene transferred mouse survivin Thr34-->Ala mutant*. J Exp Clin Cancer Res, 2008. **27**: p. 46.
78. Ogura, A., Y. Watanabe, D. Iizuka, H. Yasui, M. Amitani, S. Kobayashi, M. Kuwabara, and O. Inanami, *Radiation-induced apoptosis of tumor cells is facilitated by inhibition of the interaction between Survivin and Smac/DIABLO*. Cancer Lett, 2008. **259**(1): p. 71-81.

79. Ma, X., W. Zheng, D. Wei, Y. Ma, T. Wang, J. Wang, Q. Liu, and S. Yang, *High-level expression, purification and pro-apoptosis activity of HIV-TAT-survivin (T34A) mutant to cancer cells in vitro*. J Biotechnol, 2006. **123**(3): p. 367-78.
80. Yan, H., J. Thomas, T. Liu, D. Raj, N. London, T. Tandeski, S.A. Leachman, R.M. Lee, and D. Grossman, *Induction of melanoma cell apoptosis and inhibition of tumor growth using a cell-permeable Survivin antagonist*. Oncogene, 2006. **25**(52): p. 6968-74.
81. Zhang, M., N. Mukherjee, R.S. Bermudez, D.E. Latham, M.A. Delaney, A.L. Zietman, W.U. Shipley, and A. Chakravarti, *Adenovirus-mediated inhibition of survivin expression sensitizes human prostate cancer cells to paclitaxel in vitro and in vivo*. Prostate, 2005. **64**(3): p. 293-302.
82. Whitesell, L., E.G. Mimnaugh, B. De Costa, C.E. Myers, and L.M. Neckers, *Inhibition of heat shock protein HSP90-pp60v-src heteroprotein complex formation by benzoquinone ansamycins: essential role for stress proteins in oncogenic transformation*. Proc Natl Acad Sci U S A, 1994. **91**(18): p. 8324-8.
83. Meli, M., M. Pennati, M. Curto, M.G. Daidone, J. Plescia, S. Toba, D.C. Altieri, N. Zaffaroni, and G. Colombo, *Small-molecule targeting of heat shock protein 90 chaperone function: rational identification of a new anticancer lead*. J Med Chem, 2006. **49**(26): p. 7721-30.
84. Sharp, S. and P. Workman, *Inhibitors of the HSP90 molecular chaperone: current status*. Adv Cancer Res, 2006. **95**: p. 323-48.
85. Prodromou, C., S.M. Roe, R. O'Brien, J.E. Ladbury, P.W. Piper, and L.H. Pearl, *Identification and structural characterization of the ATP/ADP-binding site in the Hsp90 molecular chaperone*. Cell, 1997. **90**(1): p. 65-75.
86. Schulte, T.W. and L.M. Neckers, *The benzoquinone ansamycin 17-allylamino-17-demethoxygeldanamycin binds to HSP90 and shares important biologic activities with geldanamycin*. Cancer Chemother Pharmacol, 1998. **42**(4): p. 273-9.
87. Hostein, I., D. Robertson, F. DiStefano, P. Workman, and P.A. Clarke, *Inhibition of signal transduction by the Hsp90 inhibitor 17-allylamino-17-demethoxygeldanamycin results in cytostasis and apoptosis*. Cancer Res, 2001. **61**(10): p. 4003-9.
88. Weissman, I.L. and J.A. Shizuru, *The origins of the identification and isolation of hematopoietic stem cells, and their capability to induce donor-specific transplantation tolerance and treat autoimmune diseases*. Blood, 2008. **112**(9): p. 3543-53.
89. Shaheen, M.a.B., H.E., *Chapter 19: The humoral regulation of hematopoiesis*. 4th ed. Hematology: Basic Principles and Practice, ed. R. Ed. Hoffman, Benz E, Shattil S, Furie B, Cohen H, Silberstein L and McGlave P. 2005: Elsevier Churchill Livingstone.
90. Berenson, R.J., R.G. Andrews, W.I. Bensinger, D. Kalamasz, G. Knitter, C.D. Buckner, and I.D. Bernstein, *Antigen CD34+ marrow cells engraft lethally irradiated baboons*. J Clin Invest, 1988. **81**(3): p. 951-5.

91. Terstappen, L.W., S. Huang, M. Safford, P.M. Lansdorp, and M.R. Loken, *Sequential generations of hematopoietic colonies derived from single nonlineage-committed CD34+CD38- progenitor cells*. Blood, 1991. **77**(6): p. 1218-27.
92. Thornley, I., D.R. Sutherland, R. Nayar, L. Sung, M.H. Freedman, and H.A. Messner, *Replicative stress after allogeneic bone marrow transplantation: changes in cycling of CD34+CD90+ and CD34+CD90- hematopoietic progenitors*. Blood, 2001. **97**(6): p. 1876-8.
93. Fritsch, G., P. Buchinger, D. Printz, F.M. Fink, G. Mann, C. Peters, T. Wagner, A. Adler, and H. Gadner, *Rapid discrimination of early CD34+ myeloid progenitors using CD45-RA analysis*. Blood, 1993. **81**(9): p. 2301-9.
94. Kiel, M.J., O.H. Yilmaz, T. Iwashita, C. Terhorst, and S.J. Morrison, *SLAM family receptors distinguish hematopoietic stem and progenitor cells and reveal endothelial niches for stem cells*. Cell, 2005. **121**(7): p. 1109-21.
95. Strausfeld, U., J.C. Labbe, D. Fesquet, J.C. Cavadore, A. Picard, K. Sadhu, P. Russell, and M. Doree, *Dephosphorylation and activation of a p34cdc2/cyclin B complex in vitro by human CDC25 protein*. Nature, 1991. **351**(6323): p. 242-5.
96. Castedo, M., J.L. Perfettini, T. Roumier, and G. Kroemer, *Cyclin-dependent kinase-1: linking apoptosis to cell cycle and mitotic catastrophe*. Cell Death Differ, 2002. **9**(12): p. 1287-93.
97. Blangy, A., H.A. Lane, P. d'Herin, M. Harper, M. Kress, and E.A. Nigg, *Phosphorylation by p34cdc2 regulates spindle association of human Eg5, a kinesin-related motor essential for bipolar spindle formation in vivo*. Cell, 1995. **83**(7): p. 1159-69.
98. Peter, M., J. Nakagawa, M. Doree, J.C. Labbe, and E.A. Nigg, *In vitro disassembly of the nuclear lamina and M phase-specific phosphorylation of lamins by cdc2 kinase*. Cell, 1990. **61**(4): p. 591-602.
99. Kimura, K., M. Hirano, R. Kobayashi, and T. Hirano, *Phosphorylation and activation of 13S condensin by Cdc2 in vitro*. Science, 1998. **282**(5388): p. 487-90.
100. Smits, V.A. and R.H. Medema, *Checking out the G(2)/M transition*. Biochim Biophys Acta, 2001. **1519**(1-2): p. 1-12.
101. Peters, J.M., *The anaphase-promoting complex: proteolysis in mitosis and beyond*. Mol Cell, 2002. **9**(5): p. 931-43.
102. Nigg, E.A., *Mitotic kinases as regulators of cell division and its checkpoints*. Nat Rev Mol Cell Biol, 2001. **2**(1): p. 21-32.
103. Rudner, A.D. and A.W. Murray, *Phosphorylation by Cdc28 activates the Cdc20-dependent activity of the anaphase-promoting complex*. J Cell Biol, 2000. **149**(7): p. 1377-90.
104. Heald, R., M. McLoughlin, and F. McKeon, *Human wee1 maintains mitotic timing by protecting the nucleus from cytoplasmically activated Cdc2 kinase*. Cell, 1993. **74**(3): p. 463-74.

105. Fotedar, R., J. Flatt, S. Gupta, R.L. Margolis, P. Fitzgerald, H. Messier, and A. Fotedar, *Activation-induced T-cell death is cell cycle dependent and regulated by cyclin B*. Mol Cell Biol, 1995. **15**(2): p. 932-42.
106. Jin, P., S. Hardy, and D.O. Morgan, *Nuclear localization of cyclin B1 controls mitotic entry after DNA damage*. J Cell Biol, 1998. **141**(4): p. 875-85.
107. Porter, L.A., I.H. Cukier, and J.M. Lee, *Nuclear localization of cyclin B1 regulates DNA damage-induced apoptosis*. Blood, 2003. **101**(5): p. 1928-33.
108. Castedo, M., K.F. Ferri, J. Blanco, T. Roumier, N. Larochette, J. Barretina, A. Amendola, R. Nardacci, D. Metivier, J.A. Este, M. Piacentini, and G. Kroemer, *Human immunodeficiency virus 1 envelope glycoprotein complex-induced apoptosis involves mammalian target of rapamycin/FKBP12-rapamycin-associated protein-mediated p53 phosphorylation*. J Exp Med, 2001. **194**(8): p. 1097-110.
109. Freeman, R.S., S. Estus, and E.M. Johnson, Jr., *Analysis of cell cycle-related gene expression in postmitotic neurons: selective induction of Cyclin D1 during programmed cell death*. Neuron, 1994. **12**(2): p. 343-55.
110. Oberhammer, F.A., K. Hochegger, G. Froschl, R. Tiefenbacher, and M. Pavelka, *Chromatin condensation during apoptosis is accompanied by degradation of lamin A+B, without enhanced activation of cdc2 kinase*. J Cell Biol, 1994. **126**(4): p. 827-37.
111. Norbury, C., M. MacFarlane, H. Fearnhead, and G.M. Cohen, *Cdc2 activation is not required for thymocyte apoptosis*. Biochem Biophys Res Commun, 1994. **202**(3): p. 1400-6.
112. Perry, M.E. and A.J. Levine, *Tumor-suppressor p53 and the cell cycle*. Curr Opin Genet Dev, 1993. **3**(1): p. 50-4.
113. Alberts, B., Johnson, A., Lewis J., Raff M., Roberts K. and Walter, P., *Molecular Biology of the Cell*. 4th ed. 2002, New York.
114. Wang, Y., S.J. Decker, and J. Sebolt-Leopold, *Knockdown of Chk1, Wee1 and Myt1 by RNA interference abrogates G2 checkpoint and induces apoptosis*. Cancer Biol Ther, 2004. **3**(3): p. 305-13.
115. Castedo, M., J.L. Perfettini, T. Roumier, K. Andreau, R. Medema, and G. Kroemer, *Cell death by mitotic catastrophe: a molecular definition*. Oncogene, 2004. **23**(16): p. 2825-37.
116. Viktorsson, K., R. Lewensohn, and B. Zhivotovsky, *Apoptotic pathways and therapy resistance in human malignancies*. Adv Cancer Res, 2005. **94**: p. 143-96.
117. Ellis, H.M. and H.R. Horvitz, *Genetic control of programmed cell death in the nematode C. elegans*. Cell, 1986. **44**(6): p. 817-29.
118. Hengartner, M.O., R.E. Ellis, and H.R. Horvitz, *Caenorhabditis elegans gene ced-9 protects cells from programmed cell death*. Nature, 1992. **356**(6369): p. 494-9.
119. Miura, M., H. Zhu, R. Rotello, E.A. Hartwig, and J. Yuan, *Induction of apoptosis in fibroblasts by IL-1 beta-converting enzyme, a mammalian homolog of the C. elegans cell death gene ced-3*. Cell, 1993. **75**(4): p. 653-60.

120. Fritz, J.H., R.L. Ferrero, D.J. Philpott, and S.E. Girardin, *Nod-like proteins in immunity, inflammation and disease*. Nat Immunol, 2006. **7**(12): p. 1250-7.
121. Gross, A., J.M. McDonnell, and S.J. Korsmeyer, *BCL-2 family members and the mitochondria in apoptosis*. Genes Dev, 1999. **13**(15): p. 1899-911.
122. Li, J. and J. Yuan, *Caspases in apoptosis and beyond*. Oncogene, 2008. **27**(48): p. 6194-206.
123. Qin, H., S.M. Srinivasula, G. Wu, T. Fernandes-Alnemri, E.S. Alnemri, and Y. Shi, *Structural basis of procaspase-9 recruitment by the apoptotic protease-activating factor 1*. Nature, 1999. **399**(6736): p. 549-57.
124. Cardone, M.H., N. Roy, H.R. Stennicke, G.S. Salvesen, T.F. Franke, E. Stanbridge, S. Frisch, and J.C. Reed, *Regulation of cell death protease caspase-9 by phosphorylation*. Science, 1998. **282**(5392): p. 1318-21.
125. Allan, L.A., N. Morrice, S. Brady, G. Magee, S. Pathak, and P.R. Clarke, *Inhibition of caspase-9 through phosphorylation at Thr 125 by ERK MAPK*. Nat Cell Biol, 2003. **5**(7): p. 647-54.
126. Allan, L.A. and P.R. Clarke, *Phosphorylation of caspase-9 by CDK1/cyclin B1 protects mitotic cells against apoptosis*. Mol Cell, 2007. **26**(2): p. 301-10.
127. Lakhani, S.A., A. Masud, K. Kuida, G.A. Porter, Jr., C.J. Booth, W.Z. Mehal, I. Inayat, and R.A. Flavell, *Caspases 3 and 7: key mediators of mitochondrial events of apoptosis*. Science, 2006. **311**(5762): p. 847-51.
128. Takizawa, C.G. and D.O. Morgan, *Control of mitosis by changes in the subcellular location of cyclin-B1-Cdk1 and Cdc25C*. Curr Opin Cell Biol, 2000. **12**(6): p. 658-65.
129. Kellogg, D.R., *Wee1-dependent mechanisms required for coordination of cell growth and cell division*. J Cell Sci, 2003. **116**(Pt 24): p. 4883-90.
130. Lei, P., Y. He, W. Shi, J. Peng, S. Wu, H. Zhu, J. Chen, and G. Shen, *Effect of human WEE1 and stem cell factor on human CD34+ umbilical cord blood cell damage induced by chemotherapeutic agents*. Acta Biochim Biophys Sin (Shanghai), 2007. **39**(8): p. 599-607.
131. Chen, G., L. Shi, D.W. Litchfield, and A.H. Greenberg, *Rescue from granzyme B-induced apoptosis by Wee1 kinase*. J Exp Med, 1995. **181**(6): p. 2295-300.
132. Yuan, H., Y.M. Xie, and I.S. Chen, *Depletion of Wee-1 kinase is necessary for both human immunodeficiency virus type 1 Vpr- and gamma irradiation-induced apoptosis*. J Virol, 2003. **77**(3): p. 2063-70.
133. Smith, J.J., D.A. Richardson, J. Kopf, M. Yoshida, R.E. Hollingsworth, and S. Kornbluth, *Apoptotic regulation by the Crk adapter protein mediated by interactions with Wee1 and Crm1/exportin*. Mol Cell Biol, 2002. **22**(5): p. 1412-23.
134. Fukuda, S., R.G. Foster, S.B. Porter, and L.M. Pelus, *The antiapoptosis protein survivin is associated with cell cycle entry of normal cord blood CD34(+) cells and modulates cell cycle and proliferation of mouse hematopoietic progenitor cells*. Blood, 2002. **100**(7): p. 2463-71.

135. Janicke, R.U., M.L. Sprengart, M.R. Wati, and A.G. Porter, *Caspase-3 is required for DNA fragmentation and morphological changes associated with apoptosis*. J Biol Chem, 1998. **273**(16): p. 9357-60.
136. Panvichian, R., K. Orth, M.L. Day, K.C. Day, M.J. Pilat, and K.J. Pienta, *Paclitaxel-associated multiminucleation is permitted by the inhibition of caspase activation: a potential early step in drug resistance*. Cancer Res, 1998. **58**(20): p. 4667-72.
137. Shi, L., W.K. Nishioka, J. Th'ng, E.M. Bradbury, D.W. Litchfield, and A.H. Greenberg, *Premature p34cdc2 activation required for apoptosis*. Science, 1994. **263**(5150): p. 1143-5.
138. Yao, S.L., K.A. McKenna, S.J. Sharkis, and A. Bedi, *Requirement of p34cdc2 kinase for apoptosis mediated by the Fas/APO-1 receptor and interleukin 1beta-converting enzyme-related proteases*. Cancer Res, 1996. **56**(20): p. 4551-5.
139. Shi, L., G. Chen, D. He, D.G. Bosc, D.W. Litchfield, and A.H. Greenberg, *Granzyme B induces apoptosis and cyclin A-associated cyclin-dependent kinase activity in all stages of the cell cycle*. J Immunol, 1996. **157**(6): p. 2381-5.
140. Meikrantz, W., S. Gisselbrecht, S.W. Tam, and R. Schlegel, *Activation of cyclin A-dependent protein kinases during apoptosis*. Proc Natl Acad Sci U S A, 1994. **91**(9): p. 3754-8.
141. Fukuda, S., P. Singh, A. Moh, M. Abe, E.M. Conway, H.S. Boswell, S. Yamaguchi, X.Y. Fu, and L.M. Pelus, *Survivin mediates aberrant hematopoietic progenitor cell proliferation and acute leukemia in mice induced by internal-tandem-duplication of Flt3*. Blood, 2009.
142. Kelly, L.M., Q. Liu, J.L. Kutok, I.R. Williams, C.L. Boulton, and D.G. Gilliland, *FLT3 internal tandem duplication mutations associated with human acute myeloid leukemias induce myeloproliferative disease in a murine bone marrow transplant model*. Blood, 2002. **99**(1): p. 310-8.
143. Zhou, B.B., H. Li, J. Yuan, and M.W. Kirschner, *Caspase-dependent activation of cyclin-dependent kinases during Fas-induced apoptosis in Jurkat cells*. Proc Natl Acad Sci U S A, 1998. **95**(12): p. 6785-90.
144. Alam, A., L.Y. Cohen, S. Aouad, and R.P. Sekaly, *Early activation of caspases during T lymphocyte stimulation results in selective substrate cleavage in nonapoptotic cells*. J Exp Med, 1999. **190**(12): p. 1879-90.
145. Plescia, J., W. Salz, F. Xia, M. Pennati, N. Zaffaroni, M.G. Daidone, M. Meli, T. Dohi, P. Fortugno, Y. Nefedova, D.I. Gabrilovich, G. Colombo, and D.C. Altieri, *Rational design of shepherdin, a novel anticancer agent*. Cancer Cell, 2005. **7**(5): p. 457-68.
146. Chandele, A., V. Prasad, J.C. Jagtap, R. Shukla, and P.R. Shastri, *Upregulation of survivin in G2/M cells and inhibition of caspase 9 activity enhances resistance in staurosporine-induced apoptosis*. Neoplasia, 2004. **6**(1): p. 29-40.

147. Jones, M.K., O.R. Padilla, N.A. Webb, and M. Norng, *The anti-apoptosis protein, survivin, mediates gastric epithelial cell cytoprotection against ethanol-induced injury via activation of the p34(cdc2) cyclin-dependent kinase*. J Cell Physiol, 2008. **215**(3): p. 750-64.
148. Banks, D.P., J. Plescia, D.C. Altieri, J. Chen, S.H. Rosenberg, H. Zhang, and S.C. Ng, *Survivin does not inhibit caspase-3 activity*. Blood, 2000. **96**(12): p. 4002-3.
149. Li, C., Z. Wu, M. Liu, M. Pazgier, and W. Lu, *Chemically synthesized human survivin does not inhibit caspase-3*. Protein Sci, 2008.
150. Wright, M.E., D.K. Han, and D.M. Hockenbery, *Caspase-3 and inhibitor of apoptosis protein(s) interactions in Saccharomyces cerevisiae and mammalian cells*. FEBS Lett, 2000. **481**(1): p. 13-8.
151. Shin, S., B.J. Sung, Y.S. Cho, H.J. Kim, N.C. Ha, J.I. Hwang, C.W. Chung, Y.K. Jung, and B.H. Oh, *An anti-apoptotic protein human survivin is a direct inhibitor of caspase-3 and -7*. Biochemistry, 2001. **40**(4): p. 1117-23.
152. Tewari, M., L.T. Quan, K. O'Rourke, S. Desnoyers, Z. Zeng, D.R. Beidler, G.G. Poirier, G.S. Salvesen, and V.M. Dixit, *Yama/ CPP32 beta, a mammalian homolog of CED-3, is a CrmA-inhibitable protease that cleaves the death substrate poly(ADP-ribose) polymerase*. Cell, 1995. **81**(5): p. 801-9.
153. Leach, S.D., C.D. Scatena, C.J. Keefer, H.A. Goodman, S.Y. Song, L. Yang, and J.A. Pietsenpol, *Negative regulation of Wee1 expression and Cdc2 phosphorylation during p53-mediated growth arrest and apoptosis*. Cancer Res, 1998. **58**(15): p. 3231-6.
154. Wang, F., Y. Zhu, Y. Huang, S. McAvoy, W.B. Johnson, T.H. Cheung, T.K. Chung, K.W. Lo, S.F. Yim, M.M. Yu, H.Y. Ngan, Y.F. Wong, and D.I. Smith, *Transcriptional repression of WEE1 by Kruppel-like factor 2 is involved in DNA damage-induced apoptosis*. Oncogene, 2005. **24**(24): p. 3875-85.
155. Satyanarayana, A., M.B. Hilton, and P. Kaldis, *p21 Inhibits Cdk1 in the Absence of Cdk2 to Maintain the G1/S Phase DNA Damage Checkpoint*. Mol Biol Cell, 2008. **19**(1): p. 65-77.
156. Gervais, J.L., P. Seth, and H. Zhang, *Cleavage of CDK inhibitor p21(Cip1/Waf1) by caspases is an early event during DNA damage-induced apoptosis*. J Biol Chem, 1998. **273**(30): p. 19207-12.

CURRICULUM VITAE

Javier Rivera Guzmán

Education:

Ph.D. Microbiology & Immunology, August 2009

Indiana University, earned at Indiana University-Purdue University at Indianapolis

B.Sc. Biology, May 2002

Inter American University of Puerto Rico, San German, Puerto Rico

Research and Training Experience:

Indiana University School of Medicine, September 2006 to August 2009

Graduate Student, Department of Microbiology & Immunology

Research focus: investigation of the cross-regulatory loop between Survivin and the p34^{Cdc2} kinase, specifically within hematopoietic cells.

Indiana University School of Medicine, March 2003 to September 2006

Graduate Student, Department of Microbiology & Immunology

Research focus: investigation of prostate cancer progression due to two essential factors, Early Growth Response 1 protein (Egr-1) and the transcription factor and serine transmembrane protease Hepsin. Specifically evaluated the transactivation of Hepsin via Egr-1 and its effect on prostate cancer cellular growth.

Indiana University Purdue University Indianapolis (IUPUI) Summer Research Opportunities Program, June 2002 to August 2002

Fellow, Indiana University School of Medicine-Department of Infectious Diseases.

Research focus: attempting to elucidate the function of the HPV E1^{E4} protein by creating a GFP-E1^{E4} fusion protein, transfecting it into NIK cells and determining its intracellular localization.

Inter American University of Puerto Rico, June 2001 to May 2002

Undergraduate McNair Scholar

Research focus: field research with Robin Walker, M.Sc., in the Guánica Dry Forest International Biosphere studying throughfall and stemflow nutrient cycling in this ecosystem.

Publications:

Rivera Guzman J, Fukuda S and Pelus LM. 2009. Inhibition of caspase-3 by Survivin Prevents Wee1 Kinase Degradation and Promotes Cell Survival by Maintaining Phosphorylation of p34Cdc2. Manuscript Accepted with Minor Revision.

Mayo LD, Rok Seo Y, Jackson MW, Smith ML, Rivera Guzman J, Korgaonkar CK, Donner DB. 2005. Phosphorylation of human p53 at serine 46 determines promoter selection and whether apoptosis is attenuated or amplified. *Journal of Biological Chemistry* 280(28):25953-9.

Gustin JA, Ozes ON, Akca H, Pincheira R, Mayo L, Li Q, Rivera Guzman J, Korgaonkar CK, Donner DB. 2004. Cell type specific expression of the I κ B kinases determines the significance of PI 3-kinase/Akt signaling to NF- κ B activation. *Journal of Biological Chemistry* 279(3):1615-20.

Conferences Attended:

November 2008, ABRCMS (Annual Biomedical Research Conference for Minority Students), Indiana University recruitment officer, Orlando, FL

June 2008, AGEP Colloquim Postdoctoral Bootcamp, San Francisco, CA

Rivera Guzman J., Fukuda S. and Pelus L.M. 2007. Survivin Inhibition of p34Cdc2 Via Protection of Wee1 Correlates with Survival. *Blood* 110(11), ASH Meeting Supplement: p.984A. Abstract Published. Poster presented at the American Society of Experimental Hematology (ASH) annual meeting, December 7-11 in Atlanta, GA

Rivera Guzman J., Fukuda S. and Pelus L.M. 2007. Survival Crosstalk: Survivin Inhibition of p34Cdc2. Poster and oral presentations at the St Jude Childrens Research Hospital National Graduate Student Symposium meeting in Memphis, Tennessee
Rivera Guzman J., Fukuda S. and Pelus L.M. 2006. Survivin Increases Inhibition of p34Cdc2 – Another Putative Anti-Apoptotic Mechanism. *Experimental Hematology* 34(9), Supplement 1: p81. Abstract Published. Poster presented at the International Society of Experimental Hematology (ISEH) meeting, September 2006 in Minneapolis, MN

June 2005, Preparing Future Faculty STEM Summer Institute Conference, El Paso, TX

November 2004, Autumn Immunology Conference, Chicago, CA

October 2004, 57th Annual Symposium on Fundamental Cancer Research, Houston, TX

April 2004, American Association for Higher Education Conference, San Diego, CA

August 2002, Summer Research Opportunities Program Research Conference, Penn State University, College Park, PA

November 25, 2001 to December 2, 2001, 4th International Symposium of Sustainable Development in the Andes, Merida, Venezuela

Honors, Awards and Fellowships:

IU Nominee and Selected Attendee, Summer AGEP Colloquium Postdoctoral Bootcamp, June 2008 University of California San Francisco

St Jude Children's Research Hospital Fellowship, National Graduate Student Symposium, March 2007 Memphis, TN

Selected Abstract Travel Award, International Society of Experimental Hematology Conference, September 2006, Minneapolis, MN

John Wallace Minority Travel Scholarship, Autumn Immunology Conference, November 2004 Chicago, IL

Gene Therapy Training Grant, Indiana University School of Medicine NIH pre-Doctoral Fellow, T32 from NHLBI (HL007910), July 2004 to June 2009
Conference and Travel Award, American Association for Higher Education Hispanic Caucus Conference Fellow, April 2004, San Diego, CA

NIH pre-Doctoral Fellow, T32 from NIDDK, Hematopoiesis Training Program, July 2003 to June 2004, Indiana University School of Medicine, Indianapolis, IN

Graduated Ronald E. McNair Scholar, McNair Scholars Program, Inter American University of Puerto Rico, San German, PR

Graduated Magna Cum Laude, Inter American University of Puerto Rico, San German, PR

1st Place Oral Presentations, Ronald E. McNair Summer Training Program Forum, August 2001, Inter American University of Puerto Rico

Professional Experience:

Preparing Future Faculty Institute, Indiana University-Purdue University Indianapolis.
Full-day seminar series on faculty preparation and duties, June 2008

Ad hoc member (Senior Graduate Student), Advisory Committee
NIH NIGMS 1R25 GM079657-01 (Hal Broxmeyer, PI), Indiana University School of
Medicine Initiative for Maximizing Graduate Student Diversity, January 2007
Indianapolis, IN

Indiana University School of Medicine, Indianapolis, IN- June 2006 to July 2006
Instructor-Medical Spanish for Medical Students
Planned lessons, created teaching materials, and coordinated an interactive clinical
scenario simulation review session.

President, IUPUI Under-represented Professional and Graduate student Organization
(UPNGO), January 2006 to August 2006, Indianapolis, IN

Preparing Future Faculty STEM Summer Institute Conference at the University of Texas
at El Paso, June 2005

Indiana University Department of Microbiology & Immunology, Indianapolis, IN-
January 2004-May 2004
Teaching Assistant-Medical Microbiology for the Nursing Program
Taught one lab section; helped proctor and grade lecture exams.

President of the $\zeta\beta$ Chapter of the $\beta\beta\beta$ Biological Honor Society, August 2001 to May
2002, Inter American University of Puerto Rico

Vice-President of the $\zeta\beta$ Chapter of the $\beta\beta\beta$ Biological Honor Society, January 2001 to
July 2001, Inter American University of Puerto Rico