

EVALUATION OF FRACTURE RESISTANCE OF THREE POST AND CORE  
SYSTEMS IN ENDODONTICALLY TREATED TEETH UNDER  
LOADING TO FAILURE; AND MARGINAL GAP  
MEASUREMENT BEFORE AND AFTER  
CYCLIC LOADING

by

Amir N. Saad

Submitted to the Graduate Faculty of the School of Dentistry in partial fulfillment of the requirements for the degree of Master of Science in Dentistry, Indiana University School of Dentistry, 2009.

Thesis accepted by the faculty of the Department of Restorative Dentistry,  
Indiana University School of Dentistry, in partial fulfillment of the requirements for  
the degree of Master of Science in Dentistry.

---

Thomas R. Katona

---

Carl J. Andres

---

Bruce A. Matis

---

Jeffrey A. Platt  
Chair of Research Committee

---

John A. Levon  
Program Director

Date \_\_\_\_\_

DEDICATION

To my parents, Nabil and Vivianne.

## ACKNOWLEDGMENTS

I am very thankful to all of my committee members for making this project possible.

Sincere thanks are extended to Dr. Jeffrey Platt, chairman of the Dental Materials Department, who was always willing to listen, talk, and give positive feedback with continued support to complete this research project.

I am deeply thankful to Dr. Thomas Katona for helping me to use the machines to test my pilot and study samples.

I am grateful to Dr. John Levon for his supervision, support, and encouragement to make this thesis possible.

I am also grateful to Dr. Carl Andres for his constant interest, feedback, guidance, and cooperation.

I am very thankful to Dr. Bruce Matis for his constant uplifting spirit, and positive feedback.

I am thankful to Dr. David Brown for his guidance, help, and support in making this thesis possible.

I am also thankful to Miss Meaghan MacPherson; she was always there when I needed help in the Dental Materials lab.

I am grateful to Mr. George Eckert for his help in compiling the statistics in this study and his speed in handling my work.

I am also grateful to Dr. Thongthammachat for presenting a study that was my guide for more research in the field of prosthodontics. I am also grateful to Dr. Elena D. Valadez for her thesis as a guide for my final revisions. A special thank-you to all my classmates and friends for their continuous help and support in the Graduate

Prosthodontics department lab, and a special thank-you to my dear friend, Dr. Emad Estefanous, for his encouragement for me to enroll in this great program.

I would also like to thank Coltene Whaledent, SybronEndo, and Kerr Dental for supplying me with the necessary materials and equipment to carry out my project.

Finally, I dedicate this thesis to my parents. Thank you for your constant support, love, and encouragement for me to complete this master's program and make this thesis possible.

TABLE OF CONTENTS



Introduction.....	1
Review of Literature.....	4
Materials and Methods.....	19
Results.....	29
Tables and Figures.....	37
Discussion.....	65
Summary and Conclusions.....	74
References.....	76
Appendixes.....	91
Abstract.....	99
Curriculum Vitae	

LIST OF ILLUSTRATIONS

TABLE I	Post systems tested.....	38
TABLE II	Type of post systems, number of specimens, and type of testing...	39
TABLE III	Maximum load-to-failure (Newtons).....	40
TABLE IV	Moment of inertia (mm <sup>4</sup> ).....	41
TABLE V	Facial marginal gap (µm).....	42
TABLE VI	Lingual marginal gap (µm).....	43
TABLE VII	Average marginal gap — facial and lingual (µm).....	44
FIGURE 1	Load-to-failure group CP.....	45
FIGURE 2	Fatigue-loading CP group.....	46
FIGURE 3	Load-to-failure FR group.....	47
FIGURE 4	Fatigue loading FR group.....	48
FIGURE 5	Load-to-failure MR group.....	49
FIGURE 6	Fatigue-loading MR group.....	50
FIGURE 7	Load-to-failure sample.....	51
FIGURE 8	Fatigue-loading sample.....	52
FIGURE 9	Fatigue loading sample after testing; arrow indicates reverse pull at 135° to long axis of tooth .....	53
FIGURE 10	Facial view of fatigue-loading sample.....	54
FIGURE 11	Template for teeth reduction and coping wax-up.....	55
FIGURE 12	Composite core build-up using template.....	56
FIGURE 13	MTS Bionix 858 Test System machine with load-to-failure setup.	57
FIGURE 14	Tooth sample undergoing load-to-failure testing.....	58
FIGURE 15	MTS Bionix 858 Test System machine with fatigue-loading setup	59

FIGURE 16	Software showing fatigue loading forces and displacement.....	60
FIGURE 17	Specimen #29 demonstrated an unusually larger marginal gap before remaking of the coping.....	61
FIGURE 18	Load-to-failure sample from group CP showing apical fracture....	62
FIGURE 19	Load-to-failure sample from group FR showing junction of middle and apical thirds fracture.....	63
FIGURE 20	Load-to-failure sample from group MR showing middle third fracture.....	64
APPENDIX I	Group CP individual fatigue loading marginal gap data (microns)	92
APPENDIX II	Group FR individual fatigue loading marginal gap data (microns)	93
APPENDIX III	Group MR individual fatigue loading marginal gap data (microns).....	94
APPENDIX IV	Individual load-to-failure strength data of the post systems (Newtons).....	95
APPENDIX V	Group CP moment of inertia at cervical area ( I ) and fracture site ( I' ).....	96
APPENDIX VI	Group FR moment of inertia at cervical area ( I ) and fracture site ( I' ).....	97
APPENDIX VII	Group MR moment of inertia at cervical area ( I ) and fracture site ( I' ).....	98

## INTRODUCTION

The standard of care following endodontic treatment when a tooth lacks structure and vitality is to place a post and core build-up. The criteria used in restoring endodontically treated teeth have long been influenced by the feel, experience, and empiricism of the practitioner. The considerations before initiating endodontic treatment include an assessment of the ability to restore the tooth to form and function. If restoration is the decision, then the practitioner has a choice of post and core designs to retain an overlying crown. Extraction is the alternative.

The use of posts in nonvital teeth dates back more than three centuries.<sup>1</sup> The concept of posts or dowels was originally designed as a means of retention of the coronal restoration if inadequate tooth structure remained.<sup>2</sup> Posts were viewed as a method to reinforce nonvital teeth.<sup>3</sup> Several reports hypothesize that the rigidity of the post should be as close as possible to that of the root to distribute occlusal forces evenly along the length of the root.<sup>4,5</sup> Various post and core designs and materials have been developed. These include cast post and cores, metal prefabricated posts with a core build-up of composite resin, and fiber posts with a core build-up of composite resin. High noble alloys, base metal alloys, zircon and quartz fiber, carbon fiber, and glass fiber composites have been used as posts.

Post stiffness is important from a mechanical point of view. As the stiffness of a post increases, so does the risk of tooth fracture.<sup>6</sup> Even so, stiffer than vital or nonvital natural teeth, cast metals are very useful and long-lasting as the standard of care in treatment.

Fiber posts with a more natural color than metallic posts have been developed with an elastic modulus very similar to that of dentin. The similarity in elastic modulus to dentin may explain a reported lack of significant root fractures seen in natural teeth with the use of fiber posts.<sup>7</sup> Although the use of fiber posts is promising, their long-term success has not been evaluated.

Thus, the purpose of this study was to evaluate the fracture resistance of three post and core systems in endodontically treated teeth by loading to failure. Another purpose is to evaluate the marginal gap opening on teeth after cyclic loading.

## REVIEW OF LITERATURE



## HISTORY

Root canal treatment dates back to the 18<sup>th</sup> century, when F. Hoffman used hot wires for pulp cauterization.<sup>8,9</sup> In 1869, G.V. Black<sup>10</sup> introduced the idea of anchoring a crown to the root of a nonvital tooth via retentive principles. G.V. Black advocated filling the root canal with gold foil and anchoring a threaded gold bolt on top of the filling, which retained a denture tooth. In 1870, T.W. Richmond<sup>11</sup> introduced a cast post-crown technique for endodontically treated teeth that was to be used for years, and other techniques were developed later, such as the Davis crown.<sup>12</sup> During that period, root canal treatment was generally limited to teeth with single roots.

In 1920, Billing and Rosenow<sup>13</sup> introduced the focal infection theory, which led to the belief that nonvital teeth were etiologic agents of common oral diseases, resulting in a rapid decline in endodontic procedures. It took dentistry around 30 years to overcome this bias, and since that time, many refinements have occurred in clinical post systems.

## DENTAL PULP ANATOMY

The idea of “killing the pulp” is to eliminate pain proprioception in the pulp chamber and root canals. Innervation is mainly from the sensory afferents of the trigeminal nerve (fifth cranial nerve) and sympathetic branches from the superior cervical ganglion, which lies opposite the second and third cervical vertebrae. Each bundle contains both myelinated and unmyelinated axons. The majority of fibers are A $\delta$  fibers, which are fast-conducting and range in diameter from 1  $\mu\text{m}$  to 6  $\mu\text{m}$ .<sup>14, 15</sup>

## ENDODONTICALLY TREATED TEETH

Endodontically treated teeth have usually lost a considerable amount of tooth structure due to caries, endodontic treatment, and placement of previous restorations. The root portion of a nonvital tooth is sometimes the only remaining foundation for a crown. The loss of a large portion of tooth structure makes retention of restorations problematic, and it increases the likelihood of fracture. The factors that affect the choice of post and core type depend on the type of tooth and amount of remaining coronal structure; the latter is the most important indicator for prognosis.<sup>16</sup> Conventional root canal filling with or without a post and core adds little or no strength to the restored tooth.<sup>17</sup> Nonvital endodontically treated teeth showed more resistance to fracture than 1-mm ferruled teeth restored with a cast post and core system, a Composipost post and composite resin core system, or a stainless steel post and composite resin core system.<sup>18</sup>

Nonvital endodontically treated teeth lose their elasticity to a degree directly related to the reduction in the amount of dentin and are therefore more susceptible to horizontal and vertical root fractures; the latter is the most common type of root fracture in nonvital teeth.<sup>19</sup> Rosen and Frederick et al.<sup>20,21</sup> demonstrated that nonvital teeth lose their elasticity due to decreased central blood supply and desiccation. Nonvital teeth also lose their elasticity as a result of root canal flaring, which is necessary for gutta-percha condensation. Helfer, Melnick and Schilder<sup>22</sup> found that there was no qualitative change in bound water when they compared vital to nonvital teeth. It was demonstrated that there was 9-percent less moisture in calcified tissues of nonvital teeth compared with vital ones. This process is irreversible even in a saturated atmosphere at body temperature. Laboratory testing has revealed similar fracture resistance in untreated and endodontically treated teeth.<sup>23</sup>

Although vital dentin is 3.5-percent harder than nonvital dentin, its hardness did not prove to be significantly different. This observation led Sedgley and associates<sup>24</sup> to the conclusion that endodontically treated teeth do not lose significant hardness following endodontic treatment. Huang et al.<sup>25</sup> came to the conclusion that dehydration in vital and nonvital teeth increases the stiffness of dentin. Vital teeth are stronger than teeth restored with pin-retained amalgam core build-up, dowel post with glass ionomer-amalgam alloy combination, and cast core build-up.<sup>26</sup> Unprepared nonvital teeth with resin composite access cavity have demonstrated higher fracture resistance to static loading than root-canal treated teeth with cast post and core, Zirconia post, or resin-ceramic interpenetrating phase composite post with Procera crowns.<sup>27</sup>

#### ENDODONTIC TREATMENT OR EXTRACTION AND IMPLANT PLACEMENT

Implants have been alternative solutions to missing teeth since 2,500 years ago when the Etruscans carved teeth from bones of oxen.<sup>28</sup> Osseointegrated endosseous dental implants are compared with ankylosed teeth because of similarities in bone fusion and rigidity under healthy conditions.<sup>29</sup> Although implants have been used for a long time with success rates up to 100 percent in the anterior region of the mandible,<sup>30-33</sup> not every patient is a candidate for implant placement. There are absolute contraindications to implant placement, such as a recent myocardial infarction or cerebrovascular accident, prosthetic valvular replacement, active cancer therapy, psychiatric disorders, and intravenous bisphosphonate treatment.<sup>34</sup>

#### FERRULE LENGTH

An adequate ferrule is necessary for a successful post-retained restoration. A ferrule is a band formed by the walls and margins of the crown that encircles the

circumference of the residual tooth.<sup>35</sup> A ferrule effect is a collar of 360° surrounding parallel walls of dentin and extending 1.5 mm to 2.0 mm coronal to the finish line of the preparation.<sup>36</sup> A 2.0-mm ferrule preparation was found to be much more resistant to fracture than a nonferruled preparation if debonding did not occur first.<sup>37</sup> The mode of failure for a 2.0-mm ferrule preparation was mainly fracture, whereas a nonferruled preparation failed through debonding.<sup>38</sup> A 2.0-mm ferrule length made teeth more resistant to fracture compared with 1.0-mm to 1.5-mm ferrule length, regardless of the dowel system used.<sup>39</sup> Several studies<sup>40-44</sup> support the concept of having 2.0-mm ferrule preparations in nonvital teeth and provided the benefits over lower ferrule length values. A nonuniform 2.0-mm ferrule makes a tooth more prone to fracture than a uniform 2.0-mm ferrule. A nonuniform 2.0-mm ferrule is more resistant to fracture than a tooth without a ferrule.<sup>45</sup> Ferrule length has a greater influence on the fracture resistance of a root restored with a post than the post length itself after cyclic loading.<sup>46</sup>

#### FERRULE WIDTH

According to Tjan and Whang,<sup>47</sup> a preparation with 1.0 mm of remaining buccal dentin wall is apparently more prone to fracture on horizontal impact than those with 2.0 mm or 3.0 mm of buccal dentin wall. A similar study in 1990 concluded that a 2.0-mm buccal dentin wall increased the resistance to root fracture.<sup>48</sup> A contra bevel is an external bevel arising from the occlusal surface or edge of a tooth preparation and placed at an angle that opposes or contrasts the angle of the surface it arises from.<sup>49</sup> Contra bevels were also found to be effective in augmenting root strength.<sup>47</sup>

## ROOT LENGTH

Root length plays a significant role in the long-term success of nonvital teeth.<sup>23</sup> The need of a long root may interfere with the placement of a 1.5-mm to 2.0-mm ferrule.<sup>39-44</sup> Crown lengthening or orthodontic extrusion of a tooth might be necessary to gain access to more tooth structure for better retention of the coronal restoration. Crown lengthening necessitates raising a buccal and lingual mucoperiosteal flap, and removal of crestal bone. To prevent unpredictable inflammation and bone loss, crown margins should be placed 2 mm to 3 mm supracrestal to the alveolar bone in order to preserve the biological width.<sup>50</sup> To preserve the biological width and a 1.5 mm to 2 mm ferrule, crestal bone must be removed to allow 4.5 mm to 5 mm of supracrestal tooth structure. Heithersay<sup>51</sup> first proposed the use of orthodontic methods to extrude roots with horizontal fractures in the gingival third. Later, Ingber<sup>52, 53</sup> introduced the technique of orthodontic extrusion as a means of treating fractured or carious teeth. To extrude a root, a modified post is cemented into the root canal to enable attachment of the orthodontic elastics. The circumference of the extruded root face is narrower due to the taper of the root; therefore, the emergence profile of the crown is compromised. Sufficient extrusion of the root is required to provide an adequate ferrule of at least 1.5 mm to 2.0 mm, which results in a shorter root within the alveolus and a lower crown-to-root ratio.

## CEMENT AND LUTING AGENTS

Cement is a binding element or agent used as a substance to make objects adhere to each other (e.g.: Panavia 21 by Kuraray Dental), whereas a luting agent is a material used to attach an indirect restoration to prepared teeth,<sup>49</sup> e.g. zinc phosphate.

Panavia 21 has a bond strength to dentin in root canals ranging from 16 MPa at the cervical area to 21 MPa apically.<sup>54</sup> This variation has been attributed to the dentinal tubule density, which decreases from cervical to apical dentin.<sup>55</sup> Bond strength is related to the area of bonded solid dentin rather than tubule density.<sup>56</sup>

Zinc phosphate is one of the oldest luting agents and has been used in dentistry for over a century. In 1879, Dr. Peirce<sup>57</sup> mixed for his colleagues a hard, nearly white material composed of oxide of zinc and glacial phosphoric acid. Since this early descriptive use of zinc phosphate cement, only minor changes have been made by manufacturers in its basic composition. Crowns cemented using zinc phosphate with margins placed in dentin did not demonstrate any significant microleakage difference than those cemented in enamel.<sup>58</sup> Zinc phosphate does not chemically bond to tooth structure.<sup>59, 60</sup>

It was demonstrated that Panavia resin cement gives additional resistance to fracture compared with the brittle conventional zinc phosphate luting agent.<sup>61</sup> Resin bonding of posts significantly lowers microleakage as compared with posts luted with conventional zinc phosphate.<sup>62</sup> Zinc phosphate demonstrated more retention for tapered posts than zinc polycarboxylate or epoxy cements.<sup>63</sup> Panavia 21 and zinc phosphate demonstrate no statistical differences in post retention.<sup>64</sup> According to Schmager et al.<sup>65</sup> zinc phosphate cement used in post cementation exhibited tensile bond strength as good as resin composite cements like Compolute Aplicap, Flexi-Flow cem, Panavia 21 EX, Tenet and Twinlook cement.

The minimal cement film thickness was obtained by using glass ionomer cements according to Wang et al.<sup>66</sup> and White and Kipnis<sup>67</sup>; however, in other studies, lower marginal discrepancies were found with resin cements.<sup>68, 69</sup>

## POSTS

The main purpose of a post is to retain a core in a nonvital tooth that has lost extensive coronal tooth structure.<sup>70, 71</sup> Several authors have shown that an endodontic post of low stiffness leads to more even stress distribution.<sup>6, 18, 72</sup> Turner<sup>73</sup> reported that failures in post- and core-restored teeth were mainly caused by post loosening, followed by apical abscesses and carious lesions with few root or post fractures.

Prefabricated posts are preferably used in a cleaned and prepared root canal because of ease of manipulation, and rapid setting time of the composite resin core, which enables immediate tooth preparation and reduces total cost.<sup>74, 75</sup> Several *in vivo* and *in vitro* studies reported that prefabricated posts can offer a better prognosis than cast post and cores for endodontically treated teeth.<sup>76-78</sup>

Alves et al.<sup>79</sup> concluded that immediate restoration of the tooth with a prefabricated post and composite resin core was preferable to placing a temporary post-crown before a final cast post and core. It was shown by Terata<sup>80</sup> that both eugenol-containing and eugenol-free temporary cements decreased the tensile bond strength of resin-luting cements to bovine teeth. On the other hand, Mannocci and coworkers<sup>81</sup> demonstrated no effect of using temporary filling materials with zinc oxide and eugenol on carbon fiber posts with composite resin core restorations.

Cast post and core technique requires a procedure that is more time-consuming and less cost effective; however, the main advantage of using a cast post and core technique is the ability to conform to any canal space, to provide a good fit, and to replace lost tooth structure.<sup>82, 83</sup>

Komada et al.<sup>84</sup> demonstrated that nonvital teeth restored with cast post and cores in normal bone level (2 mm below the cemento-enamel junction) had significantly higher fracture resistance than glass fiber posts with composite resin

cores. When nonvital teeth were restored with cast post and cores in resorbed bone (5 mm below the cemento-enamel junction), there was no significant difference in fracture resistance between cast post and core restorations versus glass fiber posts with composite resin core build-up. It was found that increasing the post width does not increase post retention significantly.<sup>63, 85</sup> Longer posts demonstrated more retention than shorter ones.<sup>63</sup> It was also found that short posts transmit greater lateral forces to the remaining root structure compared with longer posts.<sup>86</sup>

Fiber posts have an elastic modulus ( $E = 20$  GPa) similar to that of dentin (18 GPa) when compared with cast and prefabricated metallic posts ( $E = 200$  GPa). Thus, stresses along the remaining tooth structure are distributed instead of concentrated,<sup>7, 87-92</sup> which would explain the lack of significant root fractures.<sup>7</sup> FiberFill (Pentron, Wallingford, CT) (Glass fiber obturator- post with gutta percha tip) demonstrated significantly higher fracture resistance values compared with conventional cast post and core, FiberKor (glass fiber post), and metal prefabricated posts.<sup>93</sup> Prefabricated metal posts and cast post and cores have been used for a long time and are still being used as the standard treatment. It is found they increase the risks of root fractures.<sup>6</sup> Although fiber posts are found to be affected by moisture, modulus or elasticity and flexural strength levels exceeded the strength necessary to avoid fracture of the post during function.<sup>6</sup>

In a survey made in the late 1980s, it was estimated that around 25 percent of all prosthetically restored teeth are nonvital and endodontically treated before prosthetic restoration.<sup>94</sup> Questionnaire surveys of dentists in the US, Sweden, Germany, and Switzerland have shown disagreements about prosthetic treatment of endodontically treated teeth. Surveys included but were not limited to current



philosophies in treating nonvital teeth, ferrule effects, post types and cements used.<sup>95-</sup>

97

## PINS

Watson<sup>98</sup> showed that using a pin or pins for crown retention has a splinting effect. He concluded that the addition of one or more pins nearest the occlusal forces improves stress distribution and results in less destructive shearing forces exerted on the root. Several years later Newberg et al.<sup>99</sup> also supported Watson's theory. Moll et al.<sup>100</sup> showed that pin placement according to Nealon's technique<sup>101, 102</sup> with composite resin core was at least four times stronger than cast post and cast core.

## RESILON

Resilon (Resilon Research, North Branford, CT) is a root canal obturation material made of synthetic polymer-based soft resin as an alternative to gutta-percha. Resilon requires a sealer such as methacrylate resin to complete obturation of a root canal system.

Calcium hydroxide has been advocated as an intracanal medicament when endodontic treatment cannot be accomplished in one visit. It was found that using 17-percent of EDTA (Ethylenediamine tetraacetic acid) to remove the remnants of calcium hydroxide did not affect the Resilon seal in the obturated root canal system.<sup>103</sup>

Despite the findings of Williams et al.,<sup>104</sup> Resilon has been shown to be significant in regard to sealing properties and reductions in periapical inflammation. According to Shipper et al.,<sup>105</sup> Resilon with a methacrylate resin sealer (Epiphany; Pentron Clinical Technologies, Wallingford, CT) demonstrated a reduction in microleakage up to six times compared with gutta-percha with AH-26 sealer. Another

study by Shipper et al.<sup>106</sup> showed that teeth obturated with Resilon demonstrated significantly less apical periodontitis than teeth obturated with gutta-percha. Dye penetration tests in obturated nonvital teeth showed the least apical microleakage when obturated with Resilon compared with gutta-percha.<sup>107-109</sup> According to Teixeira et al.,<sup>110</sup> single-rooted teeth obturated with Resilon showed significantly more resistance to fracture than teeth obturated with gutta-percha, which has been attributed to the monoblock concept.

Tay et al.<sup>111</sup> found no significant difference in microleakage between Resilon and gutta-percha; the gaps in the Resilon/Epiphany group were between Epiphany and dentin walls, whereas in the other group, the gap was between gutta-percha and AH-26 sealer. Biggs et al.<sup>112</sup> also found no significant difference between teeth restored with gutta-percha with either Roth or AH plus sealers and Resilon with Epiphany sealer. Such an observation challenges the monoblock concept described by Teixeira et al.<sup>110</sup>

Immediate post space preparation after obturation with Resilon was shown to have better apical seal than with gutta-percha/AH-Plus. Also in that study, it was shown that a delayed post space preparation (7 days) provided better apical seal using Resilon obturated root canals compared with using gutta-percha/AH-Plus.<sup>113</sup>

#### APICAL MICROLEAKAGE

Microleakage is the passage of bacteria, fluids, molecules or ions between a cavity wall and the restorative material applied to it.<sup>114</sup> Endodontically treated teeth need to be assessed carefully for the following to prevent microleakage inside the root canal treated tooth: good apical seal, no sensitivity to pressure, no exudates, no fistula, no apical sensitivity and no active inflammation.<sup>19</sup> A proper apical seal of 4 mm to 5 mm of gutta-percha is the minimum amount that should remain.<sup>115-119</sup> Frogel<sup>120</sup>

evaluated various prefabricated post and core systems with a fluid filtration microleakage test and found that none of the post systems tested were capable of consistently achieving a fluid-tight seal.

#### CORONAL MICROLEAKAGE – CROWN MARGIN

A margin is defined as the outer edge of a crown, inlay, onlay, or other restoration.<sup>49</sup> Coronal marginal leakage at the interface of endodontically treated teeth with their artificial crowns may result in recurrent caries and failure of both the restoration and the root canal treatment.<sup>121</sup> According to a survey made by Bronson et al.,<sup>122</sup> prosthodontists found crown margin openings up to 62  $\mu\text{m}$  to be acceptable clinically before final cementation.

There are several methods for evaluating crown margins after cementation:

- 1) Tactile examination using an explorer.
- 2) Bitewing and periapical radiographs.
- 3) Examination of marginal fit using impression materials.<sup>123</sup>

Assif et al.<sup>124</sup> demonstrated that an explorer has an average 50- $\mu\text{m}$  tip. An impression material film thickness could be as low as 6  $\mu\text{m}$  to 30  $\mu\text{m}$  allowing it to capture more details of open margins. Radiographic images are helpful in detecting subgingival overhangs of crowns that cannot be detected in impression-making unless gingival retraction is performed. Impression-making was more accurate in detecting open margins than tactile examination using an explorer or radiographs, although each proved to be useful. There are several studies that agree on having a proper fit of crown margins to prevent periodontal disease and subsequent failure of the restoration.<sup>123, 125-133</sup> Crown margins are affected by the compositional stability of the cast gold used whether as-received or recast. Although the difference in accuracy of

the margin of a crown was statistically significant between the two types of gold previously mentioned, the findings were not clinically significant.<sup>134</sup>

The incomplete fit of full cast crown restorations has been a problem for dentists, which has led many researchers to study this problem.<sup>135-139</sup> Many researchers have agreed that the use of a die spacer during fabrication of a full cast crown improves the fit at cementation.<sup>135, 138</sup> Die spacers allow increased space between the tooth surface and the internal surface of the casting. This reduces stress areas created during cementation, and thereby resulting in a better fit and retention of the final restoration.<sup>135, 137, 138, 140, 141</sup> It was believed in the past that frictional fit between the coping and the tooth surface increased retention,<sup>142</sup> which makes a good fit difficult when a die spacer is being used.<sup>143-146</sup> Die spacers should be applied in layers according to the manufacturers' instructions on the entire preparation on the die down to 0.5 mm short of the preparation margin.<sup>147</sup>

Grajower and Lewinstein<sup>148</sup> indicated that an optimum fit of the casting can be obtained only if relief space allows for cement film thickness, roughness of the tooth, and casting surfaces. They recommended a 50- $\mu\text{m}$  spacer to compensate for the cement film and surface roughness of the casting, which is around 30  $\mu\text{m}$ , and for the wax pattern distortion, which is about 20  $\mu\text{m}$ .

Bronson et al.<sup>122</sup> found in his study that the clinically acceptable margins of a cemented crown do not exceed 130  $\mu\text{m}$ . Marginal adaptation was found to be adversely affected by cyclic loading, which was correlated to the method of application of the core material.<sup>149, 150</sup>

## ESTHETICS

Esthetics has always been a challenge in dentistry. One way to overcome this challenge in endodontically treated anterior teeth is to make prefabricated esthetic

posts<sup>151-153</sup> such as ceramic posts (Celay), polyester posts reinforced with zirconium fibers (Snowlight), zirconia post (Cosmopost) and fiber posts, which could be either glass or carbon fiber (FRC Postec Plus, PeerlessPost, Aestheti-Post, Light-Post). The dental society's concern escalated to claim the benefits of "metal-free dentistry."<sup>154-156</sup> This claim is not true since dental ceramics contain metals<sup>157</sup> such as zinc, zirconium or aluminum. There is no evidence to support the belief that metal-free dentistry is beneficial.<sup>158</sup>

### CYCLIC LOADING AND LOADING TO FAILURE

Cyclic loading is the repeated loading of a specimen to a specific number of cycles. Loading to failure is the single continuous loading of a specimen with a gradually increasing unidirectional force until the specimen fails. In a study by Stegaroiu et al.,<sup>159</sup> cyclic loading did not affect the retention of cast post and core restorations; however, when prefabricated posts were used in conjunction with a composite core, retention was significantly reduced after cyclic loading. Another study by Hu et al.<sup>160</sup> showed the significance of a ferrule in a post preparation. This study concluded that cast post and cores were more resistant to static loading than the other groups in the study (composite resin post and core, and carbon-fiber-reinforced post with composite resin core). However, fiber-reinforced posts showed a longer fatigue life than the rest of the groups. They were able to conclude from that study that nonrestorable root fractures were seen in both the cast post and core and the fiber-reinforced post groups. The composite resin post and core group demonstrated restorable root fractures in both types of loading, which would make it the most desirable restoration for structurally compromised roots.

## PURPOSE OF THIS INVESTIGATION

This investigation was undertaken to gain more information on composite resin core behavior combined with glass fiber posts and Panavia 21 for crown cementation (under cyclic loading). It is hypothesized that a glass fiber post combined with a composite resin core and Panavia 21 for crown cementation would resist marginal gap opening as good as or better than the other groups. This hypothesis is based on the similarity of the elastic modulus of glass fiber posts to natural tooth dentin<sup>7, 87-92</sup> combined with the adhesive effect of Panavia 21 to tooth structure, silanated composite resin, and tin plated silver palladium alloy. Although it is known that composite resin has a much lower elastic modulus than cast alloys<sup>161</sup> that would tend to deform at lower cyclic stresses, the bonding system used in this glass fiber group tested with Panavia 21 should eliminate marginal gap opening at the lingual surface of buccally loaded, prepared teeth.

Another hypothesis being tested is that cast post and cores would demonstrate higher load-to-failure values than the other groups tested. It is believed that the strength of the casted silver palladium alloy with a good adaption of the post to the canal space would render higher values of fracture resistance than the other groups. Although this type of testing has been done before,<sup>93</sup> various parameters such as ferrule length, root length, and cement used are different from other studies.

## MATERIALS AND METHODS

## SPECIMEN GROUPS

Three groups were tested:

- 1) Group CP: Conventional cast post and core (Elektra,<sup>162</sup> Type IV Silver Palladium White C&B Alloy; Williams Ivoclar Vivadent, Amherst, NY) in conventionally prepared root canals of teeth.
- 2) Group FR: PeerlessPost (Glass fiber; SybronEndo, Orange, CA).
- 3) Group MR: Prefabricated metal posts (Titanium alloy, Parapost XH; Coltene Whaledent, Cuyahoga Falls, OH).

The fatigue method utilized and the statistical analyses here were derived from those described by Thongthammachat et al.<sup>93</sup>

## SPECIMEN FABRICATION

Sixty extracted human canines collected under an IUPUI/Clarian IRB approved protocol were evaluated with a fiber optic light (DEMI LED light curing system; Kerr Corporation, Orange, CA) to demonstrate the absence of cracks or fractures, and by x-ray (x-ray machine cone facing proximal surface) to evaluate the approximate size of the pulp chamber and canal to rule out calcified and immaturely wide canals (more than 3 mm) at 15 mm from the apex, and to verify that all root canals were straight beyond 5 mm from the apex. They were distributed into three groups of 20 teeth each; 10 teeth of each group were fatigue loaded, and the other 10 were continuously loaded to failure.

The coronal portions of all 60 teeth were removed using a diamond saw mounted on a thin sectioning machine (Gillings-Hamco; Hamco Machines, Inc., Rochester, NY) under water spray to produce a flat surface, perpendicular to the long



axis of each tooth at a speed of 2.59 mm/min. All teeth were reevaluated again for any cracks using the same method described previously with a fiber optic light. The remaining root length was  $14.8 \pm 0.5$  mm.

## ROOT CANAL TREATMENT AND OBTURATION

The canal system of each tooth was prepared and obturated using a single-cone technique as follows. An access preparation was made and the content of the canal was removed with a barbed broach. The root length was determined by inserting a #10 file into the canal until the file could be seen emerging from the apical foramen. The working length was established by subtracting 1 mm from the root length. Canal preparations for the full working length began with the #10 file, and proceeded sequentially through a #40 file. Profile series 29 0.04 taper files (Dentsply, York, PA) were used to the full working length in an Endo ITR – Intelligent Torque Reduction (AEU-20; Dentsply Tulsa Dental, Co., Tulsa, OK) handpiece at ratio 1:8, torq 2 and 350 rpm to achieve the required 0.04 mm taper after wicking the sides of the canal with RC Prep microdose (Premier Dental Products, Morristown, PA) to help lubricate the canal and remove calcifications to permit more efficient instrumentation. Alternating rinses of 2.5-percent NaOCl (sodium hypochlorite) and liquid 17 percent EDTA (ethylene diamine tetraacetic acid) were used for irrigation between file sizes followed by drying with absorbent paper points (Henry Schein, Melville, NY). The final irrigation used was EDTA followed by a rinse of sterile water so as not to affect the bonding process of the resin root canal filling material RealSeal (SybronEndo, Orange, CA).

A single-cone technique was employed to obturate the root canal of all teeth using RealSeal. A #40 0.04 mm taper main cone was trial fit and verified to be 1 mm from the anatomical apex. The root canal was conditioned using RealSeal primer

dispensed in a mixing well using the manufacturer's supplied applicator brush and paper points (Henry Schein, Melville, NY) to length. Paper points were used to wick the primer to the apex and the excess primer was removed using dry paper points. RealSeal sealer was dispensed onto a mixing pad and then applied along the entire length of the canal. When obturation was complete, the RealSeal obturation material was light cured in the chamber for 80 seconds, which created an immediate coronal seal. The RealSeal sealer had set in the remainder of the canal for approximately 45 minutes to create a monoblock.

#### POST SPACE PREPARATION

Post space preparation for all teeth was initiated after 7 days from obturation<sup>113</sup> by the use of a universal starter drill included in the PeerlessPost Intro-kit (SybronEndo, Orange, CA) at a speed of 5000 rpm to a depth creating a 9-mm post space. The canals were rinsed with Peridex (chlorhexidine gluconate 0.12-percent oral rinse; Omni Preventive Care, 3M ESPE, West Palm Beach, FL) and dried with paper points (Henry Schein, Melville, NY).

#### GROUP CP POST PREPARATION

For group CP, post space preparation was established using Profile O.S. Orifice Opener (Dentsply, York, PA) size 20 through size 60 to the full 9-mm post space length. The size of the post space was 0.9 mm and 1.4 mm at the apical end and the orifice opening, respectively. An anti-rotational box was created on the lingual surface. Duralay (Reliance Dental Manufacturing, Worth, IL) patterns for casting were prepared according to the manufacturer's instructions, supported by prefabricated plastic posts of 23 mm in length after thinning the apical end for a complete fit in the canal post space. The tooth length from root apex to incisal edge

will be 21.5 mm. Posts and cores were invested in Beauty-Cast (Whip Mix Corp., Louisville, KY) without a ring liner. The distilled water added to the investment powder was 17 ml (2 ml more than the recommended value by the manufacturer to allow a more precise passive fit in the prepared root canal). After casting, each post was trial fit to verify that it would seat passively. All cast post and cores were cemented using zinc phosphate cement (Mizzy Inc., Cherry Hill, NJ).

#### GROUP FR POST PREPARATION

For group FR, PeerlessPost™ (SybronEndo; Orange, CA) size # 3 post with a 0.04 taper was used. The post space was prepared using the drill supplied in the starter kit for post preparation. The glass fiber post was shortened 1 mm from the coronal end and 1 mm from the apical end and then rechamfered to the original shape. The apical size of the post space was 0.9 mm and the orifice opening was 1.4 mm in diameter. An anti-rotational box was created on the lingual surface. The posts were cemented using ParaCem Universal DC (Coltene Whaledent, Cuyahoga Falls, OH) according to the manufacturer's instructions.

#### GROUP MR POST PREPARATION

For group MR, ParaPost XH (Coltene/Whaledent, Cuyahoga Falls, OH) size # 3 was used with the drill supplied with it in the starter kit for post preparation. The post space preparation was 9 mm in length with parallel sides according to the manufacturer's instructions. The apical end and orifice opening of the post space were 0.9 mm in diameter. An anti-rotational box was created on the lingual surface. All titanium posts were shortened by 2 mm from the apical end and then rechamfered to the original shape. All titanium posts were cemented using zinc phosphate cement (Mizzy Inc., Cherry Hill, NJ).

## POST CEMENTATION

For groups CP and MR, the canals were coated with zinc phosphate cement (Mizzy Inc., Cherry Hill, NJ) by using a size # 2 Lentulo spiral (Dentsply Canada, Woodbridge, ON). The posts were coated with the same cement and inserted in the prepared canal, allowed to rebound to release hydraulic pressure and then gently resealed. This procedure was repeated until the post seated passively without rebound. A static load was applied using a 1 Kg force until the cement set completely for a minimum of 10 min.<sup>163</sup> For group FR, the posts were cemented using ParaCem Universal DC (Coltene Whaledent; Cuyahoga Falls, OH) by coating the post with cement after using ParaBond Non-Rinse Conditioner and ParaBond Adhesive A and B according to the manufacturer's instructions.

## GROUP MR AND FR CORE PREPARATION

Groups MR and FR cores were fabricated using CoreRestore 2 (Kerr Corp., Orange, CA). The dentin was etched with a 37-percent phosphoric acid gel for 15 seconds, rinsed for 15 seconds and blot dried. Optibond Solo Plus (Kerr Corp., Orange, CA) was applied with a micro brush for 15 seconds with a light brushing motion and air-thinned for 3 seconds to achieve a visibly uniform layer.<sup>164</sup> The adhesive was light-cured for 20 seconds. The core was built up by adding no more than 2 mm<sup>2</sup> bulk increments of composite resin and curing for 40 seconds each using a DEMI LED light curing system (Kerr Corp., Orange, CA) and prepared to the form needed, so that the tooth length from root apex to incisal edge was  $21.5 \pm 0.5$  mm and the form would be ready to receive a metal coping. After 14 days stored under distilled water replaced at least once a week, all CoreRestore 2 (Kerr Corp., Orange, CA) core build-ups were prepared to compensate for the composite resin core

expansion.<sup>165, 166</sup> The lingual thickness of the core material on top of the post had a minimum of 1.5 mm with a lingual surface 45° to the long axis of the tooth.

All teeth were prepared for full coverage crown restorations by creating a 2-mm ferrule. A 1-mm shoulder<sup>167</sup> was made on the facial surface extending to the proximal line angles with the lingual surface having a 0.5-mm chamfer finish line.

#### IMPRESSION AND DIE FABRICATION

After all groups were fitted with their posts and cores, dies were made of each tooth using PVS impression material. Examix NDS injection-light body (GC America Inc., Alsip, IL) was injected directly on the tooth and Examix monophasic injected in an impression tray coated with a universal VPS adhesive (GC America, Inc., Alsip, IL). The impression material was allowed to set for 10 minutes and then poured in Type IV stone (Silky-Rock violet; Whip Mix Corp., Louisville, KY). All dies were trimmed and prepared after applying one coat of die hardener (Harvest Dental Products, Brea, CA) on the entire preparation and two coats of die spacer (Harvest Dental Products, Brea, CA) on the entire preparation 0.5 mm to 1 mm from the margins.

#### WAX PATTERN FABRICATION

Each crown was waxed to a height of 22.5 mm using Yeti Dental Thowax Sculpting Wax (YETI Dentalprodukte GmbH, Engen, Germany). The crowns were prepared with an occlusal convergence of 6° to 10° with a flat area from 5 mm to 6 mm incisal to the lingual margin at 45° to the long axis of the tooth. For fatigue loading, a gauge 14 wax loop (made by twisting around the shank of a long shank bur) was incorporated on the facial aspect of the coping wax pattern 3 mm to 4 mm away from the crown facial margin.

## INVESTING AND CASTING

Wax patterns were sprued and then invested in NovoCast (Whip Mix Corp., Louisville, KY) according to the manufacturer's instructions. All coping castings were made using the same alloy used for group CP post and cores.

## COPING CEMENTATION

The copings for group FR were cemented with Panavia 21 (Kuraray America, Inc., New York, NY) after tin plating the intaglio of all copings using MicroTin (Danville Materials, San Ramon, CA) for 2 sec to 6 sec (according to the manufacturer's instructions) and silanating the composite resin cores using Clearfil Ceramic Primer (Kuraray America, Inc. New York, NY) according to the manufacturer's instructions after activating the surface with K-Etchant gel (Kuraray America, Inc. New York, NY) for 5 seconds. The other two groups (CP and MR) were cemented using zinc phosphate (Mizzy Inc., Cherry Hill, NJ) without tin plating the copings. All cementation procedures were kept under a constant 1 kg load after complete seating until complete cement setting occurred.

## SPECIMEN PREPARATION FOR TESTING

Each root was coated with a thin-layer of Examix NDS injection-light body (GC America Inc., Alsip, IL) to simulate the PDL.<sup>168</sup> The teeth were attached to a surveyor (Dentsply Ceramco, York, PA) to align the long axis, and then invested in autopolymerizing resin (Orthodontic Resin, Dentsply Caulk, Milford, DE) at a level of 2 mm to 3 mm below the margin of the preparation to simulate the biologic width.

All teeth were stored in 100-percent relative humidity (RH) at 37°C for 24 hours before being tested.

## LOAD TO FAILURE

For each group, 10 specimens were loaded 6 mm coronal to the crown margins with a continuous compressive force at a 45-° angle<sup>72, 93</sup> to the long axis of the tooth and a crosshead speed of 2 mm/min<sup>93</sup> until failure using a MTS Sintech Renew Universal Testing machine (Eden Prairie, MN) with TestWorks software. After testing, all specimens were examined to record the location and nature of failure.

## FATIGUE LOADING

For each group, the other 10 specimens were placed into a jig and screwed to the stationary member of a testing machine. The specimens were then loaded at 135 °<sup>169-171</sup> to the long axis of the tooth by means of pulling from the reverse side through a ring intermittently with a 120 N force at a frequency of 2 cycles per second<sup>81, 93</sup> for 100,000<sup>171-174</sup> cycles, using an MTS Bionix 858 Test System machine (Eden Prairie, MN). One hundred thousand cycles is equivalent to 144 days with a correlation coefficient between the *in vitro* and the *in vivo* depths of 0.94.<sup>175, 176</sup> Although reported incisive force values vary, this force is 80 percent of maximum average biting force as reported by Garner and Kotwal.<sup>177</sup>

## MARGINAL GAP MEASUREMENT

Marginal gaps between the cast crown and the tooth margin were measured mid-facial and mid-lingual on all cyclic loaded teeth. After all crowns were cemented, marginal gap measurements were recorded just before and after cyclic loading for those teeth that did not fail by cutting grooves on the teeth mid-facially and lingually for measurement repeatability (Figure 10). The marginal gap was measured in microns using a Quadrachek II (Mentronics, Bedford, NH) connected to a Nikon Measurescope UM-2 (Nikon, Melville, NY) with optical magnification of X10 (ocular

lens) by X40 (objective lens) for the cyclic loaded group before and after loading from the same marking groove. Cyclic loaded teeth did not undergo loading to failure after marginal gap measurements.

## STATISTICAL METHOD

The fracture resistance (maximum load-to-failure), moment of inertia at cervical area, moment of inertia at fracture site, marginal gap pre-loading, and change in marginal gap after loading were compared among the three post types using a one-way analysis of variance (ANOVA). Pair-wise comparisons among the three groups were performed using Fisher's Protected Least Significant Differences method to control the overall significance level at 5 percent. The averages of the facial and lingual marginal gaps were used in the analyses.

## SAMPLE SIZE JUSTIFICATION

Based on the study by Tan et al.,<sup>45</sup> the within-group standard deviation of the load-to-failure measurements was estimated to be 134 N. With a sample size of 10 specimens per group tested for loading to failure, the study had 80-percent power to detect a difference of 180 N between any two groups, assuming two-sided tests performed at a 5-percent significance level for each test. The study was able to detect a 1.3 standard deviation difference between groups for the change in marginal gap size.

## HYPOTHESES

There were two hypotheses for this study. The first was that the FR group would have less marginal gap opening on the lingual than the other groups. The second was that the CP group would have a higher load at failure than the other groups.



## RESULTS

### LOADING TO FAILURE (Table III)

Group MR had the highest (1432 N) mean followed by group CP (1409 N) and group FR (1214 N). Group FR had the highest (520 N) standard deviation followed by group MR (415 N) and group CP (377 N). The standard error was highest in group FR (164  $\mu\text{m}$ ) followed by group MR (131  $\mu\text{m}$ ) and group CP (119  $\mu\text{m}$ ).

Group CP had the highest (2162 N) maximum load-to-failure at the maximum value followed by group MR (1976 N) and group FR (1878 N). Group CP had the highest (899 N) minimum load-to-failure value followed by group MR (702 N) and group FR (455 N).

The three post types did not have significantly different maximum load-to-failure ( $p = 0.49$ ).

### MOMENT OF INERTIA AT CERVICAL AREA (Table IV)

Group MR demonstrated the highest (2015  $\text{mm}^4$ ) mean followed by group FR (1903  $\text{mm}^4$ ) and group CP (1803  $\text{mm}^4$ ). Group FR had the highest (699  $\text{mm}^4$ ) standard deviation followed by group MR (661  $\text{mm}^4$ ) and group CP (450  $\text{mm}^4$ ). Group FR had the highest (221  $\text{mm}^4$ ) standard error followed by group MR (209  $\text{mm}^4$ ) and group CP (142  $\text{mm}^4$ ).

Group MR had the highest (3407  $\text{mm}^4$ ) maximum moment of inertia at the cervical area followed by group FR (2868  $\text{mm}^4$ ) and group CP (2481  $\text{mm}^4$ ). Group CP had the highest (1022  $\text{mm}^4$ ) minimum moment of inertia at the cervical area followed by group MR (970  $\text{mm}^4$ ) and group FR (840  $\text{mm}^4$ ).

The three post types did not have significantly different moments of inertia at cervical area ( $p = 0.75$ ).

#### MOMENT OF INERTIA AT FRACTURE SITE (Table IV)

Group MR demonstrated the highest ( $431 \text{ mm}^4$ ) mean followed by group FR ( $271 \text{ mm}^4$ ) and group CP ( $209 \text{ mm}^4$ ). Group MR had the highest ( $298 \text{ mm}^4$ ) standard deviation followed by group FR ( $209 \text{ mm}^4$ ) and group CP ( $192 \text{ mm}^4$ ). Group MR had the highest ( $94 \text{ mm}^4$ ) standard error followed by group FR ( $66 \text{ mm}^4$ ) and group CP ( $61 \text{ mm}^4$ ).

Group MR had the highest ( $953 \text{ mm}^4$ ) maximum moment of inertia at the fracture site followed by group FR ( $630 \text{ mm}^4$ ) and group CP ( $549 \text{ mm}^4$ ). Group MR had the highest ( $73 \text{ mm}^4$ ) minimum moment of inertia at the cervical area followed by group CP ( $23 \text{ mm}^4$ ) and group FR ( $15 \text{ mm}^4$ ).

The three post types did not have significantly different moments of inertia at fracture site ( $p = 0.12$ ).

#### FAITGUE LOADING FAILURES

Several fractures occurred in the groups tested here. Some occurred before testing (two split roots in Group CP) and 6 catastrophic root fractures occurred (three in group CP and MR each).

#### FATIGUE LOADING – FACIAL MARGINAL GAP BEFORE TESTING (Table V)

Group MR had the largest ( $30.4 \text{ }\mu\text{m}$ ) facial marginal gap mean followed by group FR ( $26.5 \text{ }\mu\text{m}$ ) and group CP ( $13.7 \text{ }\mu\text{m}$ ). Group MR had the highest ( $25.5 \text{ }\mu\text{m}$ ) facial marginal gap standard deviation followed by group FR ( $21.3 \text{ }\mu\text{m}$ ) and group CP ( $12 \text{ }\mu\text{m}$ ). The standard error was highest in group MR ( $9.7 \text{ }\mu\text{m}$ ) followed by group FR ( $6.7 \text{ }\mu\text{m}$ ) and group CP ( $4.9 \text{ }\mu\text{m}$ ).

The largest maximum marginal gap seen was in Group FR (82  $\mu\text{m}$ ) followed by group MR (77  $\mu\text{m}$ ) and group CP (37  $\mu\text{m}$ ). The largest minimum marginal gap seen was in group FR (9  $\mu\text{m}$ ) followed by group CP (5  $\mu\text{m}$ ) and group MR (4  $\mu\text{m}$ ).

Groups CP had a significantly smaller pre-loading marginal gap than groups FR ( $p = 0.0265$ ) and MR ( $p = 0.0273$ ), while both groups FR and MR did not have a significantly different pre-loading marginal gap ( $p = 0.86$ ).

#### FATIGUE LOADING – FACIAL MARGINAL GAP AFTER TESTING (Table V)

Group MR had the largest (40.1  $\mu\text{m}$ ) facial marginal gap mean followed by group CP (30  $\mu\text{m}$ ) and group FR (23  $\mu\text{m}$ ). Group MR had the highest (38.7  $\mu\text{m}$ ) facial marginal gap standard deviation followed by group FR (22.2  $\mu\text{m}$ ) and group CP (10.1  $\mu\text{m}$ ). The standard error was highest in group MR (14.6  $\mu\text{m}$ ) followed by group FR (7.0  $\mu\text{m}$ ) and group CP (4.1  $\mu\text{m}$ ).

The largest maximum marginal gap seen was in Group MR (121  $\mu\text{m}$ ) followed by group FR (83  $\mu\text{m}$ ) and group CP (36  $\mu\text{m}$ ). The largest minimum marginal gap seen was in group CP (10  $\mu\text{m}$ ) followed by group FR (6  $\mu\text{m}$ ) and group MR (5  $\mu\text{m}$ ).

#### FATIGUE LOADING – FACIAL MARGINAL GAP CHANGE (Table V)

Group CP had the highest (16.3  $\mu\text{m}$ ) facial marginal gap mean followed by group MR (9.7  $\mu\text{m}$ ) and group FR (-3.5  $\mu\text{m}$ ). Group MR had the highest (16.2  $\mu\text{m}$ ) standard deviation followed by group CP (16.1  $\mu\text{m}$ ) and group FR (6.8  $\mu\text{m}$ ). The standard error was highest in group CP (6.6  $\mu\text{m}$ ) followed by group MR (6.1  $\mu\text{m}$ ) and group FR (2.2  $\mu\text{m}$ ).

Group MR had the highest (44  $\mu\text{m}$ ) maximum facial marginal gap change followed by group CP (31  $\mu\text{m}$ ) and group FR (8  $\mu\text{m}$ ). Group MR had the highest (-18

$\mu\text{m}$ ) minimum facial marginal gap change followed by group CP (-5  $\mu\text{m}$ ) and group FR (-1  $\mu\text{m}$ ).

The changes in facial marginal gap was insignificant for group MR ( $p = 0.1636$ ), group FR ( $p = 0.1399$ ) and group CP ( $p = 0.0555$ ).

#### FATIGUE LOADING – LINGUAL MARGINAL GAP BEFORE TESTING (Table VI)

Group FR had the largest lingual marginal gap mean (49.7  $\mu\text{m}$ ) followed by group MR (49.1  $\mu\text{m}$ ) and group CP (15  $\mu\text{m}$ ). Group MR had the highest (35.4  $\mu\text{m}$ ) facial marginal gap standard deviation followed by group FR (22.9  $\mu\text{m}$ ) and group CP (8.8  $\mu\text{m}$ ). The standard error was highest in group MR (13.4  $\mu\text{m}$ ) followed by group FR (7.2  $\mu\text{m}$ ) and group CP (3.6  $\mu\text{m}$ ).

The largest maximum marginal gap seen was in group MR (119  $\mu\text{m}$ ) followed by group FR (93  $\mu\text{m}$ ) and group CP (28  $\mu\text{m}$ ). The largest minimum marginal gap seen was in group FR (24  $\mu\text{m}$ ) followed by group MR (15  $\mu\text{m}$ ) and group CP (6  $\mu\text{m}$ ).

#### FATIGUE LOADING – LINGUAL MARGINAL GAP AFTER TESTING (Table VI)

Group MR had the largest (150.4  $\mu\text{m}$ ) lingual marginal gap mean followed by group FR (64.2  $\mu\text{m}$ ) and group CP (56.3  $\mu\text{m}$ ). Group MR had the highest (91.8  $\mu\text{m}$ ) lingual marginal gap standard deviation followed by group CP (42.6  $\mu\text{m}$ ) and group FR (33.2  $\mu\text{m}$ ). The standard error was highest in group MR (34.7  $\mu\text{m}$ ) followed by group CP (17.4  $\mu\text{m}$ ) and group FR (10.5  $\mu\text{m}$ ).

The largest maximum marginal gap seen was in group MR (352  $\mu\text{m}$ ) followed by group FR (127  $\mu\text{m}$ ) and group CP (122  $\mu\text{m}$ ). The largest minimum marginal gap seen was in group MR (91  $\mu\text{m}$ ) followed by group FR (25  $\mu\text{m}$ ) and group CP (15  $\mu\text{m}$ ).

FATIGUE LOADING – LINGUAL  
MARGINAL GAP CHANGE (Table VI)

Group MR had the highest (101.3  $\mu\text{m}$ ) lingual marginal gap mean followed by group CP (41.3  $\mu\text{m}$ ) and group FR (14.5  $\mu\text{m}$ ). Group MR had the highest (89.9  $\mu\text{m}$ ) standard deviation followed by group CP (35.6  $\mu\text{m}$ ) and group FR (13.7  $\mu\text{m}$ ). The standard error was highest in group MR (34  $\mu\text{m}$ ) followed by group CP (14.5  $\mu\text{m}$ ) and group FR (4.3  $\mu\text{m}$ ).

Group MR had the highest (290  $\mu\text{m}$ ) maximum lingual marginal gap change followed by group CP (101  $\mu\text{m}$ ) and group FR (45  $\mu\text{m}$ ). Group MR had the highest (33  $\mu\text{m}$ ) minimum lingual marginal gap change followed by group CP (9  $\mu\text{m}$ ) and group FR (1  $\mu\text{m}$ ).

The changes in lingual marginal gap were significant for all groups MR ( $p = 0.0246$ ), group CP ( $p = 0.0362$ ) and group FR ( $p = 0.0086$ ).

FATIGUE LOADING – FACIAL  
AND LINGUAL AVERAGE MARGINAL  
GAP BEFORE TESTING (Table VII)

Group MR had the largest (39.8  $\mu\text{m}$ ) average marginal gap mean followed by group FR (38.1  $\mu\text{m}$ ) and group CP (14.3  $\mu\text{m}$ ). Group MR had the highest (28.3  $\mu\text{m}$ ) average marginal gap standard deviation followed by group FR (16.4  $\mu\text{m}$ ) and group CP (5.9  $\mu\text{m}$ ). The standard error was highest in group MR (10.7  $\mu\text{m}$ ) followed by group FR (5.2  $\mu\text{m}$ ) and group CP (2.4  $\mu\text{m}$ ).

The largest maximum marginal gap seen was in group MR (98  $\mu\text{m}$ ) followed by group FR (62.5  $\mu\text{m}$ ) and group CP (21.5  $\mu\text{m}$ ). The largest minimum marginal gap seen was in group FR (21  $\mu\text{m}$ ) followed by group MR (12.5  $\mu\text{m}$ ) and group CP (6.5  $\mu\text{m}$ ).

FATIGUE LOADING – FACIAL  
AND LINGUAL AVERAGE MARGINAL  
GAP AFTER TESTING (Table VII)

Group MR had the largest (95.3  $\mu\text{m}$ ) average marginal gap mean followed by group FR (43.6  $\mu\text{m}$ ) and group CP (43.2  $\mu\text{m}$ ). Group MR had the highest (45  $\mu\text{m}$ ) average marginal gap standard deviation followed by group CP (24.6  $\mu\text{m}$ ) and group FR (19.6  $\mu\text{m}$ ). The standard error was highest in group MR (17  $\mu\text{m}$ ) followed by group CP (10.1  $\mu\text{m}$ ) and group FR (6.2  $\mu\text{m}$ ).

The largest maximum marginal gap seen was in group MR (178.5  $\mu\text{m}$ ) followed by group FR (80  $\mu\text{m}$ ) and group CP (79  $\mu\text{m}$ ). The largest minimum marginal gap seen was in group MR (55  $\mu\text{m}$ ) followed by group FR (20.5  $\mu\text{m}$ ) and group CP (15.5  $\mu\text{m}$ ).

FATIGUE LOADING – FACIAL  
AND LINGUAL AVERAGE MARGINAL  
GAP CHANGE (Table VII)

Group MR had the highest (55.5  $\mu\text{m}$ ) average marginal gap mean followed by group CP (28.8  $\mu\text{m}$ ) and group FR (-5.5  $\mu\text{m}$ ). Group MR had the highest (43.1  $\mu\text{m}$ ) standard deviation followed by group CP (24.4  $\mu\text{m}$ ) and group FR (8.5  $\mu\text{m}$ ). The standard error was highest in group MR (16.3  $\mu\text{m}$ ) followed by group CP 9.9  $\mu\text{m}$ ) and group FR (2.7  $\mu\text{m}$ ).

Group MR had the highest (145.5  $\mu\text{m}$ ) maximum average marginal gap change followed by group CP (65  $\mu\text{m}$ ) and group FR (22.5  $\mu\text{m}$ ). Group MR had the highest (23  $\mu\text{m}$ ) minimum facial marginal gap change followed by group FR (-5  $\mu\text{m}$ ) and group CP (2  $\mu\text{m}$ ).

Group FR had significantly less change in marginal gap than group MR ( $p = 0.0013$ ). Groups CP and MR did not have significantly different change in marginal

gap ( $p = 0.09$ ). Groups CP and FR did not have significantly different change in marginal gap ( $p = 0.11$ ).



TABLES AND FIGURES

TABLE I

## Post systems tested

<u>Group</u>	<u>Type of Post</u>	<u>Manufacturer</u>	<u>Composition</u>
CP	Cast post and core	Elektra Williams Ivoclar Vivadent Amherst, NY	Pd 25.0 % Ag 58.3 % Cu 14.7 % In 2.0 % Ru <1.0 % Re <1.0 % Li <1.0 %
FR	Glass fiber	PeerlessPost SybronEndo, Orange, CA	Unidirectional and stretched quartz fiber Epoxy resin
MR	Prefabricated metal	Parapost XH Coltene Whaledent Cuyahoga Falls, OH	Ti alloy

TABLE II

Type of post systems, number of specimens, and type of testing

<u>Group</u>	<u>Post system</u>	<u>No. of specimens</u>	<u>Type of testing</u>
CP	Cast post and core	10*	Fatigue loading
		10	Loading to failure
FR	Glass fiber	10	Fatigue loading
		10	Loading to failure
MR	Prefabricated metal	10**	Fatigue loading
		10	Loading to failure

\* 5 samples were only tested

\*\* 7 samples were only tested

TABLE III

Maximum load-to-failure (Newtons)

	<u>Group</u>	<u>N</u>	<u>Mean</u>	<u>SD</u>	<u>SE</u>	<u>Min</u>	<u>Max</u>
Failure Load	CP	10	1409	377	119	899	2162
Failure Load	FR	10	1214	520	164	455	1878
Failure Load	MR	10	1432	415	131	702	1976

TABLE IV

Moment of inertia (mm<sup>4</sup>)

	<u>Group</u>	<u>N</u>	<u>Mean</u>	<u>SD</u>	<u>SE</u>	<u>Min</u>	<u>Max</u>
At Cervical Area	CP	10	1803	450	142	1022	2481
	FR	10	1903	699	221	840	2868
	MR	10	2015	661	209	970	3407
At Fracture Site	CP	10	209	192	61	23	549
	FR	10	271	209	66	15	630
	MR	10	431	298	94	73	953

TABLE V

Facial marginal gap ( $\mu\text{m}$ )\*

	<u>Group</u>	<u>N</u>	<u>Mean</u>	<u>SD</u>	<u>SE</u>	<u>Min</u>	<u>Max</u>	<u>p-value</u>
Pre	CP	6	13.7	12.0	4.9	5	37	
	FR	10	26.5	21.3	6.7	9	82	
	MR	7	30.4	25.5	9.7	4	77	
Post	CP	6	30.0	10.1	4.1	10	36	
	FR	10	23.0	22.2	7.0	6	83	
	MR	7	40.1	38.7	14.6	5	121	
Change	CP	6	16.3	16.1	6.6	-5	31	0.0555
	FR	10	-3.5	6.8	2.2	-18	8	0.1399
	MR	7	9.7	16.2	6.1	-1	44	0.1636

\* Statistical results are obtained from Appendix I, II and III.

TABLE VI

Lingual marginal gap ( $\mu\text{m}$ )\*

	<u>Group</u>	<u>N</u>	<u>Mean</u>	<u>SD</u>	<u>SE</u>	<u>Min</u>	<u>Max</u>	<u>p-value</u>
Pre	CP	6	15.0	8.8	3.6	6	28	
	FR	10	49.7	22.9	7.2	24	93	
	MR	7	49.1	35.4	13.4	15	119	
Post	CP	6	56.3	42.6	17.4	15	122	
	FR	10	64.2	33.2	10.5	25	127	
	MR	7	150.4	91.8	34.7	91	352	
Change	CP	6	41.3	35.6	14.5	9	101	0.0362
	FR	10	14.5	13.7	4.3	1	45	0.0086
	MR	7	101.3	89.9	34.0	33	290	0.0246

\* Statistical results are obtained from Appendix I, II and III.

TABLE VII

Average marginal gap — facial and lingual ( $\mu\text{m}$ )\*

	<u>Group</u>	<u>N</u>	<u>Mean</u>	<u>SD</u>	<u>SE</u>	<u>Min</u>	<u>Max</u>	<u>p-value</u>
Pre	CP	6	14.3	5.9	2.4	6.5	21.5	
	FR	10	38.1	16.4	5.2	21	62.5	
	MR	7	39.8	28.3	10.7	12.5	98	
Post	CP	6	43.2	24.6	10.1	15.5	79	
	FR	10	43.6	19.6	6.2	20.5	80	
	MR	7	95.3	45.0	17.0	55	178.5	
Change	CP	6	28.8	24.4	9.9	2	65	0.0339
	FR	10	5.5	8.5	2.7	-5	22.5	0.0711
	MR	7	55.5	43.1	16.3	23	145.5	0.0144

\* Statistical results are obtained from Appendix I, II and III.



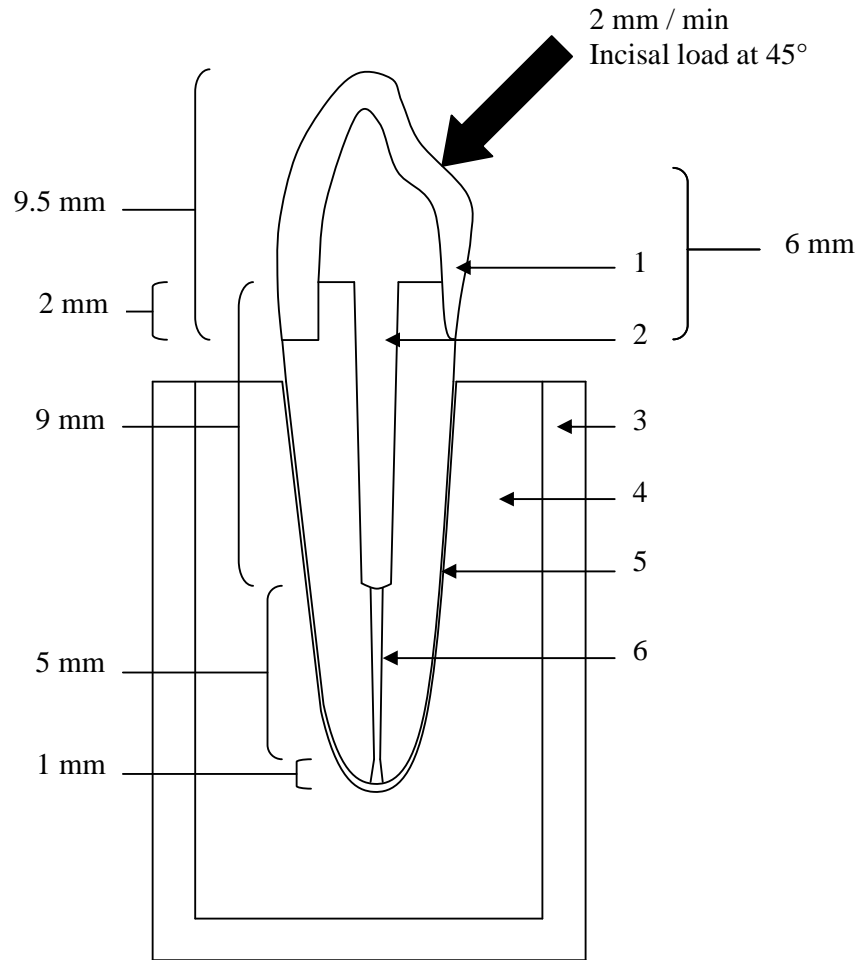

FIGURE 1. Load-to-failure group CP. 1) Coping; 2) Cast post and core – Elektra; 3) CPVC tube; 4) Orthoresin; 5) PVS lining; 6) Resilon.

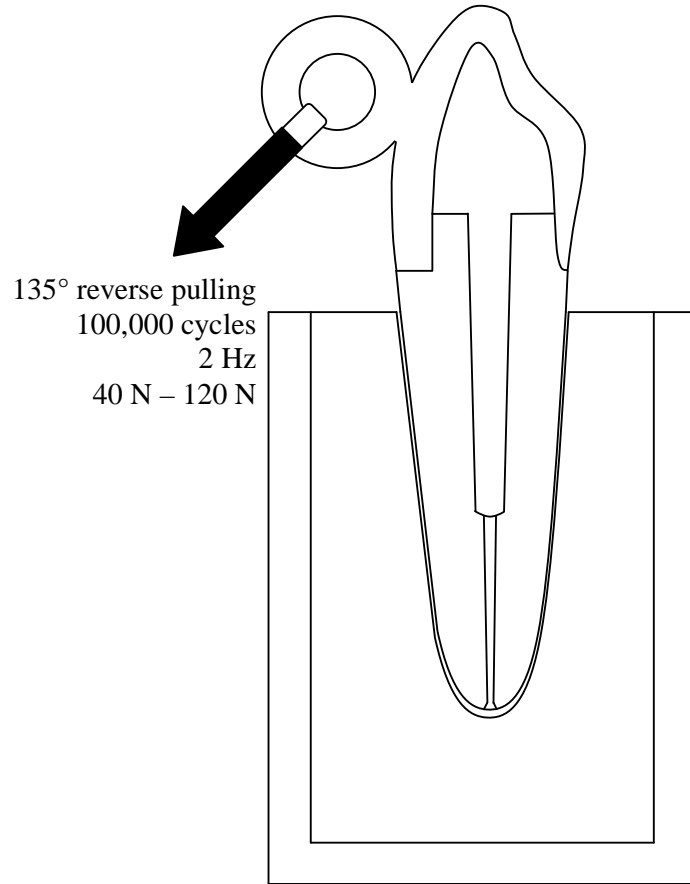

FIGURE 2. Fatigue-loading CP group.

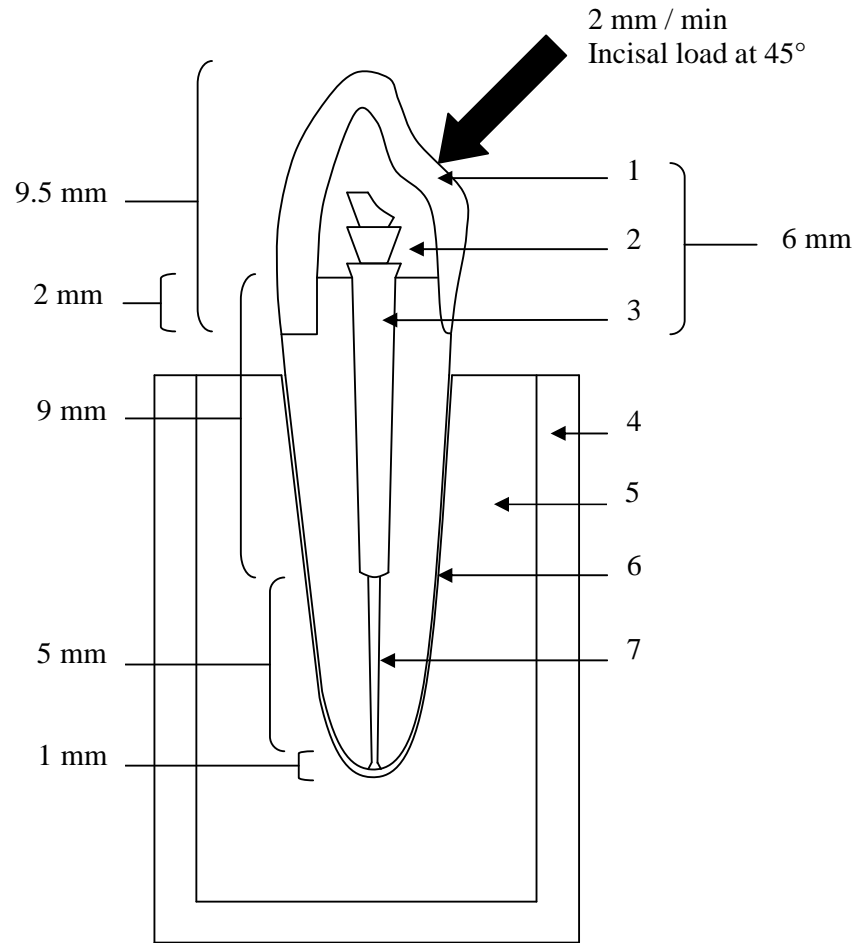

FIGURE 3. Load-to-failure FR group. 1) Coping; 2) Corerestore 2; 3) Glass fiber - PeerlessPost 4) CPVC tube; 5) Orthoresin; 6) PVS lining; 7) Resilon.

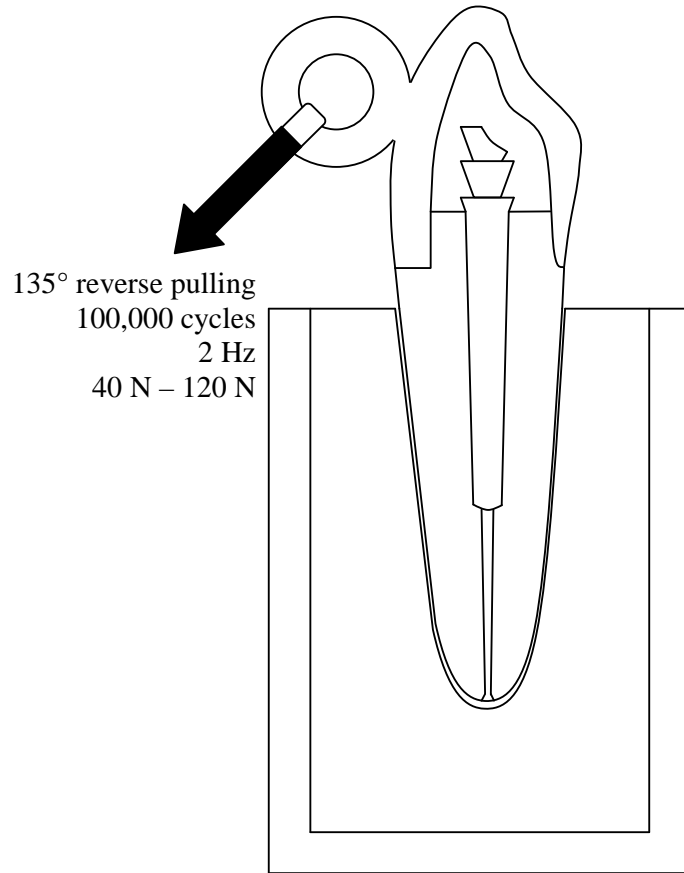

FIGURE 4. Fatigue-loading FR group.

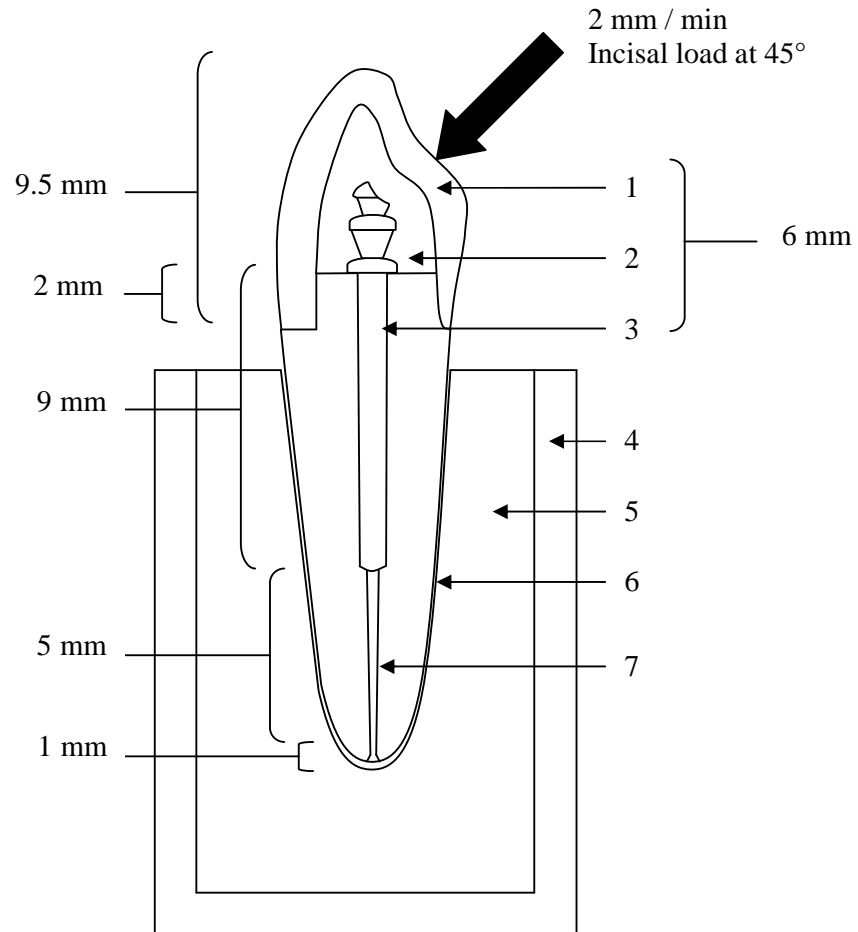

FIGURE 5. Load-to-failure MR group. 1) Coping; 2) Corerestore 2; 3) Titanium – Parapost XH post; 4) CPVC tube; 5) Orthoresin; 6) PVS lining; 7) Resilon.

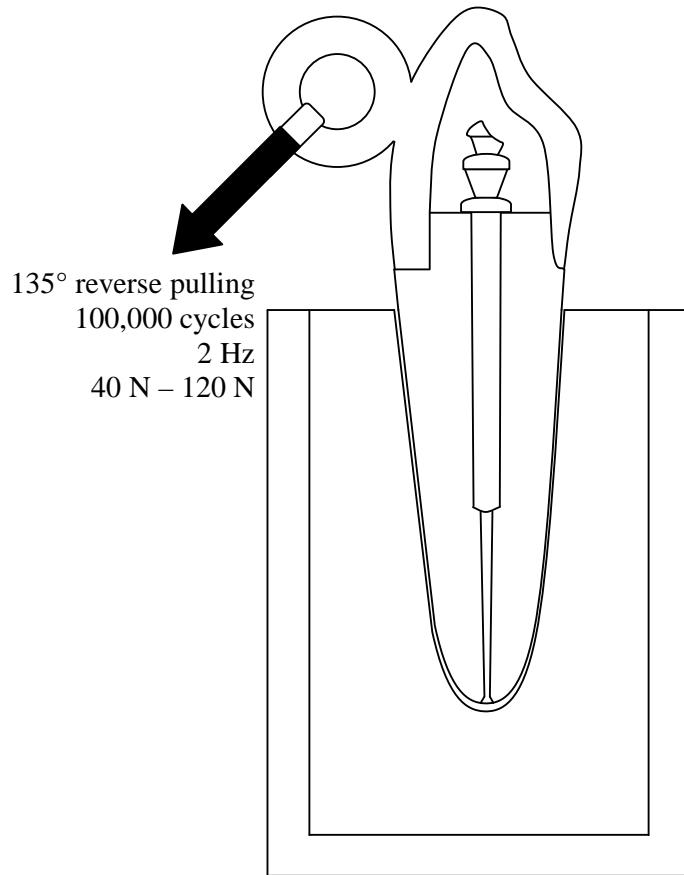

FIGURE 6. Fatigue-loading MR group.

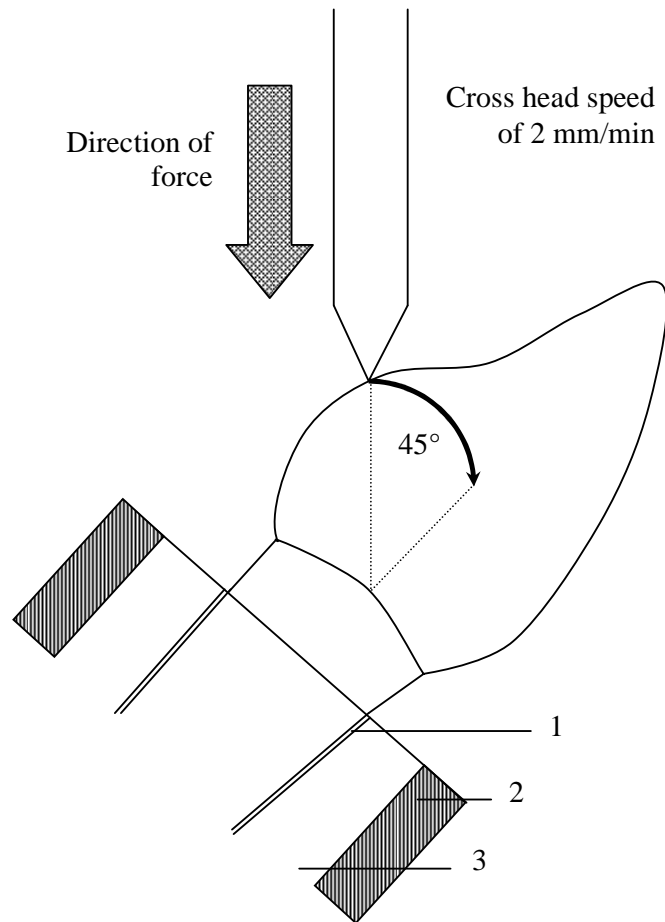

FIGURE 7. Load-to-failure sample. 1) PVS lining to simulate PDL; 2) CPVC tube; 3) Orthoresin.

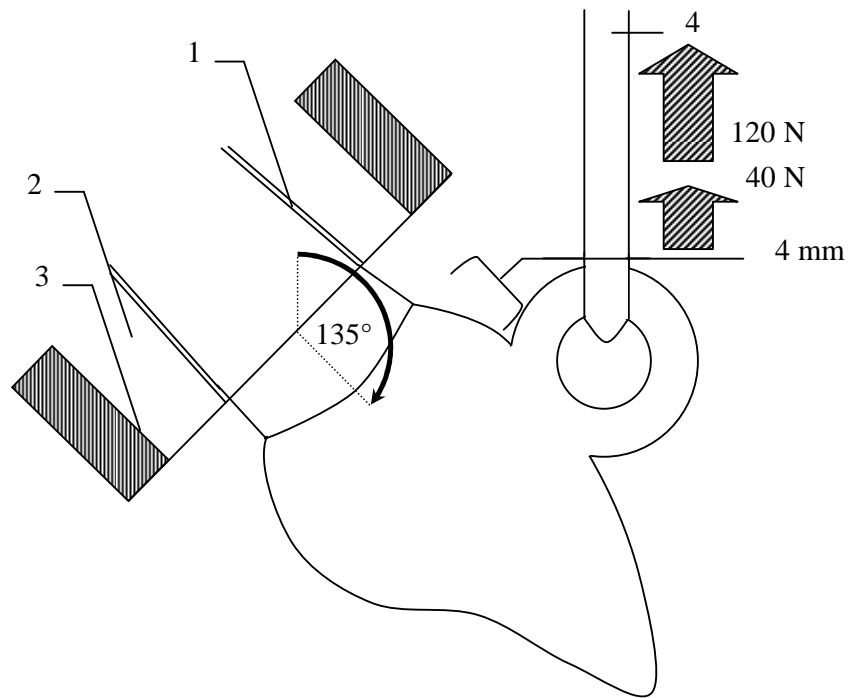

FIGURE 8. Fatigue-loading sample. 1) PVS lining to simulate PDL. 2) Orthoresin; 3) CPVC tube; 4) Spiderwire.



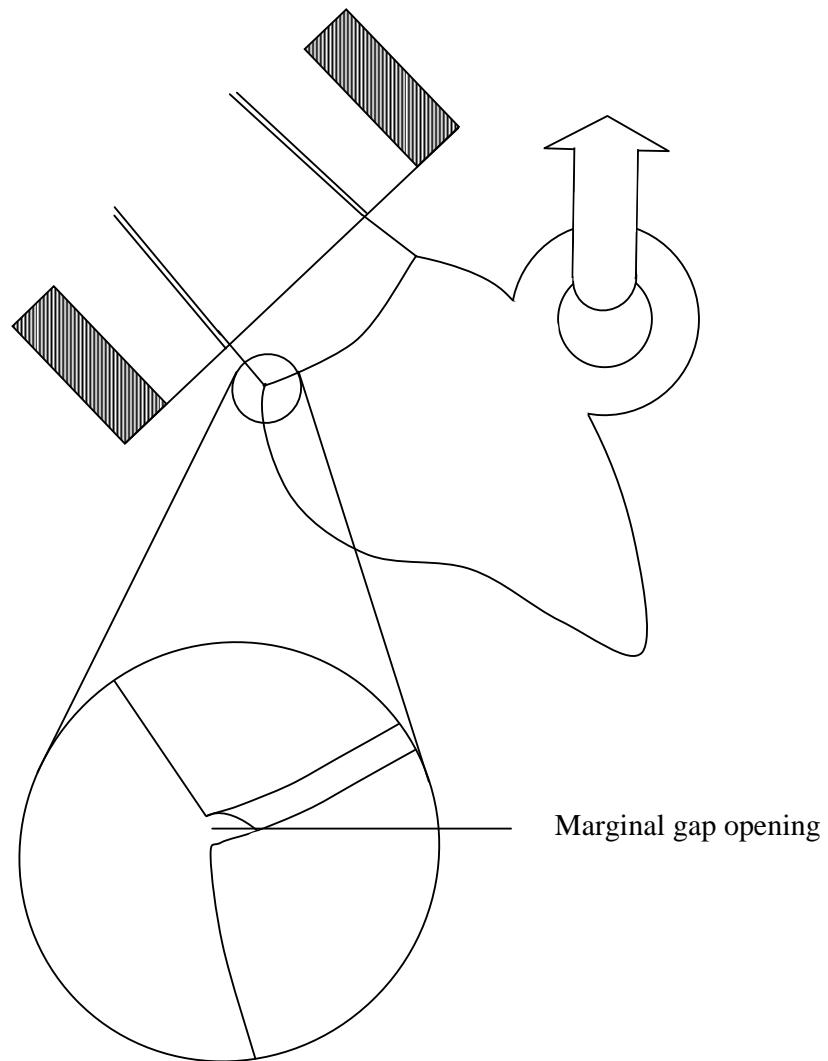

FIGURE 9. Fatigue-loading sample after testing; arrow indicates reverse pull at 135° to long axis of tooth.

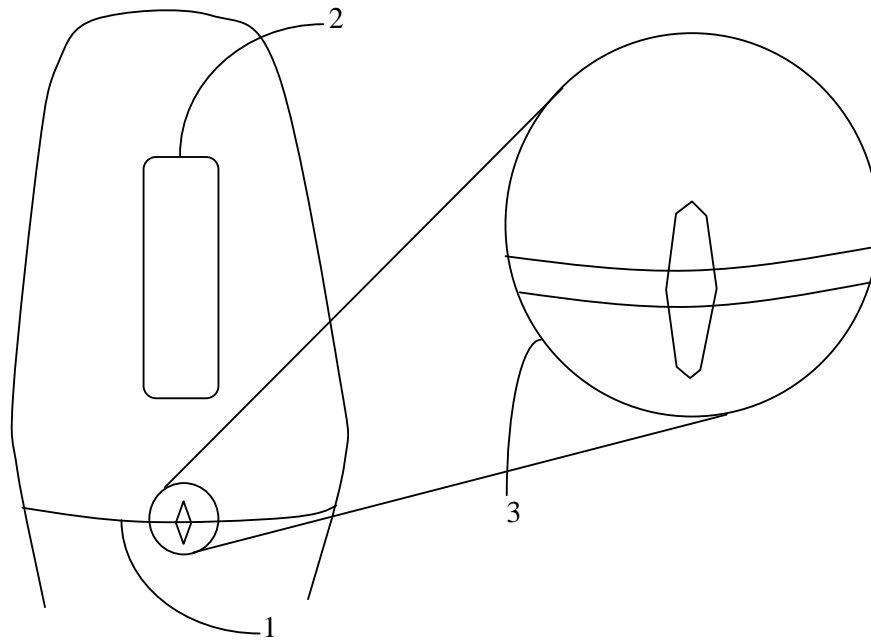

FIGURE 10. Facial view of fatigue-loading sample. 1) Facial margin; 2) Ring on facial surface; 3) Under microscope, marking groove can be seen and measured using a measurescope connected to a microscope before and after cyclic loading.

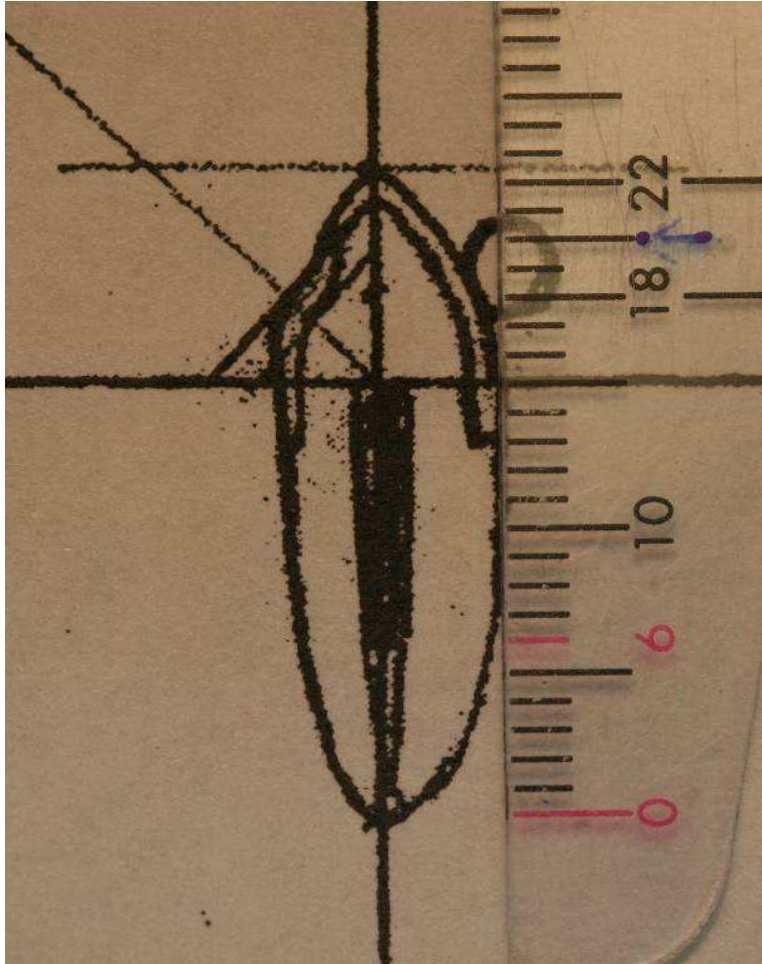

FIGURE 11. Template for teeth reduction and coping wax-up.

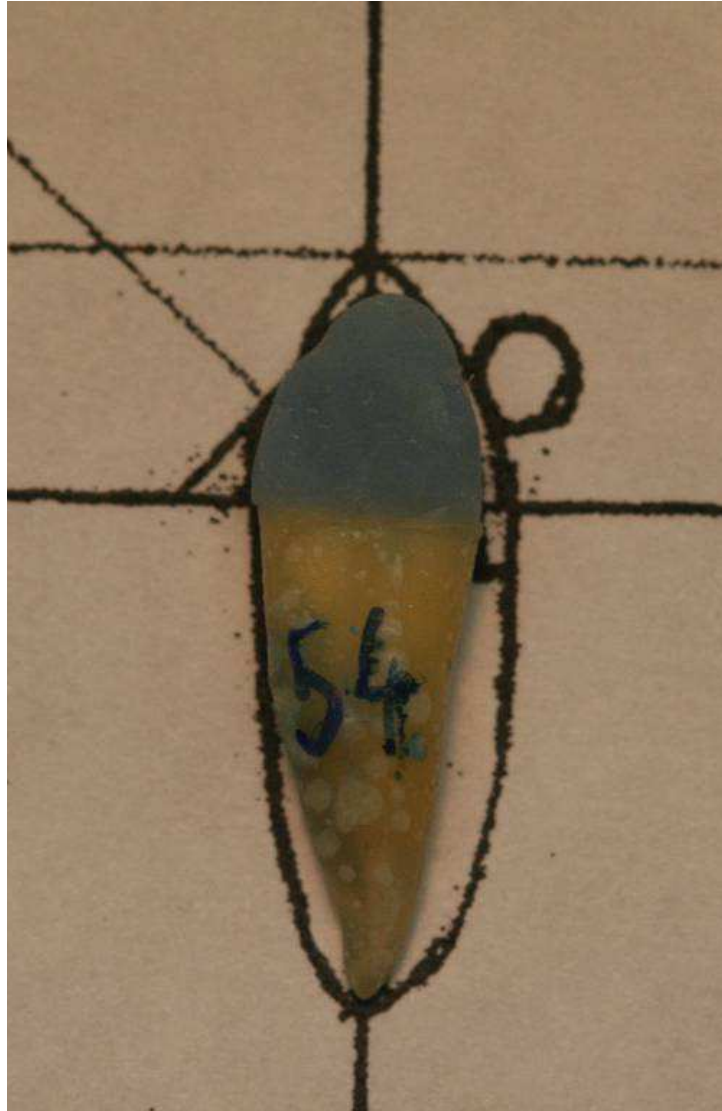

FIGURE 12. Composite core build-up using template.



FIGURE 13. MTS Bionix 858 Test System machine with load-to-failure setup.



FIGURE 14. Tooth sample undergoing load-to-failure testing.



FIGURE 15. MTS Bionix 858 Test System machine with fatigue-loading setup.



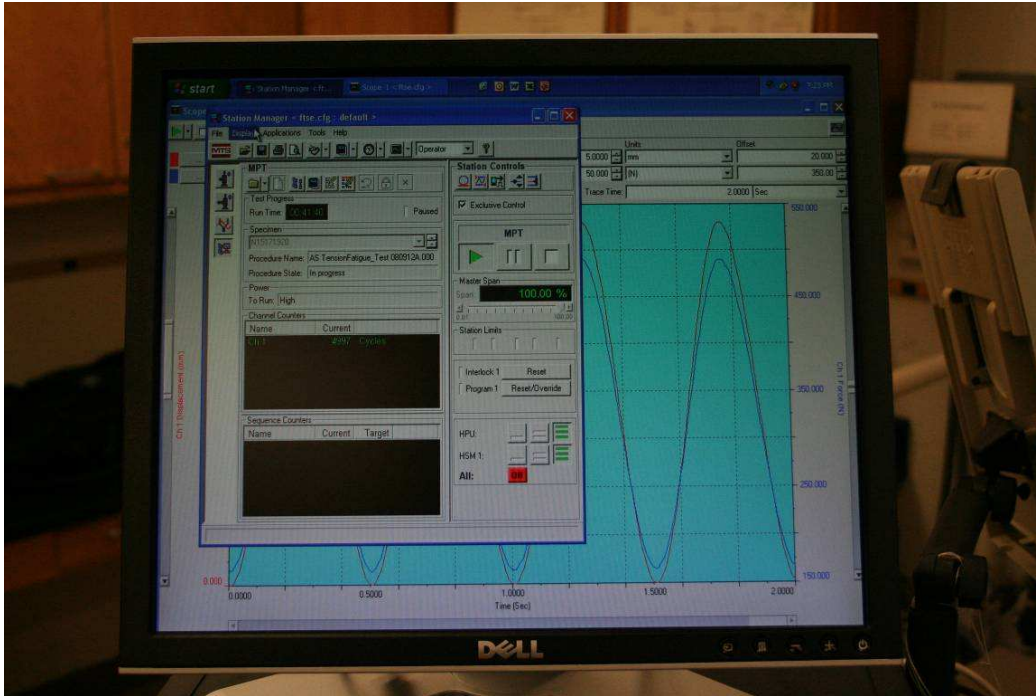

FIGURE 16. Software showing fatigue-loading forces and displacement.





FIGURE 17. Specimen #29 demonstrated a marginal gap  $>200\ \mu\text{m}$  before remaking of the coping.



FIGURE 18. Load-to-failure sample from group CP showing apical fracture. Black arrow indicates fracture line and white arrow indicates force direction.

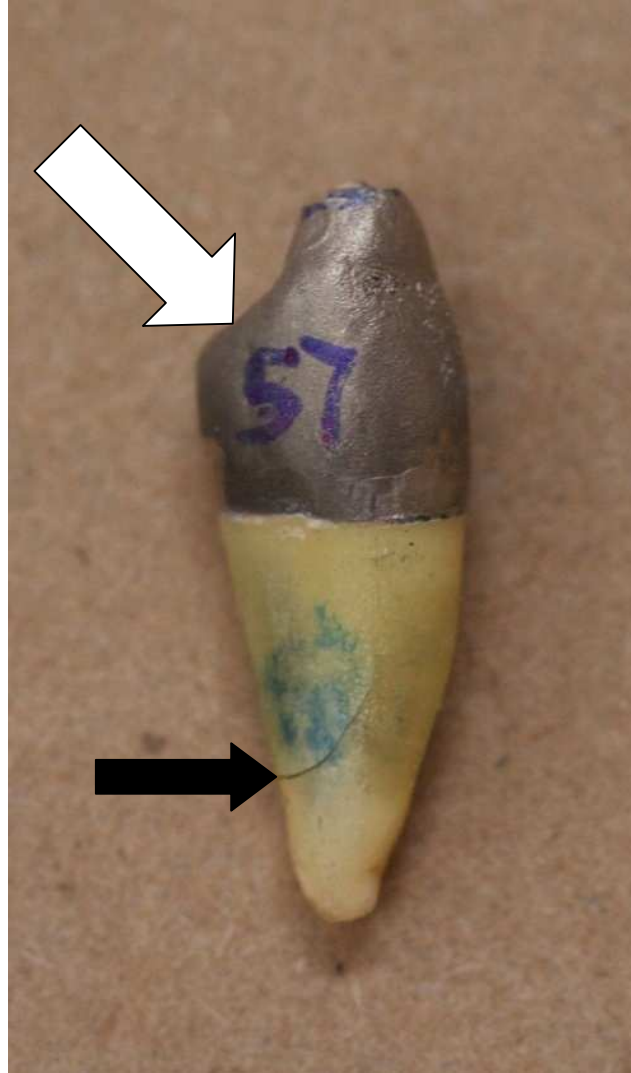

FIGURE 19. Load-to-failure sample from group FR showing junction of middle and apical thirds fracture. Black arrow indicates fracture line and white arrow indicates force direction.

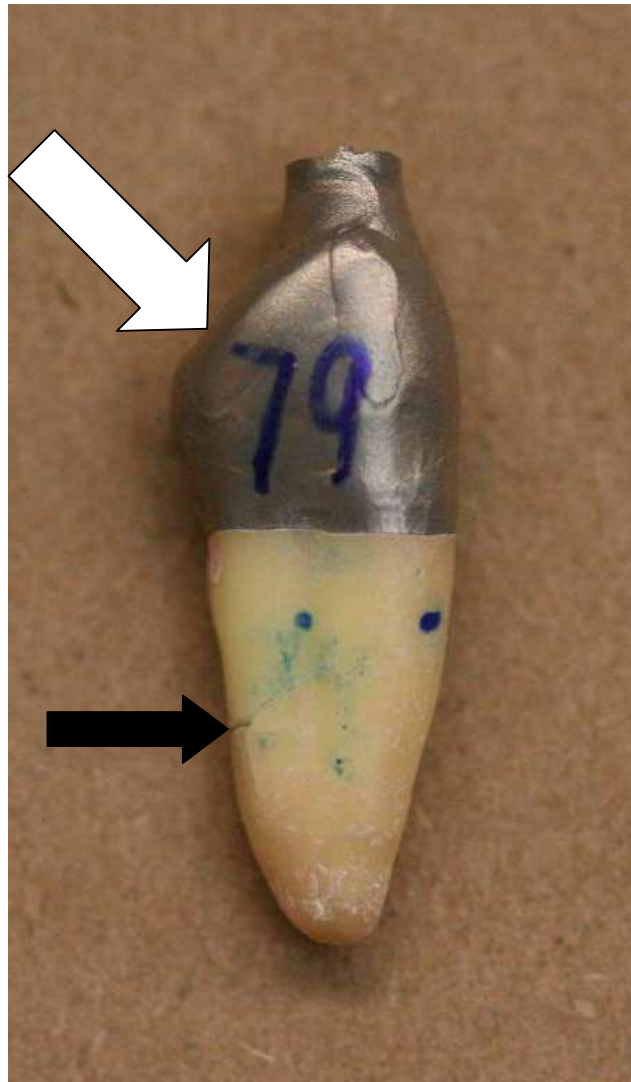

FIGURE 20. Load-to-failure sample from group MR showing middle third fracture. Black arrow indicates fracture line and white arrow indicates force direction.

## DISCUSSION

One of the objectives of restorative dentistry is to conserve and restore natural teeth to function. The restoration of severely damaged or decayed teeth that lack adequate dentinal support at the coronal portion is difficult, even if they have been successfully treated with root canal therapy.

Longevity and survival rate of teeth restored with a post, core and crown after successful endodontic therapy varies significantly. According to a retrospective study by Wegner,<sup>178</sup> teeth that were used in fixed partial dentures have a significantly improved survival rate (92 percent) compared with teeth used as abutments for removable partial dentures (51 percent). Teeth survival factors for removable partial dentures include the tooth type, core material, and diameter of the post; however, tooth survival factors for a fixed partial denture only included the core material type.

#### CAST POST AND CORES

All fractures observed in this group were catastrophic. The most common fracture site seen in group CP was the apical third followed by the junction of the middle and apical thirds with one failure at the junction of the cervical and middle thirds. The highest fracture loads recorded in this group occurred in teeth that demonstrated failure in the apical third. This finding is consistent with the three-dimensional stress analysis by Loney et al.<sup>179</sup> He was able to demonstrate the greatest stress concentrations at the lingual apex of the post.

Custom cast posts and cores have a more intimate fit in the canal than do prefabricated tapered posts, which lead to a different type of stress distribution. This finding is similar to that found by Yaman et al.,<sup>180</sup> who also demonstrated that cast

post and cores yielded the best stress distribution, which was attributed to the superior custom fit of a cast post and core.

Although group CP demonstrated the highest load-to-failure values, three of the fatigue-loaded group failed before or during testing. This decreased fracture resistance of roots restored with cast post and cores was shown clinically by Ferrari et al.<sup>90</sup> when 9 percent of the cast post and core group showed root fractures. Sorensen et al.<sup>86</sup> also showed that tapered cast post and cores demonstrated higher failure rates than teeth treated without intracoronal reinforcement. Another study by Sorensen<sup>181</sup> shows that custom-tapered cast posts have a wedging effect that results in nonrestorable root fractures. Grieznis et al.<sup>182</sup> and Mattison<sup>183</sup> were able to demonstrate that cast post and cores significantly reduce the fracture resistance of teeth and an increased cast post diameter leads to a reduction in fracture resistance.

Passivity of a cast post is very critical in reducing internal stresses. Del Castillo et al.<sup>184</sup> was able to demonstrate that a post diameter was decreased when the casting temperature of the metal ring was reduced to 1112° F using a phosphate bonded investment and without using a cellulose ring liner. This finding was significantly different than those in the other three groups he tested. The first one used a ring liner at 1499° F; the second one had no ring liner at 1499° F and the third one used a ring liner at 1112° F. Post expansion occurred in all three groups tested.

Group CP demonstrated the highest load-to-failure values (both maximum and minimum) of all groups tested in this study. Dilmener et al.<sup>185</sup> demonstrated similar results in his study – although none of the post and cores were restored with copings – when he compared a cast post and core group with a titanium post/composite resin core group, zirconium dioxide post/composite-resin core group and zirconium dioxide

post/ceramic core group. This can be attributed to the superior fit of custom-made cast posts and cores.

## GLASS FIBER POSTS

All fractures observed in this group were catastrophic. Glass fiber posts demonstrated no fractures in the cyclic loading group, which can be attributed to the glass fiber posts' similar elastic modulus to dentin.<sup>7</sup> The clinical longevity of teeth restored with fiber posts up to three years was shown by Fredriksson et al.<sup>7</sup> Another study by Jung et al.<sup>186</sup> demonstrated similar results over a period of at least 5 years and showed no difference between the reliability of cast post and cores to direct post and composite resin core technique.

On the other hand, Segerstrom<sup>187</sup> demonstrated the lack of reliability of fiber posts in function after a mean time of 6.7 years. In this study, lower load-to-failure results were obtained for group FR (both maximum and minimum).

Forberger et al.<sup>188</sup> demonstrated similar load-to-failure results to this study. He was able to demonstrate slightly lower load-to-failure means in the glass fiber group tested as opposed to the other zirconia and gold posts used in the same study. He was also able to demonstrate a higher standard deviation for the glass fiber group than the other groups tested.

In group FR, most teeth fractured at the junction of the middle and apical thirds, followed by the middle third, and two failed at the apical third. Teeth demonstrating the highest load-to-failure fractured at the junction of the middle and apical thirds in this group.



## TITANIUM POSTS

All fractures observed in this group were also catastrophic. According to a study made by Toparli,<sup>189</sup> titanium posts combined with Ni-Cr crowns demonstrated the lowest radial and axial stresses. The maximum stress values occur on the metal-cement interface.

In group MR, most teeth fractured in the middle third, two fractured at the apical third, and only one fractured at the junction of the middle and apical thirds. Teeth showing the highest load-to-failure fractured in the middle third of the root. Seventy percent of the fractures in the load-to-failure MR group passed through the post and involved the middle third of the root (6 mm coronal to the apical end).

Cohen<sup>190</sup> had similar findings in his study. He showed that ParaPosts cemented using zinc phosphate had asymmetric and uneven stresses concentrated apically when vertical or oblique forces were applied.

## FERRULE

All failures in this study were catastrophic in the load-to-failure and cyclic loading groups, and these were attributed to the 2.0-mm ferrule used in all groups. Similar results were obtained by Ng et al.<sup>38</sup> Root fractures were the predominant mode of failure for the 2.0-mm ferrule preparations, whereas in nonferruled preparations, debonding failures were predominant.

Akkayan<sup>39</sup> concluded from his study that the 2.0-mm ferrule length specimens tested, regardless of the type of dowel used, showed significantly higher loads to failure than specimens with either 1.0 mm or 1.5 mm ferrules.

## BUCCOLINGUAL DIMENSION

The reduction in the moment of inertia calculated at the cervical margins of the teeth tested in this study correlated consistently to a reduced load-to-failure. However, an increase in that inertia did not always relate to an increase in load-to-failure.

This finding is supported by Freeman et al.<sup>171</sup> who used two post groups also used in this study, which are the MR and CP groups. He concluded from his study that teeth with similar buccolingual dimensions of the coronal surface had no significant correlation with the number of fatigue cycles to preliminary failure.

## CYCLIC LOADING

Groups CP and MR showed three failed teeth during testing; however, group FR demonstrated no failures. These findings are consistent with the results obtained by Freeman et al.,<sup>171</sup> who experienced in his study two failures in two groups each identical to groups CP and MR used here; however, the third group (#2-Flexi-Post; Essential Dental Systems, Hackensack, NJ) did not experience any failures.

Isidor et al.<sup>72</sup> also concluded that there was a significantly lower failure rate of fiber type posts than of prefabricated parallel-sided/tapered posts or individually cast posts.<sup>191</sup>

## MARGINAL GAP

In this study, all marginal gaps have demonstrated changes on both the facial and lingual surfaces. This is consistent with the findings by Freeman et al.,<sup>171</sup> although his method involved dye penetration. Freeman noticed that leakage consistently occurred at the cement tooth interface. He found no significant difference in the extent of leakage between the three post systems tested. The most common

types of leakage seen were either at the restoration/cement or tooth/cement interface not extending beyond the edge of the post space or down the post space, but short of the apical extent of the post.

The change in marginal gap was not significant on the facial surface of all groups tested. This can be attributed to the axis of rotation/tipping of the crowns on the facial margin. There was a significant change on the lingual surface of all groups tested, and this could be because the lingual surface is the farthest from the axis of rotation (on the facial margin) of the copings.

Group FR demonstrated the least amount of change (45  $\mu\text{m}$ ) on the lingual surface compared with groups CP (101  $\mu\text{m}$ ) and MR (152  $\mu\text{m}$  to 290  $\mu\text{m}$ ). That could most likely be attributed to the cement used and the technique rather than the type of post used (glass fiber, titanium alloy or silver-palladium alloy) since both titanium alloy and silver-palladium alloy posts have a higher modulus of elasticity. According to Barkmeier,<sup>192</sup> tin plating, high noble alloys before bonding with Panavia 21 cement yielded equivalent bond strengths to base metal alloys.

A study by Osman et al.<sup>193</sup> demonstrated the polymerization shrinkage of luting agents used for crown and bridge cementation. The least affected cement at its final polymerization was zinc phosphate followed by Panavia 21, Variolink, All Bond C&B, and Superbond. Osman was able to obtain consistent and reproducible results throughout his study and concluded that large variations were present in the final shrinkage values among the materials tested.

According to Schmage et al.,<sup>65</sup> post retention was tested with various cement types such as zinc phosphate, Panavia 21 EX, Twinlook and other resin composite cements. He concluded from his study that zinc phosphate cement exhibited similar tensile bond strength to resin composite cements. These findings are also supported

by Bergeron et al.,<sup>64</sup> who found that there was no statistical difference in retention of posts cemented with either zinc phosphate or Panavia 21, regardless of the endodontic sealer used.

One of the specimens in group MR demonstrated a larger than usual marginal gap opening of 290  $\mu\text{m}$  on the lingual surface after cyclic loading. This was attributed to the composite resin core separating from the tooth structure – less than 50  $\mu\text{m}$  – that was noticed after the first coping was removed. The reason why the first coping was replaced was because of a 200- $\mu\text{m}$  marginal gap opening after cementation. The first coping did not seat all the way during cementation, which was blamed on the mixing and working time used. This finding can be correlated to the conclusion obtained by Fakiha et al.<sup>163</sup> She was able to demonstrate the decreased setting time – although working time increased – with zinc phosphate using the frozen glass slab technique with rapid mixing. She concluded from her study that rapid setting can result in incomplete seating of the coping.

Another study demonstrated the sensitivity of mixing zinc phosphate cement on its compressive strength. Li et al.<sup>194</sup> showed the alternate pro and con bidirectional rotation method (106.11 $\pm$  4.82 MPa) to be superior to the pulling and pushing with folding method (77.57  $\pm$  6.26 MPa) or the unidirectional rotation method (54.41  $\pm$  5.08 MPa) in compressive strength values.

## FUTURE STUDIES

Longer periods of fatigue loading should be tested for more reliability. Thermocycling teeth would give a better simulation to a natural environment because the oral cavity is constantly subject to hot and cold temperatures. Panavia 21 with tin plating of precious/semi precious alloys should be investigated with the cast post and

core technique, because it demonstrated reduced marginal gap opening at the tooth-coping interface of the teeth tested in group FR.

## SUMMARY AND CONCLUSIONS

There was no significant difference among groups CP, FR and MR in the load-to-failure test. Group CP demonstrated the highest load-to-failure values; however, the highest load-to-failure mean was group MR. All fractures observed in this study were catastrophic. Group FR demonstrated better stress distribution and caused no early fractures in the fatigue-loading group.

All groups demonstrated significant marginal gap changes on the lingual surface after fatigue loading; however, group FR demonstrated <45- $\mu$ m marginal gap opening. In group FR, the reduced marginal gap opening was attributed to the use of Panavia 21 with the proper surface treatments to bond to the tooth structure, resin composite, and the metal coping.

REFERENCES



1. Ring, ME. *Dentistry, an illustrated history*. C.V. Mosby SL. New York: Abrams, 1985.
2. Morgano SM, Muzynski BL, Malone WF. Diagnosis and treatment planning. In: Malone WF, Koth DL, Cavazos D Jr, Kaiser DA, Morgano SM, eds. *Tylman's theory and practice of fixed prosthodontics*. 8th ed. St. Louis: Medio Dental Media International; 1989, p. 3.
3. Wagnild GW, Mueller KI, eds. *Pathways of the pulp*. St. Louis: Mosby; 2002, p. 769-75.
4. Assif D, Bitenski A, Pilo R, Oren E. Effect of post design on resistance to fracture of endodontically treated teeth with complete crowns. *J Prosthet Dent* 1993;69(1):36-40.
5. King PA, Setchell DJ. An in vitro evaluation of a prototype CFRC prefabricated post developed for the restoration of pulpless teeth. *J Oral Rehabil* 1990;17(6):599-609.
6. Torbjorner A, Karlsson S, Syverud M, Hensten-Pettersen A. Carbon fiber reinforced root canal posts. Mechanical and cytotoxic properties. *Eur J Oral Sci* 1996;104(5-6):605-11.
7. Fredriksson M, Astback J, Pamenius M, Arvidson K. A retrospective study of 236 patients with teeth restored by carbon fiber-reinforced epoxy resin posts. *J Prosthet Dent* 1998;80(2):151-7.
8. Grossman LI. Endodontics 1776-1976: a bicentennial history against the background of general dentistry. *J Am Dent Assoc* 1976;93(1):78-87.
9. Hoffman F. *A treatise on the teeth; their disorders and cure*. English short title catalogue Eighteenth century collection; reel 4264, no. 09; 1753.
10. Black GV. A method of grafting artificial crowns on roots of teeth. *Mo Dent J* 1869;1:233.
11. Demas NC. Direct impressions for cast Richmond crown using acetate crown forms. *Dent Dig* 1957;63:258.
12. Baumhammers A. A simplified technique for one-unit cast dowel crown. *Dent Dig* 1962;68:468.
13. Abramson I. The role of endodontics in crown and bridge prosthesis. *J Md State Dent Assoc* 1958;1:28.

14. Cate, A. Oral histology - development, structure, and function. 4th ed. St. Louis: Mosby; 1994, p. 204-11.
15. Standring S. Gray's anatomy. 39th ed. New York: Elsevier; 2005, p. 559.
16. Rosenstiel S, Fujimoto J. Contemporary fixed prosthodontics. 4th ed. St. Louis: Mosby; 2006.
17. Sornkul E, Stannard JG. Strength of roots before and after endodontic treatment and restoration. *J Endod* 1992;18(9):440-3.
18. Sidoli GE, King PA, Setchell DJ. An in vitro evaluation of a carbon fiber-based post and core system. *J Prosthet Dent* 1997;78(1):5-9.
19. Johnson JK, Schwartz NL, Blackwell RT. Evaluation and restoration of endodontically treated posterior teeth. *J Am Dent Assoc* 1976;93(3):597-605.
20. Federick DR, Serene TP. Secondary intention dowel and core. *J Prosthet Dent* 1975;34(1):41-7.
21. Rosen H. Operative procedures on mutilated endodontically treated teeth. *J Prosthet Dent* 1961;11:973-86.
22. Helfer AR, Melnick S, Schilder H. Determination of the moisture content of vital and pulpless teeth. *Oral Surg Oral Med Oral Pathol* 1972;34(4):661-70.
23. Trabert KC, Caput AA, Abou-Rass M. Tooth fracture--a comparison of endodontic and restorative treatments. *J Endod* 1978;4(11):341-5.
24. Sedgley CM, Messer HH. Are endodontically treated teeth more brittle? *J Endod* 1992;18(7):332-5.
25. Huang TJ, Schilder H, Nathanson D. Effects of moisture content and endodontic treatment on some mechanical properties of human dentin. *J Endod* 1992;18(5):209-15.
26. Dabas VK. Comparative evaluation of strength of various core restorative materials for endodontically treated anterior teeth. *Indian J Dent Res* 2000;11(4):139-44.
27. Pontius O, Hutter JW. Survival rate and fracture strength of incisors restored with different post and core systems and endodontically treated incisors without coronoradicular reinforcement. *J Endod* 2002;28(10):710-5.
28. Ring ME. A thousand years of dental implants: a definitive history. (Pt 1). *Compend Contin Educ Dent* 1995;16(10):1060, 62, 64 passim.
29. Tolstunov L. Dental implant success-failure analysis: a concept of implant vulnerability. *Implant Dent* 2006;15(4):341-6.

30. Jemt T, Chai J, Harnett J, et al. A 5-year prospective multicenter follow-up report on overdentures supported by osseointegrated implants. *Int J Oral Maxillofac Implants* 1996;11(3):291-8.
31. Mericske-Stern R, Steinlin Schaffner T, Marti P, Geering AH. Peri-implant mucosal aspects of ITI implants supporting overdentures. A five-year longitudinal study. *Clin Oral Implants Res* 1994;5(1):9-18.
32. Naert I, Gizani S, Vuylsteke M, Van Steenberghe D. A 5-year prospective randomized clinical trial on the influence of splinted and unsplinted oral implants retaining a mandibular overdenture: prosthetic aspects and patient satisfaction. *J Oral Rehabil* 1999;26(3):195-202.
33. van Steenberghe D QM, Calberson L, Demanet M. A prospective evaluation of the fate of 697 consecutive intra-oral fixtures ad modum Branemark in the rehabilitation of edentulism. *J Head Neck Pathol* 1987;6:53-8.
34. Hwang D, Wang HL. Medical contraindications to implant therapy. (Pt 1). Absolute contraindications. *Implant Dent* 2006;15(4):353-60.
35. Cohen S, Burns R. *Pathways of the pulp*. 9th ed. St. Louis: Mosby; 2006.
36. Gegauff AG. Effect of crown lengthening and ferrule placement on static load failure of cemented cast post-cores and crowns. *J Prosthet Dent* 2000;84(2):169-79.
37. Lu Z, Zhang Y, Zhang W, Wang M. [Influence of post-core on the strength of endodontically treated and crowned teeth]. *Zhonghua Kou Qiang Yi Xue Za Zhi* 2002;37(1):43-6.
38. Ng CC, al-Bayat MI, Dumbrigue HB, Griggs JA, Wakefield CW. Effect of no ferrule on failure of teeth restored with bonded posts and cores. *Gen Dent* 2004;52(2):143-6.
39. Akkayan B. An in vitro study evaluating the effect of ferrule length on fracture resistance of endodontically treated teeth restored with fiber-reinforced and zirconia dowel systems. *J Prosthet Dent* 2004;92(2):155-62.
40. Libman WJ, Nicholls JI. Load fatigue of teeth restored with cast posts and cores and complete crowns. *Int J Prosthodont* 1995;8(2):155-61.
41. Lu Z, Zhang Y, Zhang W, Wang M. [Influence of post-core on the strength of endodontically treated and crowned teeth]. *Zhonghua Kou Qiang Yi Xue Za Zhi* 2002;37(1):43-6.
42. Zhi-Yue L, Yu-Xing Z. Effects of post-core design and ferrule on fracture resistance of endodontically treated maxillary central incisors. *J Prosthet Dent* 2003;89(4):368-73.

43. Mezzomo E, Massa F, Libera SD. Fracture resistance of teeth restored with two different post-and-core designs cemented with two different cements: an in vitro study. (Pt 1). *Quintessence Int* 2003;34(4):301-6.
44. Zhang Y, Lu Z, Wang K. [Fracture strength of custom-fabricated celay all-ceramic post and core]. *Hua Xi Kou Qiang Yi Xue Za Zhi* 2002;20(1):39-41, 44.
45. Tan PL, Aquilino SA, Gratton DG, et al. In vitro fracture resistance of endodontically treated central incisors with varying ferrule heights and configurations. *J Prosthet Dent* 2005;93(4):331-6.
46. Isidor F, Brondum K, Ravnholt G. The influence of post length and crown ferrule length on the resistance to cyclic loading of bovine teeth with prefabricated titanium posts. *Int J Prosthodont* 1999;12(1):78-82.
47. Tjan AH, Whang SB. Resistance to root fracture of dowel channels with various thicknesses of buccal dentin walls. *J Prosthet Dent* 1985;53(4):496-500.
48. Joseph J, Ramachandran G. Fracture resistance of dowel channel preparations with various dentin thickness. *Fed Oper Dent* 1990;1(1):32-5.
49. The glossary of prosthodontic terms. *J Prosthet Dent* 2005;94(1):10-92.
50. Fugazzotto PA, Parma-Benfenati S. Preprosthetic periodontal considerations. Crown length and biologic width. *Quintessence Int Dent Dig* 1984;15(12):1247-56.
51. Heithersay GS. Combined endodontic-orthodontic treatment of transverse root fractures in the region of the alveolar crest. *Oral Surg Oral Med Oral Pathol* 1973;36(3):404-15.
52. Ingber JS. Forced eruption. (Pt 1). A method of treating isolated one and two wall infrabony osseous defects--rationale and case report. *J Periodontol* 1974;45(4):199-206.
53. Ingber JS. Forced eruption. (Pt 2). A method of treating nonrestorable teeth--Periodontal and restorative considerations. *J Periodontol* 1976;47(4):203-16.
54. Gaston BA, West LA, Liewehr FR, Fernandes C, Pashley DH. Evaluation of regional bond strength of resin cement to endodontic surfaces. *J Endod* 2001;27(5):321-4.
55. Carrigan PL MD, Furst ML, Sinai IH. A scanning electron microscopic evaluation of human dentinal tubules according to age and location. *J Endodon* 1984;10:359-63.
56. Suzuki T FW. Dental adhesives: site of dentin vs. bonding of composite resin. *Dent Mater* 1988;4:379-83.

57. Chupein TF. Pennsylvania association of dental surgeons. *Dent Cosmos* 1879;21:695
58. White SN, Sorensen JA, Kang SK, Caputo AA. Microleakage of new crown and fixed partial denture luting agents. *J Prosthet Dent* 1992;67(2):156-61.
59. Norman RD, Swartz ML, Phillips RW, Sears CR. Properties of cements mixed from liquids with altered water content. *J Prosthet Dent* 1970;24(4):410-8.
60. Servais GE, Cartz L. Structure of zinc phosphate dental cement. *J Dent Res* 1971;50(3):613-20.
61. Mendoza DB, Eakle WS, Kahl EA, Ho R. Root reinforcement with a resin-bonded preformed post. *J Prosthet Dent* 1997;78(1):10-4.
62. Reid LC, Kazemi RB, Meiers JC. Effect of fatigue testing on core integrity and post microleakage of teeth restored with different post systems. *J Endod* 2003;29(2):125-31.
63. Standlee JP, Caputo AA, Hanson EC. Retention of endodontic dowels: effects of cement, dowel length, diameter, and design. *J Prosthet Dent* 1978;39(4):400-5.
64. Bergeron BE, Murchison DF, Schindler WG, Walker WA, III. Effect of ultrasonic vibration and various sealer and cement combinations on titanium post removal. *J Endod* 2001;27(1):13-7.
65. Schmage P, Sohn J, Ozcan M, Nergiz I. Effect of surface treatment of titanium posts on the tensile bond strength. *Dent Mater* 2006;22(2):189-94.
66. Wang CJ, Millstein PL, Nathanson D. Effects of cement, cement space, marginal design, seating aid materials, and seating force on crown cementation. *J Prosthet Dent* 1992;67(6):786-90.
67. White SN, Kipnis V. Effect of adhesive luting agents on the marginal seating of cast restorations. *J Prosthet Dent* 1993;69(1):28-31.
68. Tjan AH, Li T. Seating and retention of complete crowns with a new adhesive resin cement. *J Prosthet Dent* 1992;67(4):478-83.
69. Wu JC, Wilson PR. Optimal cement space for resin luting cements. *Int J Prosthodont* 1994;7(3):209-15.
70. Goodacre CJ, Spolnik KJ. The prosthodontic management of endodontically treated teeth: a literature review. (Pt 1). Success and failure data, treatment concepts. *J Prosthodont* 1994;3(4):243-50.
71. Robbins JW. Guidelines for the restoration of endodontically treated teeth. *J Am Dent Assoc* 1990;120(5):558, 60, 62 passim.

72. Isidor F, Odman P, Brondum K. Intermittent loading of teeth restored using prefabricated carbon fiber posts. *Int J Prosthodont* 1996;9(2):131-6.
73. Turner CH. Post-retained crown failure: a survey. *Dent Update* 1982;9(4):221, 24-6, 28-9 passim.
74. Baraban DJ. Immediate restoration of pulpless teeth. *J Prosthet Dent* 1972;28(6):607-12.
75. Miller AW, III. Post and core systems: which one is best? *J Prosthet Dent* 1982;48(1):27-38.
76. Isidor F, Brondum K. Intermittent loading of teeth with tapered, individually cast or prefabricated, parallel-sided posts. *Int J Prosthodont* 1992;5:257-61.
77. Perez Moll JF, Howe DF, Svare CW. Cast gold post and core and pin-retained composite resin bases: a comparative study in strength. *J Prosthet Dent* 1978;40(6):642-4.
78. Sorensen JA, Engelman MJ. Effect of post adaptation on fracture resistance of endodontically treated teeth. *J Prosthet Dent* 1990;64(4):419-24.
79. Alves J, Walton R, Drake D. Coronal leakage: endotoxin penetration from mixed bacterial communities through obturated, post-prepared root canals. *J Endod* 1998;24(9):587-91.
80. Goldman M, Simmonds S, Rush R. The usefulness of dye-penetration studies reexamined. *Oral Surg Oral Med Oral Pathol* 1989;67(3):327-32.
81. Mannocci F, Ferrari M, Watson TF. Microleakage of endodontically treated teeth restored with fiber posts and composite cores after cyclic loading: a confocal microscopic study. *J Prosthet Dent* 2001;85(3):284-91.
82. Chan FW, Harcourt JK, Brockhurst PJ. The effect of post adaptation in the root canal on retention of posts cemented with various cements. *Aust Dent J* 1993;38(1):39-45.
83. Kantor ME, Pines MS. A comparative study of restorative techniques for pulpless teeth. *J Prosthet Dent* 1977;38(4):405-12.
84. Komada W, Miura H, Okada D, Yoshida K. Study on the fracture strength of root reconstructed with post and core: alveolar bone resorbed case. *Dent Mater J* 2006;25(1):177-82.
85. Standlee JP, Caputo AA, Holcomb J, Trabert KC. The retentive and stress-distributing properties of a threaded endodontic dowel. *J Prosthet Dent* 1980;44(4):398-404.
86. Sorensen JA, Martinoff JT. Clinically significant factors in dowel design. *J Prosthet Dent* 1984;52(1):28-35.

87. Asmussen E, Peutzfeldt A, Heitmann T. Stiffness, elastic limit, and strength of newer types of endodontic posts. *J Dent* 1999;27(4):275-8.
88. Dallari A, Rovatti L. Six years of in vitro/in vivo experience with Compositopost. *Compend Contin Educ Dent Suppl* 1996(20):S57-63.
89. Ferrari M, Mannocci F, Vichi A, Cagidiaco MC, Mjor IA. Bonding to root canal: structural characteristics of the substrate. *Am J Dent* 2000;13(5):255-60.
90. Ferrari M, Vichi A, Garcia-Godoy F. Clinical evaluation of fiber-reinforced epoxy resin posts and cast post and cores. *Am J Dent* 2000;13(Spec No):15B-18B.
91. Malferrari S, Monaco C, Scotti R. Clinical evaluation of teeth restored with quartz fiber-reinforced epoxy resin posts. *Int J Prosthodont* 2003;16(1):39-44.
92. Mannocci F, Innocenti M, Ferrari M, Watson TF. Confocal and scanning electron microscopic study of teeth restored with fiber posts, metal posts, and composite resins. *J Endod* 1999;25(12):789-94.
93. Thongthammachat S, Platt JA, Katona TR, Hovijitra S, Moore BK. Fracture resistance and fracture resistance after fatigue loading of 4 different post and cores in endodontically treated teeth. *Compend Contin Educ Dent* 2006;27(7):396-401; quiz 02, 21.
94. Leempoel PJ, van Rossum GM, de Haan AF, Reintjes AG. Types of patients with crowns in general dental practices. *J Oral Rehabil* 1987;14(6):623-9.
95. Eckerbom M, Magnusson T. Restoring endodontically treated teeth: a survey of current opinions among board-certified prosthodontists and general dental practitioners in Sweden. *Int J Prosthodont* 2001;14(3):245-9.
96. Morgano SM, Hashem AF, Fotoohi K, Rose L. A nationwide survey of contemporary philosophies and techniques of restoring endodontically treated teeth. *J Prosthet Dent* 1994;72(3):259-67.
97. Tinner D, Marinello C, Kerschbaum T. [The preprosthetic preparation of the endodontically treated abutment tooth. Post and core technique: a questionnaire analysis]. *Schweiz Monatsschr Zahnmed* 2001;111(4):402-9.
98. Watson RJ. The amalgam core. *J Prosthet Dent* 1968;19(5):500-5.
99. Newburg RE, Pameijer CH. Retentive properties of post and core systems. *J Prosthet Dent* 1976;36(6):636-43.
100. Perez Moll JF, Howe DF, Svare CW. Cast gold post and core and pin-retained composite resin bases: a comparative study in strength. *J Prosthet Dent* 1978;40(6):642-4.

101. Nealon FH, Sheakley HG. An extraoral pin technique. *J Prosthet Dent* 1969;22(6):638-46.
102. Tylman SD. *Theory and practice of crown and fixed partial prosthodontics*. 6th ed. St. Louis: C.V. Mosby Co.; 1970, p. 341-8.
103. Wang CS, Debelian GJ, Teixeira FB. Effect of intracanal medicament on the sealing ability of root canals filled with Resilon. *J Endod* 2006;32(6):532-6.
104. Williams C, Loushine RJ, Weller RN, Pashley DH, Tay FR. A comparison of cohesive strength and stiffness of Resilon and gutta-percha. *J Endod* 2006;32(6):553-5.
105. Shipper G, Orstavik D, Teixeira FB, Trope M. An evaluation of microbial leakage in roots filled with a thermoplastic synthetic polymer-based root canal filling material (Resilon). *J Endod* 2004;30(5):342-7.
106. Shipper G, Teixeira FB, Arnold RR, Trope M. Periapical inflammation after coronal microbial inoculation of dog roots filled with gutta-percha or resilon. *J Endod* 2005;31(2):91-6.
107. Aptekar A, Ginnan K. Comparative analysis of microleakage and seal for 2 obturation materials: Resilon/Epiphany and gutta-percha. *J Can Dent Assoc* 2006;72(3):245.
108. Bodrumlu E, Tunga U. Apical leakage of Resilon obturation material. *J Contemp Dent Pract* 2006;7(4):45-52.
109. Stratton RK, Apicella MJ, Mines P. A fluid filtration comparison of gutta-percha versus Resilon, a new soft resin endodontic obturation system. *J Endod* 2006;32(7):642-5.
110. Teixeira FB, Teixeira EC, Thompson JY, Trope M. Fracture resistance of roots endodontically treated with a new resin filling material. *J Am Dent Assoc* 2004;135(5):646-52.
111. Tay FR, Loushine RJ, Weller RN, et al. Ultrastructural evaluation of the apical seal in roots filled with a polycaprolactone-based root canal filling material. *J Endod* 2005;31(7):514-9.
112. Biggs SG, Knowles KI, Ibarrola JL, Pashley DH. An in vitro assessment of the sealing ability of Resilon/Epiphany using fluid filtration. *J Endod* 2006;32(8):759-61.
113. Bodrumlu E, Tunga U, Alacam T. Influence of immediate and delayed post space preparation on sealing ability of resilon. *Oral Surg Oral Med Oral Pathol Oral Radiol Endod* 2007;103(6):e61-4.
114. Kidd EA. Microleakage: a review. *J Dent* 1976;4(5):199-206.



115. Camp LR, Todd MJ. The effect of dowel preparation on the apical seal of three common obturation techniques. *J Prosthet Dent* 1983;50(5):664-6.
116. Raiden GC, Gendelman H. Effect of dowel space preparation on the apical seal of root canal fillings. *Endod Dent Traumatol* 1994;10(3):109-12.
117. DeCleen MJ. The relationship between the root canal filling and post space preparation. *Int Endod J* 1993;26(1):53-8.
118. Wu MK, Pehlivan Y, Kontakiotis EG, Wesselink PR. Microleakage along apical root fillings and cemented posts. *J Prosthet Dent* 1998;79(3):264-9.
119. Kvist T, Rydin E, Reit C. The relative frequency of periapical lesions in teeth with root canal-retained posts. *J Endod* 1989;15(12):578-80.
120. Fogel HM. Microleakage of posts used to restore endodontically treated teeth. *J Endod* 1995;21(7):376-9.
121. Saunders WP, Saunders EM. Coronal leakage as a cause of failure in root-canal therapy: a review. *Endod Dent Traumatol* 1994;10(3):105-8.
122. Bronson MR, Lindquist TJ, Dawson DV. Clinical acceptability of crown margins versus marginal gaps as determined by pre-doctoral students and prosthodontists. *J Prosthodont* 2005;14(4):226-32.
123. Cardash H, Shpreling I, Helft M. An aid to evaluating the marginal fit of full crowns. *Quintessence Int Report No. 1832*, January 1980:1.
124. Assif D, Antopolski B, Helft M, Kaffe I. Comparison of methods of clinical evaluation of the marginal fit of complete cast gold crowns. *J Prosthet Dent* 1985;54(1):20-4.
125. Brownlee K. *Statistical theory and methodology in science and engineering*. 2nd ed. New York: John Wiley & Sons, Inc; 1965.
126. Christensen G. Marginal fit of gold inlay castings. *J Prosthet Dent* 1966;16:197.
127. Karlsen K. Gingival reactions to dental restorations. *Acta Odontol Scand* 1970;28:895.
128. Loe H. Reaction of marginal periodontal tissue to restorative procedures. *Int Dent J* 1968;18:759.
129. Newcomb G. The relationship between the location of subgingival crowns margins, and gingival inflammation. *J Periodontol* 1974;45:151.
130. Richter W, Ueno H. Relationship of crown margins placement to gingival inflammation. *J Prosthet Dent* 1973;30:156.

131. Valdehaug J, Birkeland J. Periodontal consideration in patients 5 years following insertion of fixed prostheses. *J Oral Rehabil* 1976;3:237.
132. Waerhaug H. Justification for splinting in periodontal therapy. *J Prosthet Dent* 1969;22:201.
133. Waerhaug J. Histologic considerations which govern where the margins of restorations should be located in relation to the gingiva. *Dent Clin North Am* 1960;4:161.
134. Ayad MF. Compositional stability and marginal accuracy of complete cast crowns made with as-received and recast type III gold alloy. *J Prosthet Dent* 2002;87(2):162-6.
135. Eames WB, O'Neal SJ, Monteiro J, Miller C, Roan JD, Jr., Cohen KS. Techniques to improve the seating of castings. *J Am Dent Assoc* 1978;96(3):432-7.
136. Emtiaz S, Goldstein G. Effect of die spacers on precementation space of complete-coverage restorations. *Int J Prosthodont* 1997;10(2):131-5.
137. Grajower R, Zuberi Y, Lewinstein I. Improving the fit of crowns with die spacers. *J Prosthet Dent* 1989;61(5):555-63.
138. Passon C, Lambert RH, Lambert RL, Newman S. The effect of multiple layers of die-spacer on crown retention. *Oper Dent* 1992;17(2):42-9.
139. Rosenstiel SF, Gegauff AG. Improving the cementation of complete cast crowns: a comparison of static and dynamic seating methods. *J Am Dent Assoc* 1988;117(7):845-8.
140. Campagni WV, Wright W, Martinoff JT. Effect of die spacer on the seating of complete cast gold crowns with grooves. *J Prosthet Dent* 1986;55(3):324-8.
141. Marker VA, Miller AW, Miller BH, Swepston JH. Factors affecting the retention and fit of gold castings. *J Prosthet Dent* 1987;57(4):425-30.
142. Worley JL, Hamm RC, von Fraunhofer JA. Effects of cement on crown retention. *J Prosthet Dent* 1982;48(3):289-91.
143. A K. Casting techniques and some variables. *J Prosthet Dent* 1961;11:533-6.
144. Hollenback GM. A practical contribution to the standardization of casting technic. *J Am Dent Assoc* 1928;15:1917.
145. Jones MD, Dykema RW, Klein AI. Television micromasurement of vented and non-vented cast crown marginal adaptation. *Dent Clin North Am* 1971;15(3):663-77.

146. Pilo R, Cardash HS, Baharav H, Helft M. Incomplete seating of cemented crowns: a literature review. *J Prosthet Dent* 1988;59(4):429-33.
147. Olivera AB, Saito T. The effect of die spacer on retention and fitting of complete cast crowns. *J Prosthodont* 2006;15(4):243-9.
148. Grajower R, Lewinstein I. A mathematical treatise on the fit of crown castings. *J Prosthet Dent* 1983;49(5):663-74.
149. Reill MI, Rosentritt M, Naumann M, Handel G. Influence of core material on fracture resistance and marginal adaptation of restored root filled teeth. *Int Endod J* 2008;41(5):424-30.
150. Rosentritt M, Behr M, Gebhard R, Handel G. Influence of stress simulation parameters on the fracture strength of all-ceramic fixed-partial dentures. *Dent Mater* 2006;22(2):176-82.
151. Carossa S, Lombardo S, Pera P, Corsalini M, Rastello ML, Preti PG. Influence of posts and cores on light transmission through different all-ceramic crowns: spectrophotometric and clinical evaluation. *Int J Prosthodont* 2001;14(1):9-14.
152. Michalakakis KX, Hirayama H, Sfolkos J, Sfolkos K. Light transmission of posts and cores used for the anterior esthetic region. *Int J Periodontics Restorative Dent* 2004;24(5):462-9.
153. Quintas AF, Dinato JC, Bottino MA. Aesthetic posts and cores for metal-free restoration of endodontically treated teeth. *Pract Periodontics Aesthet Dent* 2000;12(9):875-84; quiz 86.
154. Abel MG. Metal-free dentistry. Restoration of congenitally missing lateral incisors. *Dent Today* 2005;24(9):114-7.
155. Donovan TE. Metal-free dentistry. *J Esthet Restor Dent* 2005;17(3):141-3.
156. Flesch B. [Esthetic dentistry with metal-free ceramic]. *Zahntechnik (Zur)* 1989;46(6):455-7.
157. John MP, Ronald LS. *Restorative dental materials*. 12th ed. St. Louis: Mosby, 2006.
158. Donovan TE. Metal-free dentistry: consumer generated or marketing hype? *J Esthet Restor Dent* 2002;14(2):71-3.
159. Stegaroiu R, Yamada H, Kusakari H, Miyakawa O. Retention and failure mode after cyclic loading in two post and core systems. *J Prosthet Dent* 1996;75(5):506-11.
160. Hu S, Osada T, Shimizu T, Warita K, Kawawa T. Resistance to cyclic fatigue and fracture of structurally compromised root restored with different post and core restorations. *Dent Mater J* 2005;24(2):225-31.

161. John MP, John CW. Restorative dental materials. 9th ed. St. Louis: Mosby, 1993. p. 256, 426.
162. Valadez ED. Evaluation of fracture resistance and retentive capability of four different posts on flared canals in endodontically treated teeth. [Thesis] Indianapolis: Indiana University School of Dentistry; 1997.
163. Fakiha ZA, Mueninghoff LA, Leinfelder KF. Rapid mixing of zinc phosphate cement for fixed prosthodontic procedures. *J Prosthet Dent* 1992;67(1):52-8.
164. Eckert GJ, Platt JA. A statistical evaluation of microtensile bond strength methodology for dental adhesives. *Dent Mater* 2007;23(3):385-91.
165. Chutinan S, Platt JA, Cochran MA, Moore BK. Volumetric dimensional change of six direct core materials. *Dent Mater* 2004;20(4):345-51.
166. Pearson GJ. Long term water sorption and solubility of composite filling materials. *J Dent* 1979;7(1):64-8.
167. Ohtsuka M. [Effects of margin designs on fracture strength and pattern of endodontically-treated teeth with no coronal tooth structure]. *Nihon Hotetsu Shika Gakkai Zasshi* 2005;49(1):74-83.
168. Sirimai S, Riis DN, Morgano SM. An in vitro study of the fracture resistance and the incidence of vertical root fracture of pulpless teeth restored with six post-and-core systems. *J Prosthet Dent* 1999;81(3):262-9.
169. Bjork A. The face in profile. *Svensk Tand Tias* 1948;40(5b):supplement.
170. Jung SH, Min KS, Chang HS, Park SD, Kwon SN, Bae JM. Microleakage and fracture patterns of teeth restored with different posts under dynamic loading. *J Prosthet Dent* 2007;98(4):270-6.
171. Freeman MA, Nicholls JI, Kydd WL, Harrington GW. Leakage associated with load fatigue-induced preliminary failure of full crowns placed over three different post and core systems. *J Endod* 1998;24(1):26-32.
172. Hsu YB, Nicholls JI, Phillips KM, Libman WJ. Effect of core bonding on fatigue failure of compromised teeth. *Int J Prosthodont* 2002;15(2):175-8.
173. Huysmans MC, Peters MC, Van der Varst PG, Plasschaert AJ. Failure behavior of fatigue-tested post and cores. *Int Endod J* 1993;26(5):294-300.
174. Yoshida K, Atsuta M. Effects of adhesive primers for noble metals on shear bond strengths of resin cements. *J Dent* 1997;25(1):53-8.
175. DeLong R, Douglas WH. An artificial oral environment for testing dental materials. *IEEE Trans Biomed Eng* 1991;38(4):339-45.

176. Lambrechts P, Vuylsteke, M, Vanherle, G, Davidson, CL Quantitative evaluation of the wear of posterior dental restorations: four-year results. *J Dent Res* 1985;65(special issue).
177. Garner LD, Kotwal NS. Correlation study of incisive biting forces with age, sex, and anterior occlusion. *J Dent Res* 1973;52(4):698-702.
178. Wegner PK, Freitag S, Kern M. Survival rate of endodontically treated teeth with posts after prosthetic restoration. *J Endod* 2006;32(10):928-31.
179. Loney RW, Kotowicz WE, McDowell GC. Three-dimensional photoelastic stress analysis of the ferrule effect in cast post and cores. *J Prosthet Dent* 1990;63(5):506-12.
180. Yaman SD, Alacam T, Yaman Y. Analysis of stress distribution in a maxillary central incisor subjected to various post and core applications. *J Endod* 1998;24(2):107-11.
181. Sorensen JA, Engelman MJ. Effect of post adaptation on fracture resistance of endodontically treated teeth. *J Prosthet Dent* 1990;64(4):419-24.
182. Grieznis L, Apse P, Soboleva U. The effect of 2 different diameter cast posts on tooth root fracture resistance in vitro. *Stomatologija* 2006;8(1):30-2.
183. Mattison GD. Photoelastic stress analysis of cast-gold endodontic posts. *J Prosthet Dent* 1982;48(4):407-11.
184. Del Castillo R, Ercoli C, Graser GN, Tallents RH, Moss ME. Effect of ring liner and casting ring temperature on the dimension of cast posts. *J Prosthet Dent* 2000;84(1):32-7.
185. Dilmener FT, Sipahi C, Dalkiz M. Resistance of three new esthetic post-and-core systems to compressive loading. *J Prosthet Dent* 2006;95(2):130-6.
186. Jung RE, Kalkstein O, Sailer I, Roos M, Hammerle CH. A comparison of composite post buildups and cast gold post-and-core buildups for the restoration of nonvital teeth after 5 to 10 years. *Int J Prosthodont* 2007;20(1):63-9.
187. Segerstrom S, Astback J, Ekstrand KD. A retrospective long term study of teeth restored with prefabricated carbon fiber reinforced epoxy resin posts. *Swed Dent J* 2006;30(1):1-8.
188. Forberger N, Gohring TN. Influence of the type of post and core on in vitro marginal continuity, fracture resistance, and fracture mode of lithia disilicate-based all-ceramic crowns. *J Prosthet Dent* 2008;100(4):264-73.
189. Toparli M. Stress analysis in a post-restored tooth utilizing the finite element method. *J Oral Rehabil* 2003;30(5):470-6.

190. Cohen BI, Pagnillo M, Condos S, Musikant BL, Deutsch AS. Comparison of the photoelastic stress properties for two combination prefabricated cast post systems. *Oral Health* 1995;85(8):41-4, 46.
191. Isidor F, Brondum K. Intermittent loading of teeth with tapered, individually cast or prefabricated, parallel-sided posts. *Int J Prosthodont* 1992;5(3):257-61.
192. Barkmeier WW, Latta MA. Laboratory evaluation of a metal-priming agent for adhesive bonding. *Quintessence Int* 2000;31(10):749-52.
193. Osman SA, McCabe JF, Walls AW. Polymerisation shrinkage of luting agents for crown and bridge cementation. *Eur J Prosthodont Restor Dent* 2008;16(1):39-44.
194. Li HL, Liu D, Bi XQ, et al. [Influence of hand-mixed methods on compressive strength of zinc phosphate dental cement]. *Hua Xi Kou Qiang Yi Xue Za Zhi* 2008;26(2):172-4.

APPENDIXES

## APPENDIX I

Group CP individual fatigue loading marginal gap data (microns)

<u>Tooth #</u>	<u>Facial gap</u> <u>before test</u>	<u>Facial gap</u> <u>after test</u>	<u>Lingual gap</u> <u>before test</u>	<u>Lingual gap</u> <u>after test</u>	<u>Cycles</u> <u>completed</u>
01	N/A	N/A	N/A	N/A	0***
02	5	36	18	72	100,000
03	5	N/A	6	N/A	0**
07	7	36	21	122	100,000
08	N/A	N/A	N/A	N/A	0***
12	13	10	10	21	100,000
14	14	36	28	82	100,000
30	6	30	7	26	65,400*
32	37	32	6	15	100,000
38	14	N/A	4	N/A	0**

\* Fractured during testing

\*\* Failed to test due to root curvature

\*\*\* Root split before crown cementation



## APPENDIX II

Group FR individual fatigue loading marginal gap data (microns)

<u>Tooth #</u>	<u>Facial gap</u> <u>before test</u>	<u>Facial gap</u> <u>after test</u>	<u>Lingual gap</u> <u>before test</u>	<u>Lingual gap</u> <u>after test</u>	<u>Cycles</u> <u>completed</u>
15	35	17	53	61	100,000
17	15	15	35	56	100,000
19	11	6	37	45	100,000
20	18	16	24	25	100,000
22	20	15	33	34	100,000
23	82	83	43	45	100,000
24	24	18	63	78	100,000
25	33	33	82	127	100,000
26	9	17	34	57	100,000
27	18	10	93	114	100,000

## APPENDIX III

Group MR individual fatigue loading marginal gap data (microns)

<u>Tooth #</u>	<u>Facial gap</u> <u>before test</u>	<u>Facial gap</u> <u>after test</u>	<u>Lingual gap</u> <u>before test</u>	<u>Lingual gap</u> <u>after test</u>	<u>Cycles</u> <u>completed</u>
29	4	5	62	352	100,000
31	11	11	38	99	100,000
33	41	40	44	98	100,000
34	4	8	51	66	16,500*
35	42	48	51	91	100,000
36	77	121	119	152	100,000
37	28	30	15	120	100,000
39	70	N/A	53	N/A	45,120*
41	10	26	15	141	100,000
42	71	N/A	10	N/A	0*

\* Fractured during testing

## APPENDIX IV

Individual load-to-failure strength data of the post systems (Newtons)

<u>Tooth #</u>	<u>Group CP</u>	<u>Tooth #</u>	<u>Group FR</u>	<u>Tooth #</u>	<u>Group MR</u>
43 A	1623	54 A	455	68 M	1958
44 A	1862	55 JMA	1090	69 A	702
45 JMA	1123	57 JMA	681	71 M	1211
46 JMA	1240	58 JMA	1720	72 A	1569
47 A	1186	59 M	1633	74 M	975
48 A	1460	61 M	1160	75 M	1769
49 JMC	1283	62 M	801	77 M	1377
51 A	2162	63 JMA	1878	78 JMA	1234
52 JMA	1251	64 JMA	1843	79 M	1976
53 JMA	899	67 A	877	81 M	1553

Fracture site:

C: Cervical third

JMC: Junction of middle and cervical thirds

M: Middle third

JMA: Junction of middle and apical thirds

A: Apical third

## APPENDIX V

Group CP moment of inertia at cervical area ( I ) and fracture site ( I' )

<u>Tooth #</u>	<u>I</u>	<u>I'</u>
43	1642	73
44	1673	81
45	2373	520
46	1396	173
47	1783	147
48	1539	30
49	1022	549
51	2150	23
52	2481	179
53	1975	312

## APPENDIX VI

Group FR moment of inertia at cervical area ( I ) and fracture site ( I' )

<u>Tooth #</u>	<u>I</u>	<u>I'</u>
54	840	15
55	1595	27
57	2868	310
58	2591	129
59	1828	447
61	1917	520
62	996	178
63	2416	302
64	2564	630
67	1418	148

## APPENDIX VII

Group MR moment of inertia at cervical area ( I ) and fracture site ( I' )

<u>Tooth #</u>	<u>I</u>	<u>I'</u>
68	1923	544
69	1963	179
71	1287	410
72	1986	73
74	970	117
75	3407	953
77	2560	582
78	2219	208
79	1932	821
81	1898	425

ABSTRACT

EVALUATION OF FRACTURE RESISTANCE OF THREE POST AND CORE  
SYSTEMS IN ENDODONTICALLY TREATED TEETH UNDER  
LOADING TO FAILURE; AND MARGINAL GAP  
MEASUREMENT BEFORE AND AFTER  
CYCLIC LOADING

by

Amir N. Saad

Indiana University School of Dentistry  
Indianapolis, IN

The purpose of this study was to evaluate the fracture resistance of three post and core systems in endodontically treated teeth by loading to failure, and to measure marginal gaps before and after cyclic loading.

Sixty extracted canines were assigned to three groups. The groups tested were:

- 1) Single cast post and core (Group CP).
- 2) Prefabricated metal post and composite resin core (Group MR).
- 3) Glass fiber post and composite resin core (Group FR).



All teeth were obturated and prepared to receive a post and core with a coping. Thirty teeth (10 from each group) were loaded to failure, and the other 30 teeth were fatigue-loaded. The marginal gaps on the facial and lingual surface of the fatigue-loaded group were measured before and after cyclic loading.

There were two hypotheses for this study. The first was that the FR group would have less marginal gap opening on the lingual surface than the other groups. The second was that the CP group would have a higher load at failure than the other groups.

Group CP was found to have a significantly smaller pre-loading marginal gap than group FR ( $p = 0.0265$ ) and group MR ( $p = 0.0273$ ), while groups FR and MR did not have a significantly different pre-loading marginal gaps ( $p = 0.86$ ). Group FR had significantly less change in marginal gap than group MR ( $p = 0.0013$ ). Groups CP and MR did not have significantly different changes in marginal gap ( $p = 0.09$ ). Groups CP and FR did not have significantly different changes in marginal gap ( $p = 0.11$ ). The three post types did not have significantly different maximum loads to failure ( $p = 0.49$ ), moments of inertia at cervical area ( $p = 0.75$ ), or moments of inertia at fracture site ( $p=0.12$ ).

There was no significant difference between groups CP, FR, and MR in the load-to-failure test. Group CP demonstrated the highest load-to-failure values; however, the highest load-to-failure mean was for group MR. All fractures observed in this study were catastrophic. Group FR demonstrated better stress distribution and caused no early fractures in the fatigue-loading group.

All groups demonstrated significant marginal gap changes on the lingual surface after fatigue loading; however, group FR demonstrated  $<45 \mu\text{m}$  marginal gap opening. In group FR, the reduced marginal gap opening was attributed to the use of

Panavia 21 with the proper surface treatments to bond to the tooth structure, the resin composite, and the metal coping.

## CURRICULUM VITAE

Amir N. Saad

November 22, 1979	Born in Stonewall, Manitoba, Canada
September 1998 – July 1999	Faculty of Science, Cairo University
September 1999 – May 2002	BDS, Faculty of Oral and Dental Medicine, Cairo University, Cairo, Egypt
November 2002 – April 2003	Internship in El Mounira Hospital
April 2003 – November 2003	Internship in Cairo University, Faculty of Oral and Dental Medicine
November, 2008	MSD Program, Prosthodontics Indiana University School of Dentistry Indianapolis, Indiana