

**STUDY OF CONNECTIVITY PROBABILITY IN VANETS BY
A TWO-DIMENSIONAL PLATOON-BASED MODEL**

by
Donglin Liu

A Thesis

Submitted to the Faculty of Purdue University

In Partial Fulfillment of the Requirements for the degree of

Master of Science

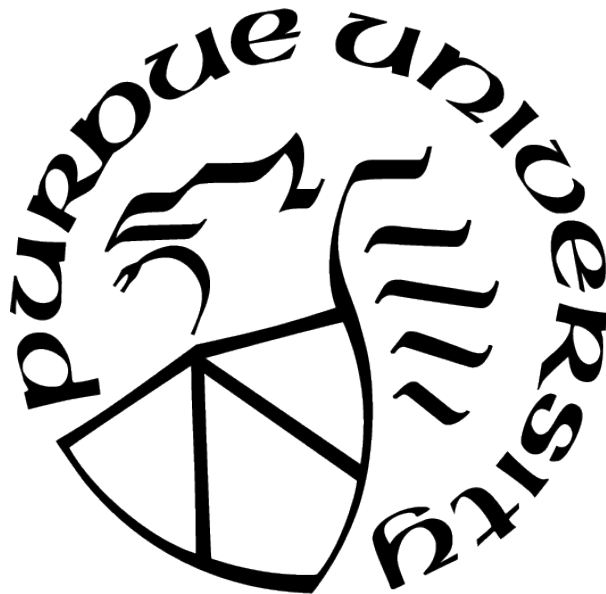

Department of Electrical and Computer Engineering

Indianapolis, Indiana

August 2021

**THE PURDUE UNIVERSITY GRADUATE SCHOOL
STATEMENT OF COMMITTEE APPROVAL**

Dr. Lingxi Li, Chair

Department of Electrical and Computer Engineering

Dr. Yaobin Chen

Department of Electrical and Computer Engineering

Dr. Brian King

Department of Electrical and Computer Engineering

Approved by:

Dr. Brian King

Dedicated to my family, friends and my Professors, for their support and encouragement.

ACKNOWLEDGMENTS

Firstly, I would like to thank Dr. Lingxi Li for his support. The research work of my thesis is completed by the patient guidance and direction of Dr. Li. He has been a wonderful advisor and helped me a lot in my academic journey. I would also like to thank Dr. Yaobin Chen, whose course on automatic vehicles gave me inspiration of writing this thesis. I greatly thank to Dr. Brian King, who provided suggestions of course selection when I was a new student and took out of his busy schedule to be a part of my advisor committee. A special thanks to Dr. Chien, who led me to accomplish my project. I would like to thank Ms. Sherrie Tucker for assistance throughout my Master program.

Last but not least, I would like to thank my parents for their encouragement and my friend Dan Shen, who is a talented PhD student and experienced researcher, for his suggestions on my research work.

TABLE OF CONTENTS

LIST OF TABLES	7
LIST OF FIGURES	8
LIST OF SYMBOLS	10
ABBREVIATIONS	11
ABSTRACT	12
1 INTRODUCTION	13
1.1 Motivation	13
1.2 Literature review	14
1.3 Thesis contributions	15
1.4 Thesis organization	16
2 VANETS AND PLATOON	17
2.1 Introduction of MANETs	17
2.2 Introduction of VANETs	18
2.2.1 V2V communication	18
2.2.2 V2I communication	20
2.2.3 Relationship between V2V and V2I	21
2.3 Introduction of platoon	22
2.3.1 Description of platoon	22
2.3.2 Cooperative adaptive cruise control	23
2.3.3 Topology of platoon	24
2.3.4 Security distance	26
2.3.5 Communication range	27
3 PLATOON-BASED MODEL	29
3.1 Implementation of the platoon-based model	29
3.2 Connectivity probability analysis in LF platoon model	31
3.3 BD topology platoon model	40
3.4 Two ways BD platoon based model	46
3.5 Summary	48

4	SIMULATION AND RESULTS	49
4.1	Results of 5 original cases	49
4.2	Connectivity probability with different ratio of platoon	52
4.3	Connectivity probability with different coverage gap	53
4.4	Connectivity probability with different lanes	54
4.5	Results of BD platoon based model	56
4.6	Relations between two platoons	59
4.6.1	Communication ranges and length of platoon relations	59
4.6.2	Performance in two-ways scenario	61
5	CONCLUSION AND FUTURE WORKS	62
5.1	Conclusion	62
5.2	Future works	63
	REFERENCES	64

LIST OF TABLES

4.1	All parameter values for 5 original cases	49
4.2	All parameter values for different ratio of platoon cases	52
4.3	All parameter values for different ratio of platoon cases	53
4.4	All parameter values for different intervals of BSs cases	54
4.5	All parameter values for different intervals of BSs cases	56
4.6	All parameter values for different intervals of BSs cases	59
4.7	All parameter values for different intervals of BSs cases	61

LIST OF FIGURES

2.1	Example of ad hoc network.	17
2.2	Example of V2V communication[14]	19
2.3	Example of V2I communication[15]	20
2.4	Example of VANETs with both technologies[18]	21
2.5	Example of platoon[21]	22
2.6	Information flow with CACC[23]	23
2.7	Cooperative adaptive cruise control	24
2.8	7 types of typologies	25
2.9	Security distance and distance error	26
2.10	Communication range	27
3.1	angle =90	30
3.2	Coverage gap	31
3.3	Case a: $d \leq 0$	32
3.4	Case b: $0 < d \leq R_1$	33
3.5	Case b: $R_1 \leq d \leq R_2 < 2R_1$	34
3.6	Case b: 2 lanes scenario	35
3.7	Case d: Blind area	38
3.8	Case d: Connected via one hop	38
3.9	Case b: $L < d \leq 2L$	41
3.10	Case c: $2L < d \leq 2L + R_1$	42
3.11	Case d: $2L + R_1 < d \leq 3L + R_1$	43
3.12	Case e: $3L + R_1 < d \leq 2R_1 + 3L$	45
3.13	Case f: $d > 2R_1 + 3L$	46
3.14	Case c: Two lanes scenario	47
4.1	Overall connectivity probability	50
4.2	Connectivity probability of individual vehicles in coverage gap	51
4.3	Connectivity probability of platoons in coverage gap	51
4.4	Overall connectivity probability with different ratio of platoon	52

4.5	Overall connectivity probability with different intervals of BSs	54
4.6	Overall connectivity probability with different number of lanes	55
4.7	$d=150\text{m}$	56
4.8	$d=400\text{m}$	57
4.9	$d=550\text{m}$	57
4.10	$d=800\text{m}$	58
4.11	$d=1500\text{m}$	58
4.12	Relationship of L and R_2	60
4.13	Relationship of R_1 and R_2	60
4.14	Connectivity probabilities of LF and BD platoon at minor lane	61

LIST OF SYMBOLS

d	distance of coverage gap
L	length of platoon
l	length of the highway
p	ratio of platoon
P	connectivity probability
R_1	communication rang of individual vehicles
R_2	communication rang of platoon
R_b	communication rang of base station
R_d	distance between two base stations
X	number of individual vehicles
Y	number of platoons
ρ	traffic density

ABBREVIATIONS

ACC	Adaptive cruise control
BS	Base station
BD	Bidirectional
BDL	Bidirectional-leader
CACC	Cooperative adaptive cruise control
ITS	Intelligent transportation systems
LF	Leader following
MANETs	Mobile ad hoc networks
PF	Predecessor following
PLF	Predecessor-leader following
RSUs	Road side units
TPF	Two-predecessors following
TPLF	Two-predecessor-leader following
VANETs	Vehicular ad hoc networks
V2I	Vehicle to infrastructure
V2V	Vehicle to vehicle
WLAN	Wireless local area network

ABSTRACT

With the fast development of 5G networks and the advancement in networking technologies, more and more new technologies such as internet of vehicles (IoV) is catching our eyes. With technologies of artificial intelligence and automatic control, IoV is transformed into an intelligent transportation system (ITS). The object of this thesis is to analyze the connectivity probability issues in vehicle ad hoc networks (VANETs), which is a subset of ITS. This will be achieved by a platoon-based two dimensional model. In order to make the results more accurate and more close to real scenario, different situations will be analyzed separately, and different types of platoon will be included. In addition, other system parameters are also discussed and stimulated. The results show that many parameters like the increases of traffic density, ratio of platoon, and lane numbers will improve connectivity probability. No-leader based platoons are easier to connect to the base stations compared to leader based platoons.

1. INTRODUCTION

As the number of cars increases year by year, more people choose to travel by cars. The networks of vehicles are needed to be built to provide drivers traffic information. VANET is a representative of networks of vehicles to exchanges information between vehicles and vehicles, as well as vehicles and infrastructure.

VANET is a particular case of wireless multi-hop network, which has the constraint of fast topology changes due to the high node mobility. VANETs support a wide range of applications, for example, prevention of collisions, safety, blind crossing, dynamic route scheduling, real-time traffic condition monitoring. Two main transmission methods in VANETs are V2V and V2I. One typically example of VANETs is platoon, which allows vehicles to closely follow a leading vehicle by wirelessly receiving acceleration and steering information, thus forming a "road trains". Platoon is an effective way to solve traffic congestion problem and reduce energy consumption. Connectivity is an important factor to measure the quantity of VANETs. In [1], the authors evaluate strategies for organizing vehicles into platoons and analyze that the ratio of platoon in highway can reach 80% with random grouping. This implies that study of connectivity in a platoon included VANET has been one of main point in internets of vehicles area.

This thesis is focused on building a platoon based VANETs 2-dimensional model with two types of platoon to analyze the connectivity probability in a mixed scenario for individual vehicles and platoons.

1.1 Motivation

With the continuous improvement of the industry, intelligent transportation systems (ITS) are developing rapidly, more and more transportation systems will be developed with the direction of ITS in the future [2]. As an important role in ITS, VANETs provide a safety and relaxing driving environment for drivers. However, the high speed of vehicles results in a rapid change in the network topology. limited transmission range of base stations (BSs) leads to a frequently connection switches. Both of them make the connection of the communication link change dynamically [3]. Consequently, as an effective way to arrange high

speed vehicles, platoon is deserved to be studied. Thesis seeks to make a small contribution to the field of VANETs by finding the relationships between connectivity probability and system parameters in VANETs.

1.2 Literature review

The authors in [4] derive some connectivity properties of VANETs in highway scenarios. In this paper, the object of study is individual vehicle. It is assumed that k vehicles locate in one interval with poison distribution. The connectivity probability is calculated in two ways: k nodes scenario and fixed node scenario. [5] also studies k -connectivity probability in one-dimensional linear networks. A helpful result is given that the communication range of individual vehicle should be larger than the sum of any k consecutive spacing.

As vehicles receive information from infrastructure, the distribution of it need to be considered. In [6], a one dimensional highway model with road side units (RSUs) is proposed to analyze the influence of the distance between two RSUs on connectivity probability. Objects are two types of individual vehicle with different communication ranges. Connection can be achieved by two hops. By choosing 3 coverage gap distances in terms of relations between it and two communication ranges, functions of connectivity probability are derived separately. Simulations are carried out with a continuous length of distance and outcome shows that connectivity probability suffers a significant decrease when coverage gap distance exceed the shorter communication range. This model is also able to be used in analyzing the ratio of different types vehicles and traffic density.

In recent years, more significant parameters such as safety distance and weather condition, are considered [7], [8]. In these papers, safety distance is a key parameter in VANET when the vehicle has a low communication range. Rainy days, snow and ice weather conditions will have influence on VANET by changing the electromagnetic properties of the road surface, resulting in a change in the reflection path.

Platoon, as one type of VANET, can be a sub-network in a large VANET mixed with individual vehicles. In [9], researchers build a speed-density-flow analytical model based on platoon to study connectivity in VANETs. In this model, by using control variable method,

an accurate relationship between 3 parameters and connectivity probability is given. The only drawback in this thesis is that the model is in one-dimensional, whereas, on real highway, usually there are more than 3 lanes in one direction. The authors in [10] provide a platoon-based model to study the connectivity probability for V2V and V2I scenarios respectively with same system parameters. The analysis shows that increasing the ratio of platoon will increase the connectivity probability in both scenarios, and the changes of system parameters is more likely to influence V2I scenario. A two-way highway scenario is considered in [11]. Vehicles in this scenario follow a Gaussian distribution, the article first calculate the disconnected probability in a major lane, then find the connectivity probability in a minor lane by using convolution integral. Security distance between platoon members is discussed to make the result more accurate. Drawbacks of this paper are the distance of two lanes is ignored, and only one type of platoon is considered.

1.3 Thesis contributions

The thesis analyzes the connectivity probability of VANETs using a platoon-based two-dimensional model, which includes two types of platoon. The main contributions of the thesis are itemized below:

- Designed the horizontal part of the platoon-based model in one way highway scenario
- Designed the vertical part of the platoon-based model in multiple lanes highway scenario
- Consider 5 situations of LF platoon in terms of different system parameters
- Consider 6 situations of BD platoon in terms of different system parameters
- Created and simulated various scenarios to find the results
- Find relationships between two types of platoon
- Provide ideal system parameters choices according to simulation results

1.4 Thesis organization

This thesis consists of five chapters. Chapter 1 is the motivation and literature review. This chapter discusses current trends and inspirations in VANETs. It talks about two main technologies and applications in VANETs. A brief introduction of platoon is also in this chapter. Chapter 2 introduces the background of VANETs and platoon, provides their features and gives the corresponding explanations. In Chapter 3, connectivity probabilities of different scenarios will be analyzed. This chapter also discuss vertical part of the platoon-based model. Two types of platoon based model are analyzed separately. Relationships between them are discussed in the last part of Chapter 3. Chapter 4 shows the simulation results based on the analysis in Chapter 3. Extensions are made to find accurate relationship between system parameters and connectivity probability in VANETs. The last chapter is conclusion and future work.

2. VANETS AND PLATOON

Although Vehicular Ad-hoc Network is not a new topic, many new problems have been proposed in recent years. The concept of VANET was first mentioned in 2001. In [12], VANETs is introduced to be one type of mobile ad hoc networks (MANETs). It can use any wireless networking technology as its basis, such as wireless LAN (WLAN), long-term evolution and visible light communication. Platoon can be seen as an ad hoc network consists of several vehicles, which have same speeds, accelerations, and intervals. As a necessary part of automated highway system, platoon is good at long distance travel. Drivers in platoon do not need to focus on driving for a long time, instead, can enjoy a relaxing time during the journey. It also allows the road to carry more cars.

2.1 Introduction of MANETs

MANETs are self-organizing and adaptive, which allow spontaneous formation and deformation of mobile networks. Figure 2.1 is an example of ad hoc network.

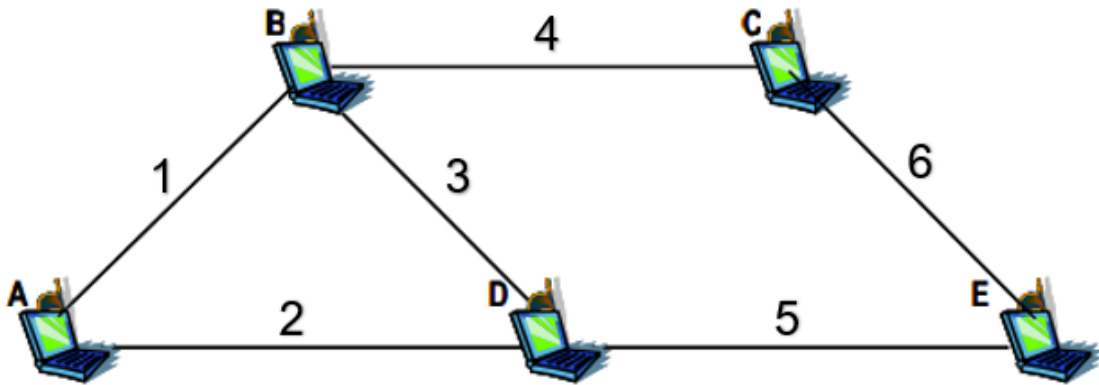

Figure 2.1. Example of ad hoc network.

This figure depicts a peer-to-peer multi-hop ad hoc network. Mobile node A can communicate with B when channel 1 is available. If channel 1 does not work, then multi-hop communication is necessary, e.g., A-D-B is one-hop communication, here node D acts as a router to transfer information from A to B.

Each node in an ad hoc network has its own characteristics, such as different speed and uniformity of mobility. Due to this mobility characteristic, the central nodes cannot always be relied on. When this happens in a wireless managed network, the node gets disconnected until it is in the coverage of central nodes again. Thus, the decentralized nature of ad hoc networks makes them suitable for a variety of applications compared to the wireless managed network. However, since we are breaking a managed network and replace it with a random one, the following problems appear:

- Link changes are happening quite often due to moving routers
- Packet losses due to transmission errors
- Event updates are sent often – a lot of traffic control
- How to find the shortest path (least number of nodes)

Designing a MANET not only needs to consider the challenges above, but also needs to find the mobility pattern. For example, the density and average speed of vehicles on highway in Indiana are different from those in California. These system parameters are also important in a MANET.

2.2 Introduction of VANETs

If the studied object is vehicle, MANETs change to VANETs. The vehicular communication system is formed by two main types of communications: V2V and V2I.

2.2.1 V2V communication

V2V communication (e.g., Figure 2.2) enables vehicles to wirelessly exchange information about their speed, location, and heading. It helps reduce the traffic accidents and improve traffic efficiency. Applications of V2V communication are studied in [13]:

- Lane change assistance: The risk of lateral collisions for vehicles that are approaching road intersections is detected by vehicles, risk information is transferred as signal to nearby vehicles in same ad hoc networks.

- Lane change assistance: Reducing the risk of switching a lane with a blind spot problem.
- Traffic condition warning: Once the traffic evolution is detected by any vehicle, it will share this information with other vehicles.
- Other vehicle capabilities: vehicle interfaces for sensors and radars, vehicle navigation capabilities.



Figure 2.2. Example of V2V communication[14]

Ad hoc network is very suitable for these issues as they have the same characteristics of temporary and localization. Compared to highway, V2V communication is more seen in local road. Complex road geometry, frequently lane changing and more obstacles on the road result in a high risk of lateral collisions.

2.2.2 V2I communication

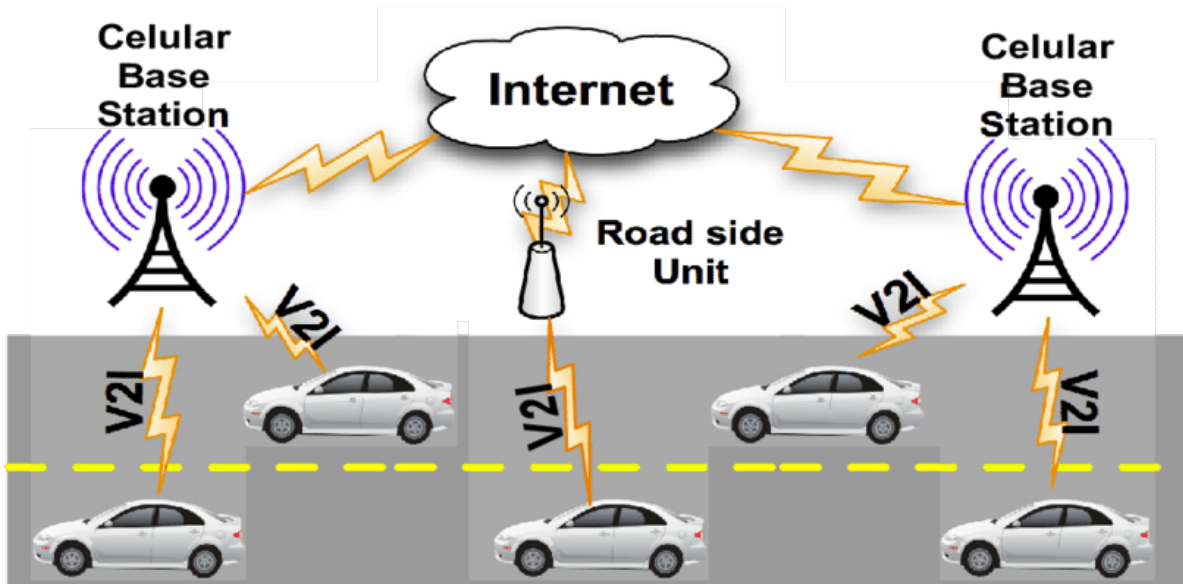

Figure 2.3. Example of V2I communication[15]

V2I is another type of communication method in VANETs. Vehicles can connect to BSs or road side units when they are in the transmission ranges of those infrastructures. Then infrastructures and road side units connect to internet through cables. With ultra-density BS coverage, we make sure that all cars on the road are connected together. The authors in [16] use downlink scheduling strategies to show that emergency message can be broadcasted efficiently in a large area by the infrastructures if the traffic density is at a low level. In other words, V2I communication is more appropriate to be applied in rural area, especially on the highway, vehicles with high speed and long intervals can relay on the BS to connect to internet. Applications of V2V communication are provided in [17]:

- Act as agencies with operational sensors: The infrastructures cooperative with traffic management agencies to provide information like temperature, humidity, wind speed and weather to drivers.

- Vehicle Classification Systems: These infrastructures are able to measure vehicles that exceed a certain dimensional threshold and help determine whether they may impact bridges or tunnels with low or narrow clearances.

2.2.3 Relationship between V2V and V2I

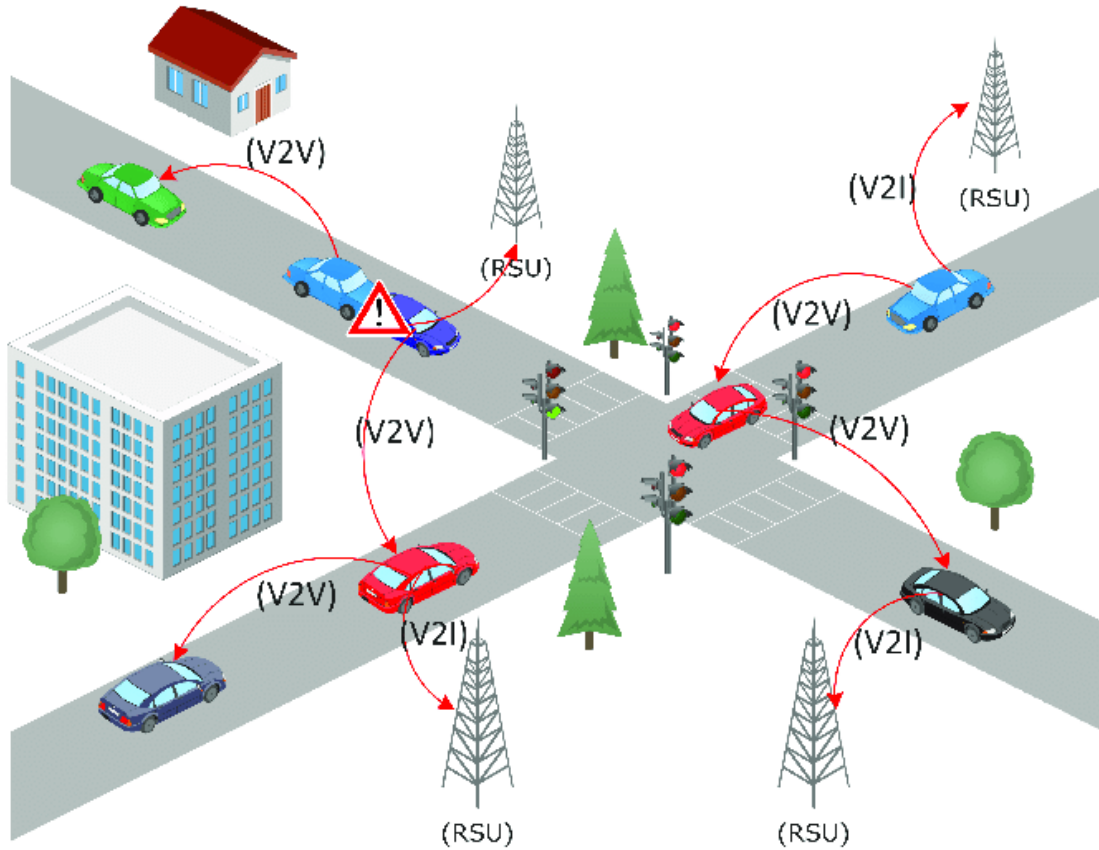

Figure 2.4. Example of VANETs with both technologies[18]

We cannot only talk about V2V or V2I without another one. In urban area, although V2V will increase traffic efficiency, the infrastructures are necessary. Figure 2.4 is an example of VANET contains both technologies. The BSs in urban area can provide vehicles with passengers' information when they are connected via mobile devices. On the other hand, as its hard to make the BSs cover everywhere, some vehicles cannot directly connect to the

infrastructures, in this situation, a V2V communication is needed. Vehicles in BSs' coverage will act as hops to communicate with both side, which will be discussed in next chapter.

2.3 Introduction of platoon

The beginning of platoon can be traced back to 1973, a European ARAMIS project platooned 25 small transit vehicles running a foot apart at 50 mph on a French test track. The vehicles used ultrasonic and optical range sensors [19]. At that time, intelligent technologies did not come into our eyes. Actually, those trucks were not connected, they just tried to keep consistent with then sensors. However, the idea of that project is like nowadays platoons.

2.3.1 Description of platoon

Several vehicles (commonly are trucks) forms an organized platoon with short intervals via cooperative adaptive cruise control (CACC)[20]. With CACC, the lead vehicle is wireless connected to following vehicles and sending messages that affect throttle, brakes (see Figure 2.5).

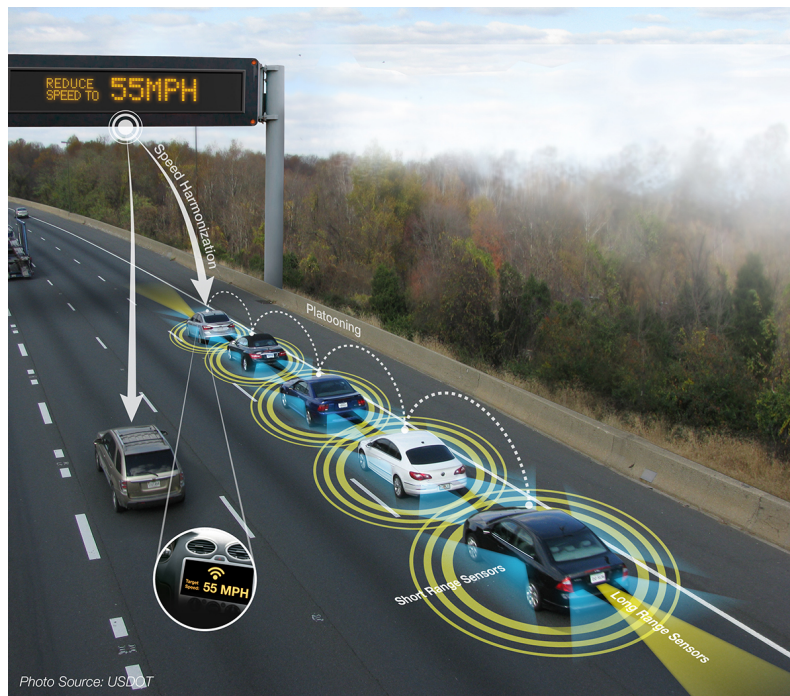

Figure 2.5. Example of platoon[21]

Benefits of platoon:

- Fuel economy: Air resistance is reduced by front vehicles, number of acceleration or deceleration operations will be less.
- Reduced congestion: Limited space carries maximum number of vehicles.
- Reduced human cost: Drivers do not need to focus on driving, or even do not need to be in the vehicle.

2.3.2 Cooperative adaptive cruise control

Adaptive cruise control (ACC) is a radar-based system, which is designed to enhance driving comfort and convenience by relieving the driver of the need to continually adjust his speed to match that of a preceding vehicle. Cooperative adaptive cruise control (CACC) is an extension of ACC by introducing V2V communication technology to the system. With CACC, platoon members will have a better understand of the state of other vehicles, information flow will be more smoothly [22].

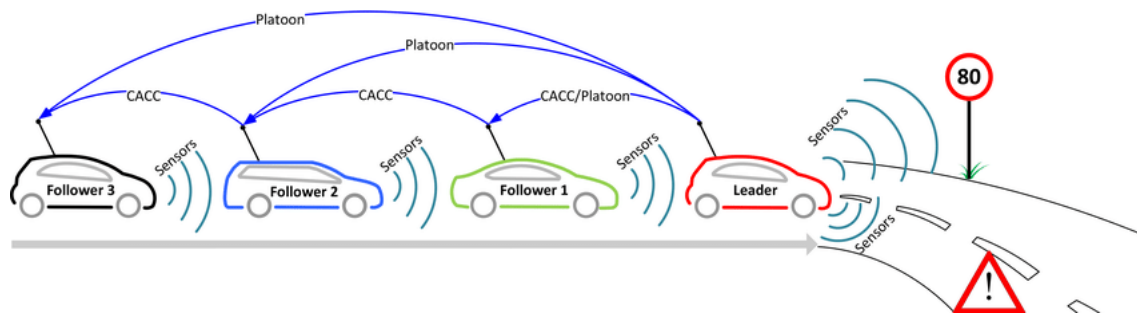

Figure 2.6. Information flow with CACC[23]

The CACC module communicates with several units to control the status of the vehicle, such as brake/throttle units (example: ABS brake system), on board sensors and driver/vehicle interface. The special unit in CACC is the V2V communication unit.

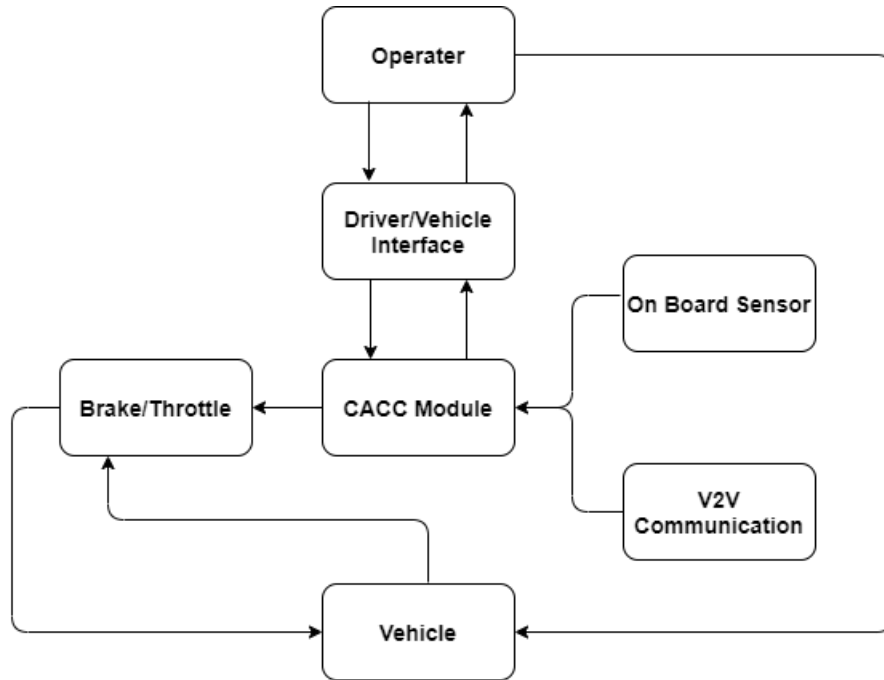

Figure 2.7. Cooperative adaptive cruise control

2.3.3 Topology of platoon

As part of VANETs, platoon is not simply connected randomly. Each platoon follows a certain pattern, which is the topology of platoon. Common topologies in platoon are:

- Leader following (LF) topology
- Predecessor following (PF) topology
- Predecessor-leader following (PLF) topology
- Bidirectional (BD) topology
- Bidirectional-leader (BDL) topology
- Two-predecessors following (TPF) topology
- Two-predecessor-leader following (TPLF) topology

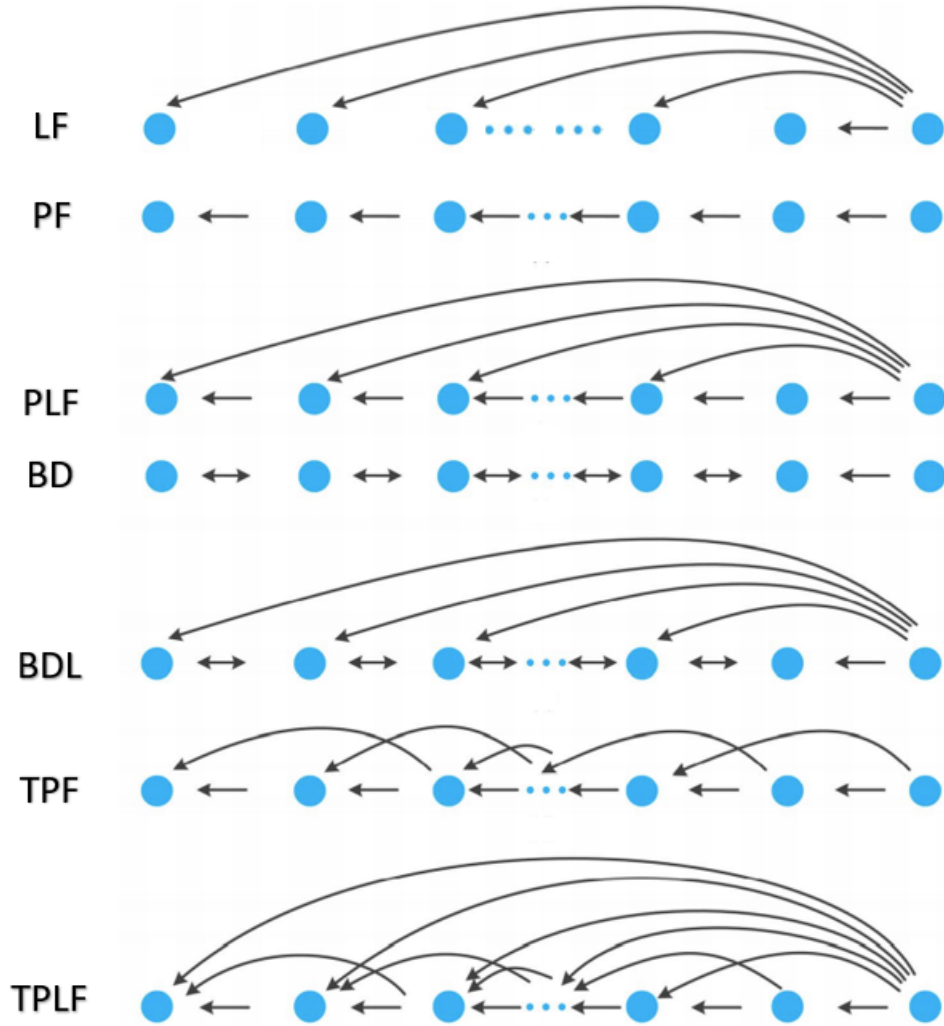

Figure 2.8. 7 types of typologies

Figure 2.6 shows the information flow of each type of topology. It can be observed that platoon types are divided into 2 parts: leader based, and no-leader based platoon. In a leader-based platoon, the following members are not required to deliver message. For example, in LF platoon, only the leader vehicle delivers messages to all members. The benefits of this type of topology are less time delay and less packets loss. All vehicles will follow the same instructions. The drawback of LF topology is the tolerance of disturbance is poor. Once any member receives wrong instructions, accidents are easy to happen as it is unable to communicate with nearby vehicles. If communications between member vehicles are available (e.g., PLF), the disturbance will be lessened.

For no-leader based platoon (e.g., BD), the information flow is reduced compared to PLF platoon and we do not need high quality leader vehicles, but this brings about a high time delay. When another vehicle wants to merge to the platoon, it needs to connect to the neighbor vehicles in the platoon as no leader vehicle is available. With transmission time delay, the merging action in this BD platoon costs more time than leader-based platoon.

2.3.4 Security distance

To avoid rear-end collisions, platoon members need to keep distance with neighbor vehicles. A constant distance policy is used in a platoon in common, which is called security distance. Many thesis ignore the security distance in platoon, they treat the platoon as an ideal point. [24] compares the connectivity probability with and without security distance. After introducing security distance, probability will decrease as the effective communication range will decrease. This policy is more suitable for LF platoon, it has been proven to yield better string stability performance with a security distance in a LF platoon [25]. Reference [25] introduced security distances to LF and PF platoons, and results show that string instabilities arise due to constraint on complementary sensitivity integral. Also in [26], the comparison between BD and LF platoon show that the stability of former one is influenced by security distance more.

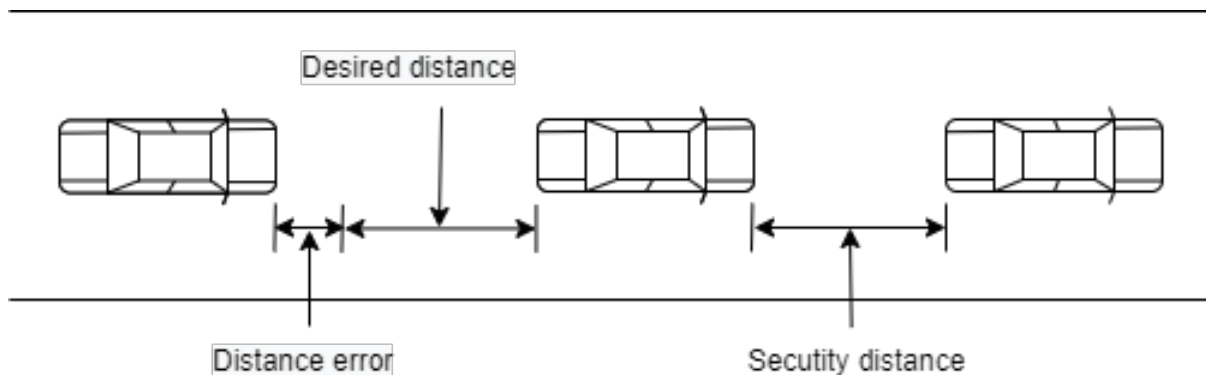

Figure 2.9. Security distance and distance error

Distance error occurs when disturbance or package loss happens in platoon. In LF pla-

toon, if response time of all platoon members is same, vehicles can follow a pre-determined velocity changes policy to make sure space between vehicles is not changed as they can not communicate with each other. In BD platoon, a fixed security distance policy is used to shorten the distance error.

2.3.5 Communication range

Communication range is a key parameter to measure platoon. Let R_1 and R_2 denote the communication range of platoon member and platoon leader. Let L be the length of platoon.

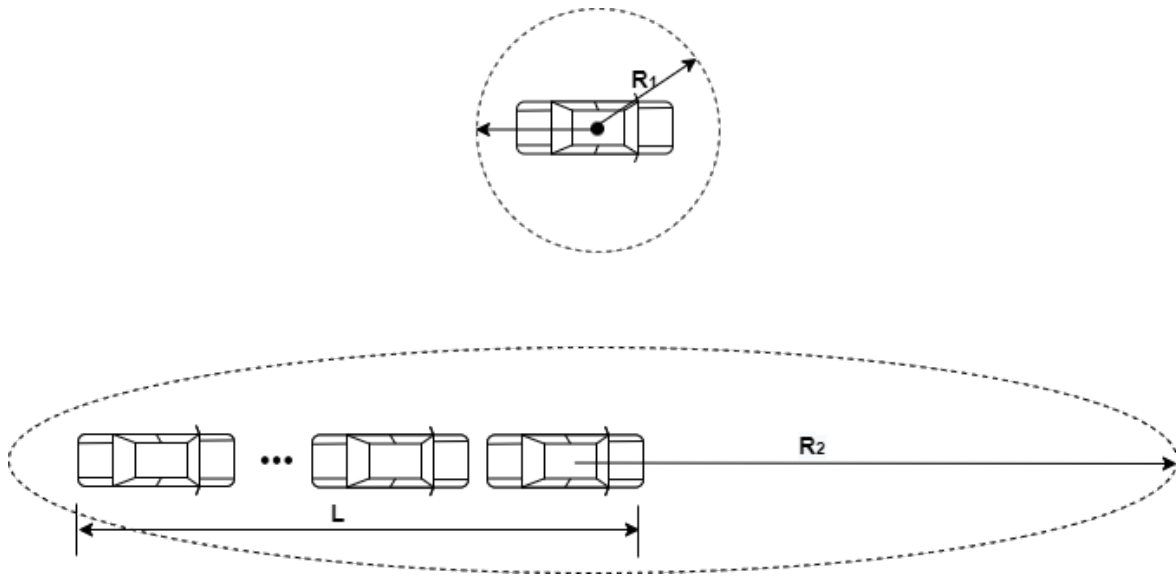

Figure 2.10. Communication range

In a leader-based platoon, the communication range of the leader vehicle should cover all members. Then the communication ranges of some platoons with the first vehicle as original point are represented as follows:

Leader following platoon:

$$[-R_2, R_2]$$

Predecessor-leader following platoon:

$$\begin{cases} [-R_2, R_2] & \text{if } R_2 > R_1 + L \\ [-(R_1 + L), R_2] & \text{if } R_2 < R_1 + L \end{cases}$$

Bidirectional platoon:

$$[-(R_1 + L), R_1]$$

Two-predecessors following platoon:

$$[-(2R_1 + L), 2R_1]$$

3. PLATOON-BASED MODEL

In Chapter 2, the features of platoon and ad hoc networks are discussed. In this chapter, a platoon-based model with two types of platoon typologies will be built. Connectivity in different situations will be analyzed.

3.1 Implementation of the platoon-based model

To make it closer to the real fact, we consider a two-way highway scenario shown in Figure 3.1. The direction of the main lane is fixed (e.g., west), and the direction of another one can be east or west. Along this two-way highway, base stations are regularly distributed, the distance between two BS is R_d . On the highway, platoons in LF topology mixed with individual vehicles are randomly distributed, the authors in [27] suggested a Poisson distribution of vehicles on the highway.

Let p denote the ratio of platoon, it can be represented by $Y/(X + Y)$, here X is the number of individual vehicles and Y is the number of platoons, each platoon in this paper will be treated as an ordinary vehicle.

$$p = \frac{Y}{X + Y} \quad (3.1)$$

The traffic density is given by ρ , which means ρ vehicles can be found in one meter. Then according to the expectation of Poisson distribution theorem, the probability of finding k vehicles at a length l area is:

$$f(k, l) = \frac{(\rho l)^k e^{-\rho l}}{k!}, k \geq 0 \quad (3.2)$$

The expectation of no vehicles ($k = 0$) in length l area is:

$$E(0) = e^{-\rho l} \quad (3.3)$$

Probability of finding at least one vehicle is:

$$P(l) = 1 - E(0) = 1 - e^{-\rho l} \quad (3.4)$$

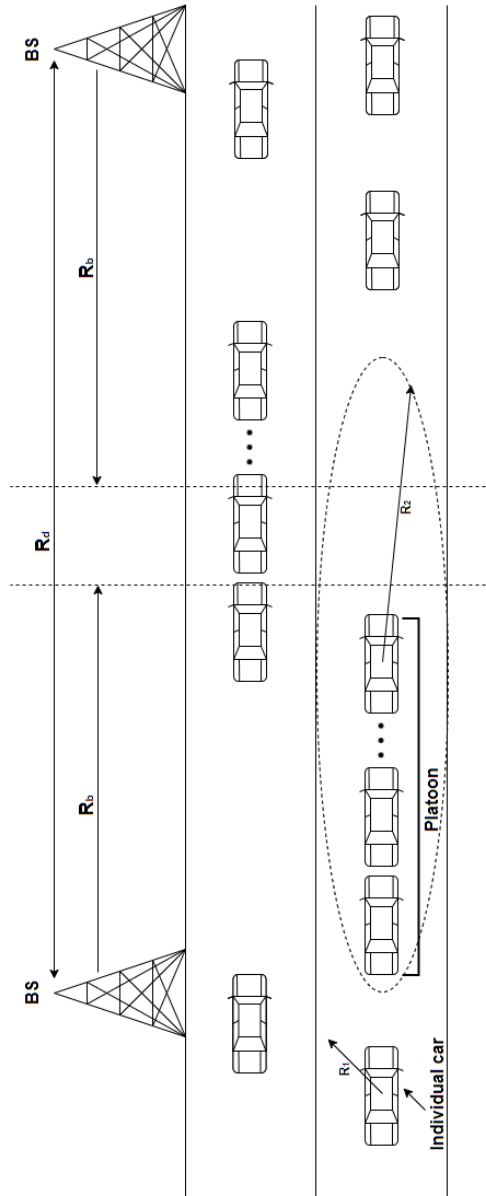

Figure 3.1. Platoon-based model

After we know the functions of connectivity probability, the communication ranges of platoon and individual vehicle should be given. We use R_1 to denote the range of individual vehicle, R_2 for platoon. Since in LF topology platoon, all vehicles are connected to the leader, as the length of platoon is ignored, R_2 represents the communication range of the leader vehicle, the communication range of the platoon covers all the vehicles.

3.2 Connectivity probability analysis in LF platoon model

Based on the model in Section 3.1, this section discusses about 5 situations in terms of the different distance between the BS. In each scenario, vehicles can connect to a BS if it is in the communication range of the BS or it can use another vehicle in that range as a relay to connect to the BS. The difference between each situation is the gap between two BS in Figure 3.2.

- $R_d \rightarrow$ Distance between two BSs
- $R_b \rightarrow$ Communication range of BS
- $d \rightarrow$ Coverage gap

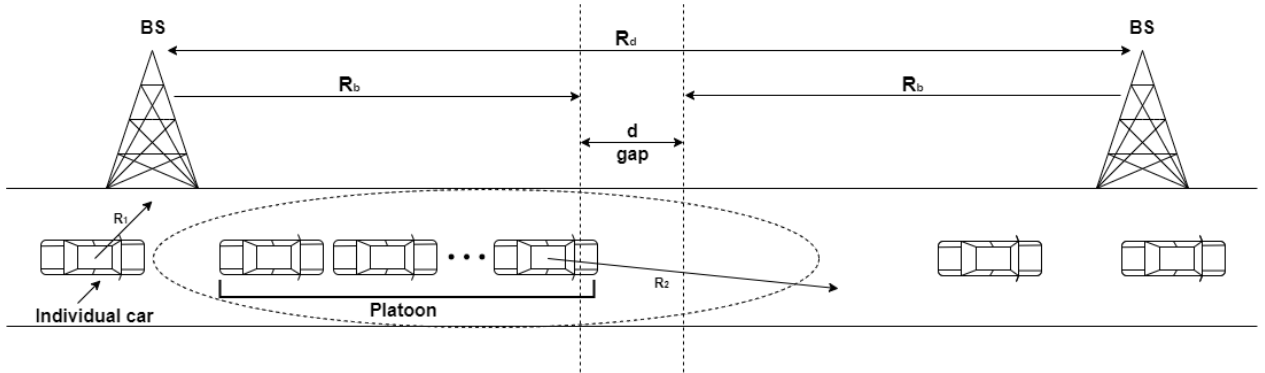

Figure 3.2. Coverage gap

According to Figure 2, the distance of gap is:

$$d = R_d - 2R_b \quad (3.5)$$

5 cases in terms of different gap distances:

Followings are 9 different probabilities discussed in each case:

- $P_t \rightarrow$ Total probability for one lane
- $p_t \rightarrow$ Total probability for two lanes
- $P_{11} \rightarrow$ Probability of individual vehicle connected with 1 BS (same lane)
- $P_{12} \rightarrow$ Probability of individual vehicle connected with 2 BSs (same lane)
- $p_{11} \rightarrow$ Probability of individual vehicle connected with 1 BS (different lane)
- $p_{12} \rightarrow$ Probability of individual vehicle connected with 2 BSs (different lane)
- $P_{21} \rightarrow$ Probability of platoon connected with 1 BS (same lane)
- $P_{22} \rightarrow$ Probability of platoon connected with 2 BSs (same lane)
- $p_{21} \rightarrow$ Probability of platoon connected with 1 BS (different lane)
- $p_{22} \rightarrow$ Probability of platoon connected with 2 BSs (different lane)

(a): $d \leq 0$

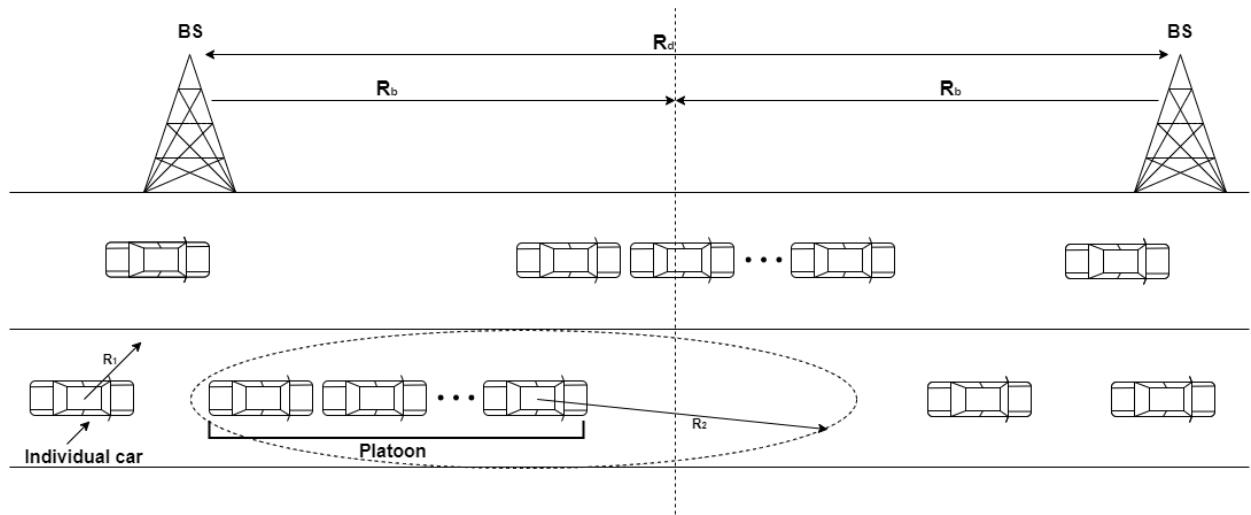

Figure 3.3. Case a: $d \leq 0$

In this case, the communication ranges of two BS can cover the entire area between them, all vehicles are able to connect to at least one BS, there is no gap on any lanes. Then the total connectivity probability should be 1:

$$P_t = 1 \quad (3.6)$$

(b): $0 < d \leq R_2 < 2R_1$

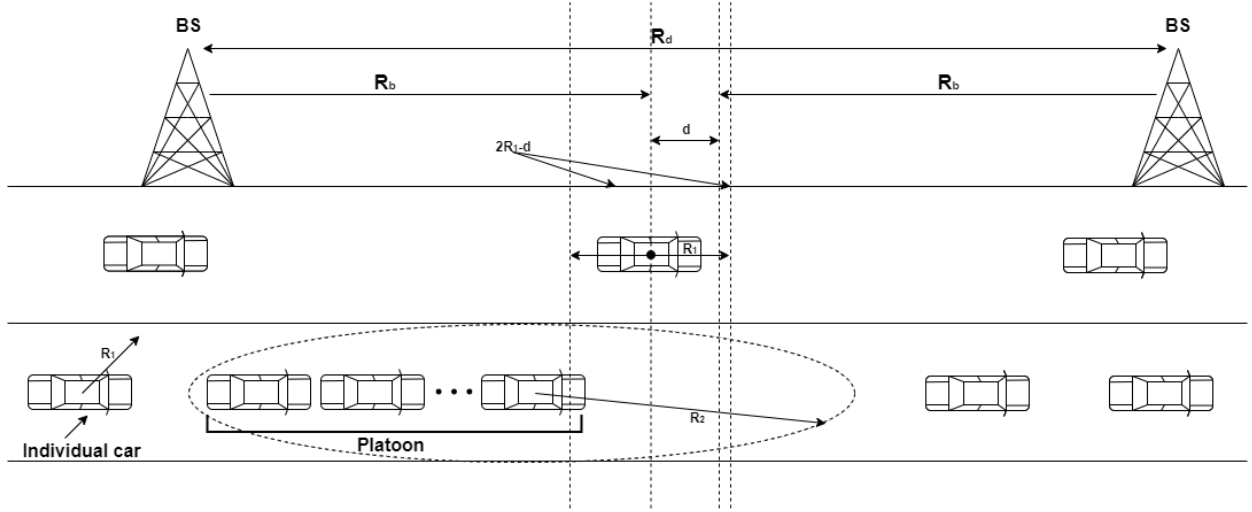

Figure 3.4. Case b: $0 < d \leq R_1$

In case b, we first consider the individual vehicle. Once an individual vehicle enters the coverage gap, it needs to find a car in its communication range. When $d < R_1$, no matter where the car is, its communication range will overlap with both BSs' communication ranges. the sum of these two areas is $2R_1 - d$, which is fixed. Hence the connectivity probability is:

$$P_{12} = \frac{d}{R_d} (1 - p) [1 - e^{-\rho(2R_1 - d)}] \quad (3.7)$$

First term in equation 6 is the probability of vehicle position, second is individual vehicle's probability, last one is the probability of finding a car in $2R_1 - d$ area according to equation 4.

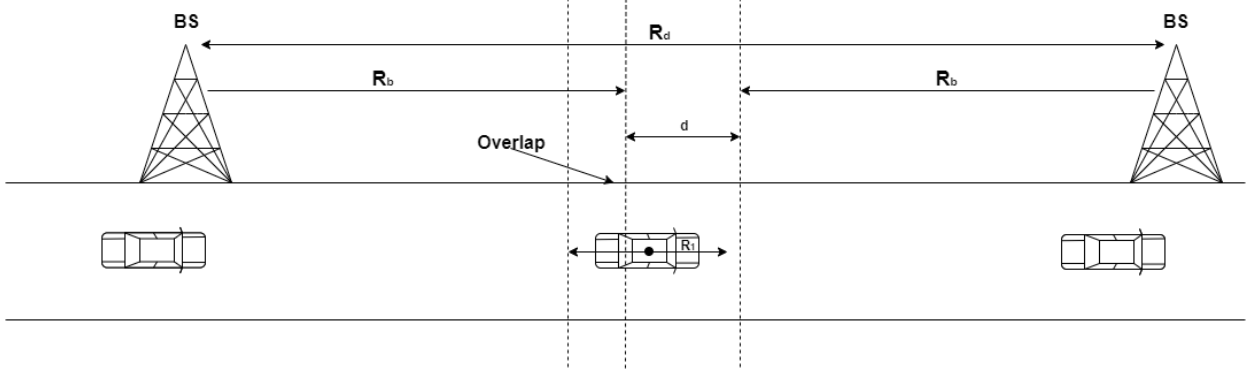

Figure 3.5. Case b: $R_1 \leq d \leq R_2 < 2R_1$

When $d \geq R_1$ (Figure 3.5), the vehicle will overlap with only one BS with a probability of $2(d - R_1)/R_d$. Since the overlapping area changes with the car position, we need to make an integral along it. Then the connectivity probability for a car to connect with one BS is:

$$P_{11} = (1 - p) \frac{2}{R_d} \int_{2R_1 - d}^{R_1} (1 - e^{-\rho l}) dl$$

$$P_{11} = \frac{2(1 - p)(d - R_1)}{R_d} + \frac{2(1 - p)[e^{-\rho R_1} - e^{-\rho(2R_1 - d)}]}{\rho R_d} \quad (3.8)$$

If a platoon is in the coverage gap, because $d < R_2$, the platoon always has the probability to connect with 2 BSs. We only need to consider one situation, which is same as first situation of individual vehicle. So the connectivity probability for a platoon is:

$$P_{22} = p \frac{d}{R_d} [1 - e^{-\rho(2R_2 - d)}] \quad (3.9)$$

By adding equations 3.7, 3.8, 3.9 and the probability of not in coverage gap, the total connectivity probability for one lane is:

$$P_t = \frac{2R_b}{R_d} + P_{12} + P_{11} + P_{22}$$

$$\begin{aligned}
P_t = & \frac{2R_b}{R_d} + \frac{d}{R_d}(1-p)[1 - e^{-\rho(2R_1-d)}] \\
& + \frac{2(1-p)(d-R_1)}{R_d} + \frac{2(1-p)[e^{-\rho R_1} - e^{-\rho(2R_1-d)}]}{\rho R_d} \\
& + \frac{d}{R_d}(1-p)[1 - e^{-\rho(2R_2-d)}] \quad (3.10)
\end{aligned}$$

Moreover, the vehicle also can relay on other cars in another lane if no cars can be found in its lane. Supposing the distance between two lanes is h in Figure 3.6.

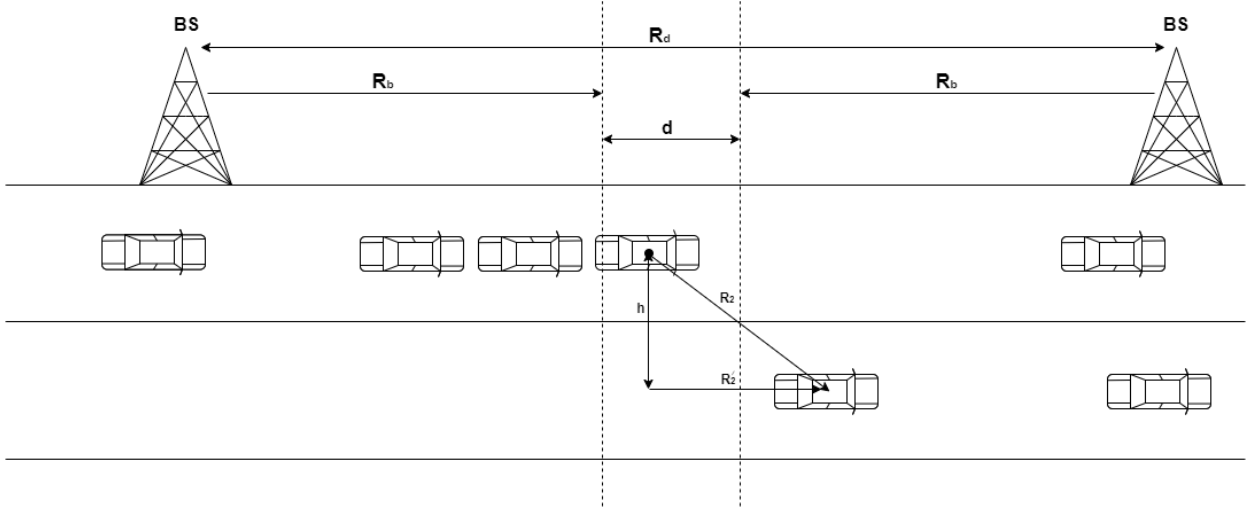

Figure 3.6. Case b: 2 lanes scenario

As a result, the equivalent range $R'_{2(1)}$ is represented by:

$$R'_{2(1)} = \sqrt{R_{2(1)}^2 - h^2} \quad (3.11)$$

By replacing $R_{1(2)}$ with equivalent range $R'_{1(2)}$ in equations 3.7, 3.8, 3.9, we have 3 new probability formulas, the last term is the probability of unable to find a car in original lane.

$$p_{12} = \frac{d}{R_d}(1-p)[1 - e^{-\rho(2R'_1-d)}]e^{-\rho(2R_1-d)} \quad (3.12)$$

$$p_{11} = (1-p)\frac{2}{R_d} \int_{R'_1+R_1-d}^{R'_1} (1 - e^{-\rho l}) \cdot (-e^{-\rho l}) dl$$

$$p_{11} = \frac{2(1-p)[e^{-\rho R_1} - e^{-\rho(2R_1-d)}]}{\rho R_d} \cdot [(d - R_1) + \frac{[e^{-\rho(R_1+R'_1-d)} - e^{-\rho R'_1}]}{\rho}] \quad (3.13)$$

$$p_{22} = p \frac{d}{R_d} [1 - e^{-\rho(2R'_2-d)}] e^{-\rho(2R_2-d)} \quad (3.14)$$

Combine the results in one lane and two lanes, we have the total probability in 2 lanes scenario:

$$p_t = \frac{2R_b}{R_d} + P_{12} + P_{11} + P_{22} + p_{12} + p_{11} + p_{22} \quad (3.15)$$

Which is:

$$\begin{aligned} P_t = & \frac{d}{R_d} (1-p)[1 - e^{-\rho(2R_1-d)}] + \frac{2(1-p)(d - R_1)}{R_d} + \frac{2(1-p)[e^{-\rho R_1} - e^{-\rho(2R_1-d)}]}{\rho R_d} \\ & + \frac{d}{R_d} (1-p)[1 - e^{-\rho(2R_2-d)}] + \frac{d}{R_d} (1-p)[1 - e^{-\rho(2R'_1-d)}] e^{-\rho(2R_1-d)} \\ & + \frac{2(1-p)[e^{-\rho R_1} - e^{-\rho(2R_1-d)}]}{\rho R_d} \cdot [(d - R_1) + \frac{[e^{-\rho(R_1+R'_1-d)} - e^{-\rho R'_1}]}{\rho}] \\ & + \frac{d}{R_d} (1-p)[1 - e^{-\rho(2R'_2-d)}] e^{-\rho(2R_2-d)} + \frac{2R_b}{R_d} \end{aligned} \quad (3.16)$$

(c) $R_2 < d \leq 2R_1$

In this case, if the car located in coverage gap is an individual vehicle, since the maximum gap distance is no greater than $2R_1$, no matter where the car is, it will have a probability to connect to a BS. Similarly for individual vehicle, there are 2 situations, which are same as case b, thus the connectivity probability of individual vehicle is the sum of equations 3.7, 3.8, 3.12, 3.13.

If the vehicle located in the gap is a platoon, we also need to consider 2 situations. The platoon leader will be able to connect to only one BS with the probability of $2(d - R_2)/R_d$, under this situation, the probability is a function of integral, it can be represented by:

$$P_{21} = p \frac{2}{R_d} \int_{2R_2-d}^{R_2} (1 - e^{-\rho l}) dl$$

$$P_{21} = \frac{2p(d - R_2)}{R_d} + \frac{2p[e^{-\rho R_2} - e^{-\rho(2R_2-d)}]}{\rho R_d} \quad (3.17)$$

On the second lane:

$$p_{21} = p \frac{2}{R_d} \int_{R'_2+R_1-d}^{R'_2} (1 - e^{-\rho l}) dl \cdot \left[\int_{2R_2-d}^{R_2} (-e^{-\rho l}) dl \right]$$

$$p_{21} = \frac{2p[e^{-\rho R_2} - e^{-\rho(2R_2-d)}]}{\rho R_d} \cdot \left[(d - R_2) + \frac{[e^{-\rho(R_2+R'_2-d)} - e^{-\rho R'_2}]}{\rho} \right] \quad (3.18)$$

Another situation is same as equation 8 in case b. Then, overall connectivity probability for two lanes can be given by:

$$p_t = \frac{2R_b}{R_d} + P_{12} + P_{21} + P_{11} + P_{22} + p_{12} + p_{21} + p_{11} + p_{22}$$

Which is:

$$P_t = \frac{d}{R_d} (1-p)[1 - e^{-\rho(2R_1-d)}] + \frac{2p(d - R_2)}{R_d} + \frac{2p[e^{-\rho R_2} - e^{-\rho(2R_2-d)}]}{\rho R_d}$$

$$+ \frac{2(1-p)(d - R_1)}{R_d} + \frac{2(1-p)[e^{-\rho R_1} - e^{-\rho(2R_1-d)}]}{\rho R_d} + \frac{d}{R_d} (1-p)[1 - e^{-\rho(2R_2-d)}]$$

$$+ \frac{d}{R_d} (1-p)[1 - e^{-\rho(2R'_1-d)}]e^{-\rho(2R_1-d)} + \frac{d}{R_d} (1-p)[1 - e^{-\rho(2R'_2-d)}]e^{-\rho(2R_2-d)}$$

$$+ \frac{2(1-p)[e^{-\rho R_1} - e^{-\rho(2R_1-d)}]}{\rho R_d} \cdot \left[(d - R_1) + \frac{[e^{-\rho(R_1+R'_1-d)} - e^{-\rho R'_1}]}{\rho} \right]$$

$$+ \frac{2p[e^{-\rho R_2} - e^{-\rho(2R_2-d)}]}{\rho R_d} \cdot \left[(d - R_2) + \frac{[e^{-\rho(R_2+R'_2-d)} - e^{-\rho R'_2}]}{\rho} \right] + \frac{2R_b}{R_d} \quad (3.19)$$

(d) $2R_1 < d \leq 2R_2$

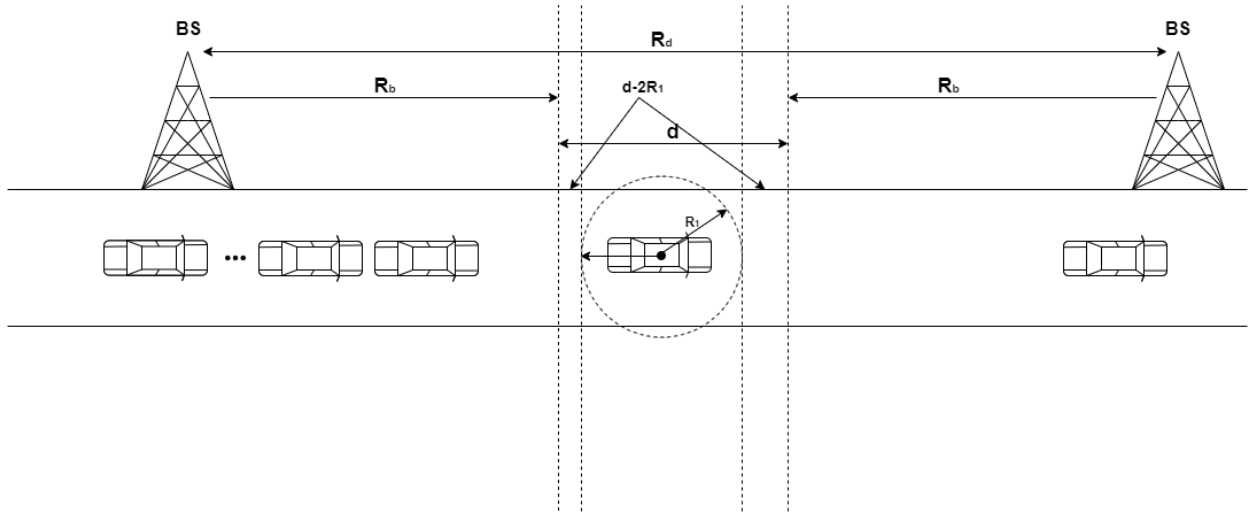

Figure 3.7. Case d: Blind area

In case d, the individual vehicle begins to have a blind area. For example, in Figure 3.7, this individual vehicle's communication range does not have an overlapping area with BS. In other words, it cannot rely on only one neighbor vehicle to connect to the BS, which means 0 connectivity probability. The probability of this situation is $(d - 2R_1)/R_d$. Besides, the individual vehicle is unable to connect to either BS via a relay due to the same reason.

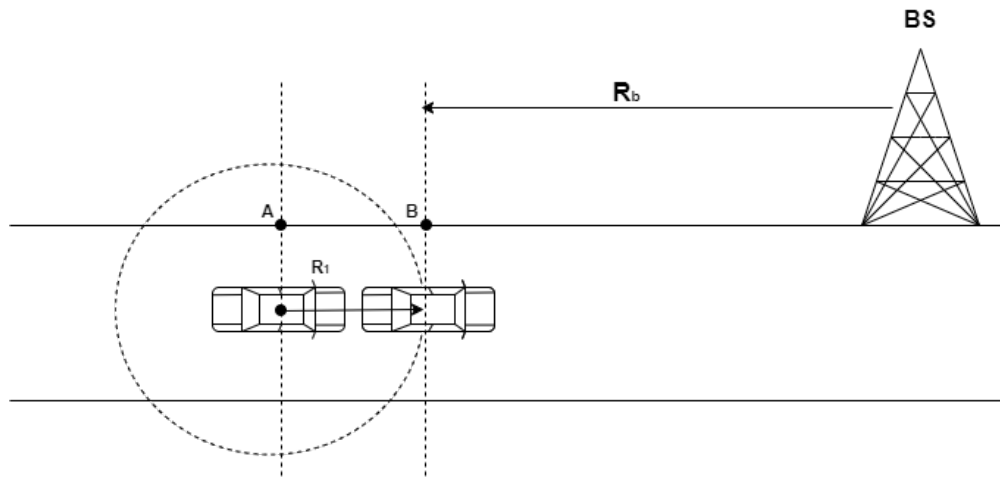

Figure 3.8. Case d: Connected via one hop

To make sure there exist overlapping area between vehicle and BS, the vehicle must be at right side of point A in Figure 3.8. When this vehicle is moving from A to B, the overlapping area increases, as well as the connectivity probability. Consider two directions, the overall connectivity probability of individual vehicle on one lane can be given by:

$$P_{11} = (1-p) \frac{2}{R_d} \int_0^{R_1} (1 - e^{-\rho l}) dl$$

$$P_{11} = \frac{2(1-p)R_1}{R_d} + \frac{2(1-p)[e^{-\rho R_1} - 1]}{\rho R_d} \quad (3.20)$$

In two lane scenario, by replacing R_1 with R'_1 , the new equation will be:

$$p_{11} = (1-p) \frac{2}{R_d} \int_0^{R'_1} (1 - e^{-\rho l})(-e^{-\rho l}) dl$$

$$p_{11} = \frac{(1-p)[e^{-2\rho R'_1} - 2e^{-\rho R'_1}]}{2\rho R_d} \quad (3.21)$$

If the vehicle located in gap area is a platoon, we can still use the results in case c, because the change of gap distance from case c to d does not affect platoon situations. The overall connectivity probability for two lanes can be given by:

$$p_t = \frac{2R_b}{R_d} + P_{21} + P_{11} + P_{22} + p_{21} + p_{11} + p_{22}$$

Which is:

$$P_t = \frac{2R_b}{R_d} + \frac{2p(d - R_2)}{R_d} + \frac{2p[e^{-\rho R_2} - e^{-\rho(2R_2-d)}]}{\rho R_d}$$

$$+ \frac{2(1-p)R_1}{R_d} + \frac{2(1-p)[e^{-\rho R_1} - 1]}{\rho R_d} + \frac{d}{R_d} (1-p)[1 - e^{-\rho(2R_2-d)}]$$

$$+ \frac{2p[e^{-\rho R_2} - e^{-\rho(2R_2-d)}]}{\rho R_d} \cdot \left[(d - R_2) + \frac{[e^{-\rho(R_2+R'_2-d)} - e^{-\rho R'_2}]}{\rho} \right]$$

$$+ \frac{(1-p)[e^{-2\rho R'_1} - 2e^{-\rho R'_1}]}{2\rho R_d} + \frac{d}{R_d} (1-p)[1 - e^{-\rho(2R'_2-d)}] e^{-\rho(2R_2-d)} \quad (3.22)$$

(e) $d > 2R_2$

In this case, both individual vehicle and platoon has blind area, the connectivity probability for individual vehicle is same as case d. For platoon, it will be represented by:

one lane:

$$P_{21} = \frac{2pR_2}{R_d} + \frac{2p[e^{-\rho R_2} - 1]}{\rho R_d} \quad (3.23)$$

two lanes:

$$p_{21} = \frac{p[e^{-2\rho R'_2} - 2e^{-\rho R'_2}]}{2\rho R_d} \quad (3.24)$$

The overall connectivity probability for two lanes can be given by:

$$p_t = \frac{2R_b}{R_d} + P_{21} + P_{11} + p_{21} + p_{11}$$

$$P_t = \frac{2(1-p)R_1}{R_d} + \frac{2(1-p)[e^{-\rho R_1} - 1]}{\rho R_d} + \frac{p[e^{-2\rho R'_2} - 2e^{-\rho R'_2}]}{2\rho R_d} + \frac{(1-p)[e^{-2\rho R'_1} - 2e^{-\rho R'_1}]}{2\rho R_d} + \frac{p[e^{-2\rho R'_2} - 2e^{-\rho R'_2}]}{2\rho R_d} + \frac{2R_b}{R_d} \quad (3.25)$$

3.3 BD topology platoon model

This section is the same modal for a BD topology platoon, which is a no-leader based platoon. As it does not have a leader, a new communication range should be given. Since every vehicles in this platoon is equivalent, the communication ranges of them must be the same. To make the results more accurate, we assume that the communication ranges of vehicles in platoon is also R_1 . In addition, the length of platoon needs to be considered. Let L denote the length of it and the ratio of platoon be 1. Position of the first vehicle in platoon represent the position of the platoon. Other parameters are same as what in Section 3.3.

Because connection between platoon members are enabled, the platoon is said to be connected if any vehicle in it can connect to the BS. Similarly, 4 different cases in terms of coverage gap are discussed in this section.

6 cases in terms of different gap distances:

(a) $d < L$

In this case, no matter where the platoon is, it has an overlapping area with at least one BS. Thus overall probability is 1.

(b) $L < d \leq 2L$

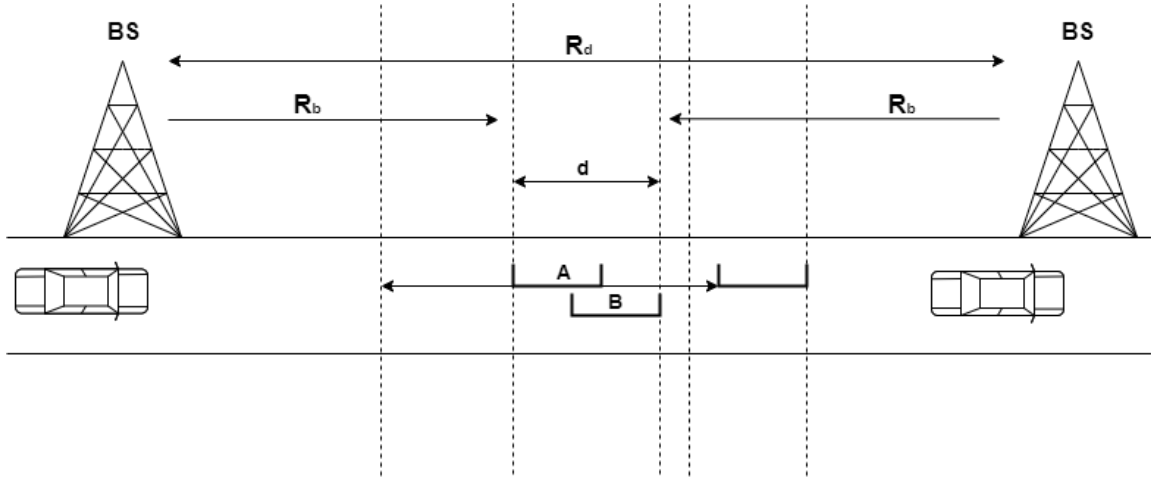

Figure 3.9. Case b: $L < d \leq 2L$

In case b, platoon are always able to connect to two BSs via one hop from location A to B in Figure 3.9, only one situation exists. The communication range is $2R_1 + L$, After removing the length of platoon, the probability of connecting to either BS via one hop is:

$$P_{22} = \frac{(d - L)}{R_d} [1 - e^{-\rho(2R_1)}] \quad (3.26)$$

Overall connectivity probability of platoon in two ways scenario is:

$$P_t = \frac{2R_d + L}{R_d} + P_{22}$$

Which is:

$$P_t = \frac{2R_d + L}{R_d} + \frac{(d - L)}{R_d} [1 - e^{-\rho(2R_1)}] \quad (3.27)$$

(c) $2L < d \leq 2L + R_1$

In this case, platoons still have chance to connect to both BSs via one hop, however, the overlapping area is changed.

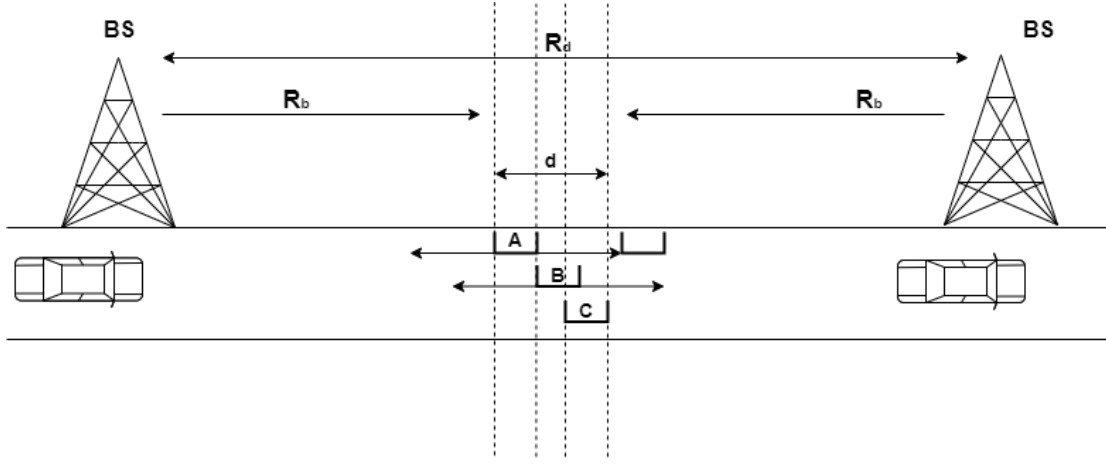

Figure 3.10. Case c: $2L < d \leq 2L + R_1$

In Figure 3.10, from position A to B, the length of overlapping area is increasing, which is:

$$2R_1 + 2L - d \rightarrow 2R_1 + 3L - d$$

Connectivity probability in AB interval is given by:

$$\frac{1}{R_d} \int_{2R_1+2L-d}^{2R_1+3L-d} (1 - e^{-\rho l}) dl$$

From position B to C, the length of overlapping area is fixed, which is:

$$2R_1 + 3L - d$$

Connectivity probability in BC interval is given by:

$$\frac{d - 2L}{R_d} (1 - e^{-\rho(2R_1+3L-d)})$$

P_{22} is the sum of these 2 probabilities:

$$P_{22} = \frac{1}{R_d} \int_{2R_1+2L-d}^{2R_1+3L-d} (1 - e^{-\rho l}) dl + \frac{d-2L}{R_d} (1 - e^{-\rho(2R_1+3L-d)}) \quad (3.28)$$

Finally, Overall connectivity probability of platoon in this scenario is:

$$P_t = \frac{2R_d + L}{R_d} + P_{22}$$

$$P_t = \frac{2R_d + L}{R_d} + \frac{1}{R_d} \int_{2R_1+2L-d}^{2R_1+3L-d} (1 - e^{-\rho l}) dl + \frac{d-2L}{R_d} (1 - e^{-\rho(2R_1+3L-d)}) \quad (3.29)$$

(d) $2L + R_1 < d \leq 3L + R_1$

Figure 3.11 shows case d. In this case, platoons begin to have chances to connect to only one BS.

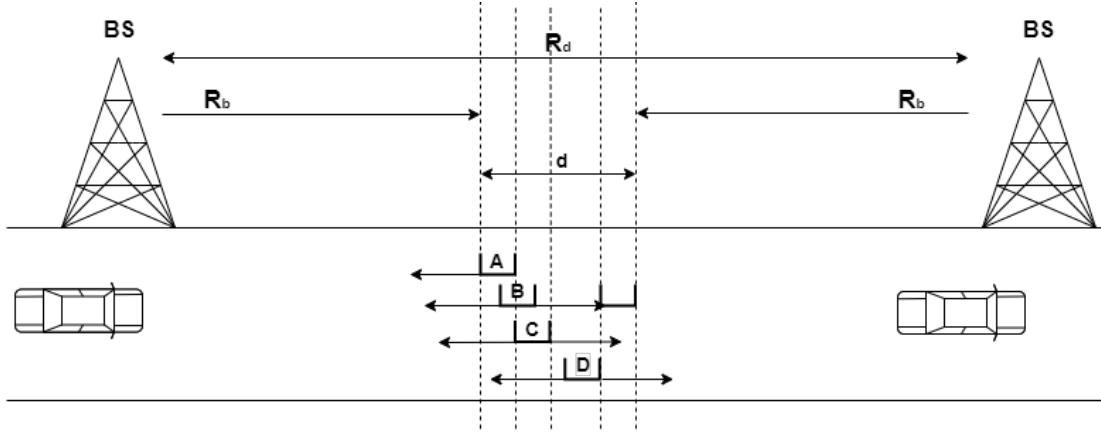

Figure 3.11. Case d: $2L + R_1 < d \leq 3L + R_1$

From position A to B, platoon can only connect to the left BS via a hop. The length between A and B is $d - 2L - R_1$. Overlapping area is fixed, so the connectivity probability is:

$$\frac{d - 2L - R_1}{R_d} [1 - e^{-\rho R_1}]$$

In BC area, overlapping area increases because platoon is able to connect to the right BS. Changes of overlapping area is:

$$R_1 \rightarrow 2R_1 + 3L - d$$

Then connectivity probability is:

$$\frac{1}{R_d} \int_{R_1}^{2R_1+3L-d} (1 - e^{-\rho l}) dl$$

If the platoon is located in CD area, connectivity is same as it in BC area of case c, thus the connectivity probability is given by:

$$\frac{d - 3L}{R_d} (1 - e^{-\rho(2R_1+3L-d)})$$

Due to the symmetry, platoons in last district have same probability with the first situation. In summary, two times of probability in situation 1 is P_{21} , the sum of other situation 2 and 3 is P_{22} . Overall connectivity probability is :

$$P_t = \frac{2R_d + L}{R_d} + P_{21} + P_{22}$$

$$\begin{aligned} P_t = & \frac{2R_b + L}{R_d} + \frac{d - L - R_1}{R_d} [1 - e^{-\rho R_1}] \\ & + \frac{1}{R_d} \int_{R_1}^{2R_1+3L-d} (1 - e^{-\rho l}) dl \\ & + \frac{d - 3L}{R_d} (1 - e^{-\rho(2R_1+3L-d)}) \quad (3.30) \end{aligned}$$

(e) $3L + R_1 < d \leq 2R_1 + 3L$

Figure 3.12 shows case e, probabilities in AB and CD are same as the corresponding probabilities in case d. New situations are BC and DE.

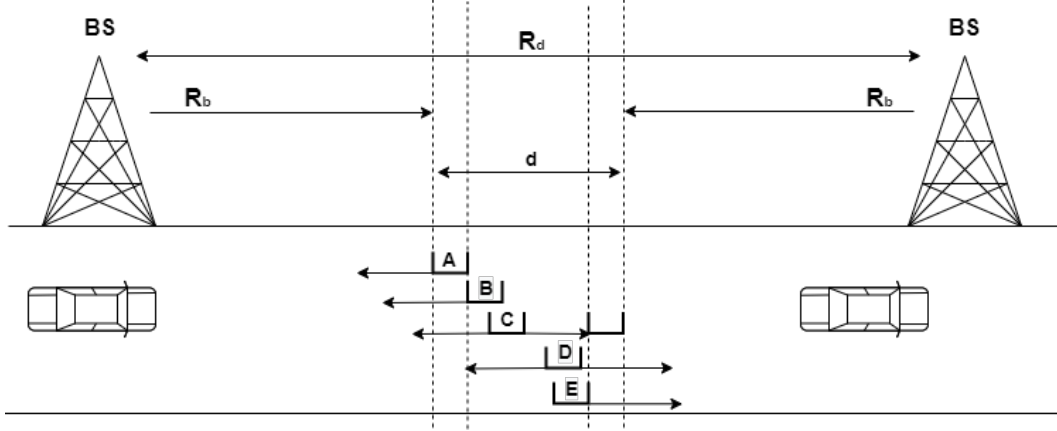

Figure 3.12. Case e: $3L + R_1 < d \leq 2R_1 + 3L$

From position B to C, overlapping area decreases from R_1 to $(2R_1 + 3L - d)$, then connectivity probability is:

$$\frac{1}{R_d} \int_{2R_1+3L-d}^{R_1} (1 - e^{-\rho l}) dl$$

The distance between D and E is $d - R_1 - 3L$, then connectivity probability should be same as the probability in BC. So, the overall connectivity probability is:

$$P_t = \frac{2R_d + L}{R_d} + P_{21} + P_{22}$$

$$P_t = \frac{2R_b + L}{R_d} + \frac{2L}{R_d} [1 - e^{-\rho R_1}] + \frac{2}{R_d} \int_{2R_1+3L-d}^{R_1} (1 - e^{-\rho l}) dl + \frac{2R_1 + 3L - d}{R_d} (1 - e^{-\rho(2R_1+3L-d)}) \quad (3.31)$$

(f) $d > 2R_1 + 3L$

Blind area shown in Figure 3.13 appears in case f, which means the overall connectivity probability will not reach to 1. Probability in AB is same as it in case e.

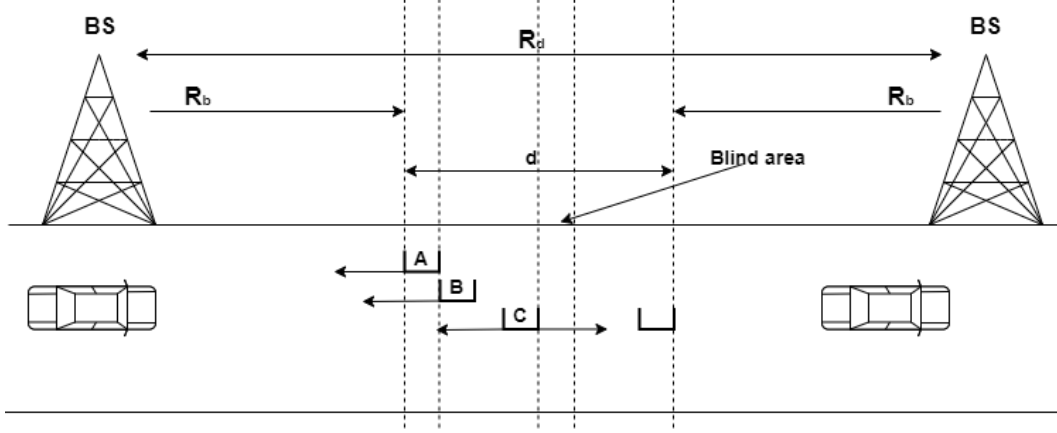

Figure 3.13. Case f: $d > 2R_1 + 3L$

Probability in BC is:

$$\frac{1}{R_d} \int_0^{R_1} [1 - e^{-\rho l}] dl$$

In terms of symmetry, overall probability is given by:

$$P_t = \frac{2R_d + L}{R_d} + P_{21}$$

$$P_t = \frac{2R_d + L}{R_d} + \frac{2L}{R_d} [1 - e^{-\rho R_1}] + \frac{2}{R_d} \int_0^{R_1} [1 - e^{-\rho l}] dl \quad (3.32)$$

3.4 Two ways BD platoon based model

Figure 3.14 shows an example of two ways BD platoon based model ($2L < d < L + R_1$), it has 2 advantages compared with LF platoon based model.

Firstly, the length of platoon decreases the coverage gap. Consider this model, the equivalent communication range in the second lane is same as the corresponding one in LF platoon based model, however, we also need to consider platoons located in coverage gap at the second lane. As we assume that the first vehicle indicates the position of the platoon, platoons in the yellow districts shown in Figure 3.14 are all connected directly to the BS, and

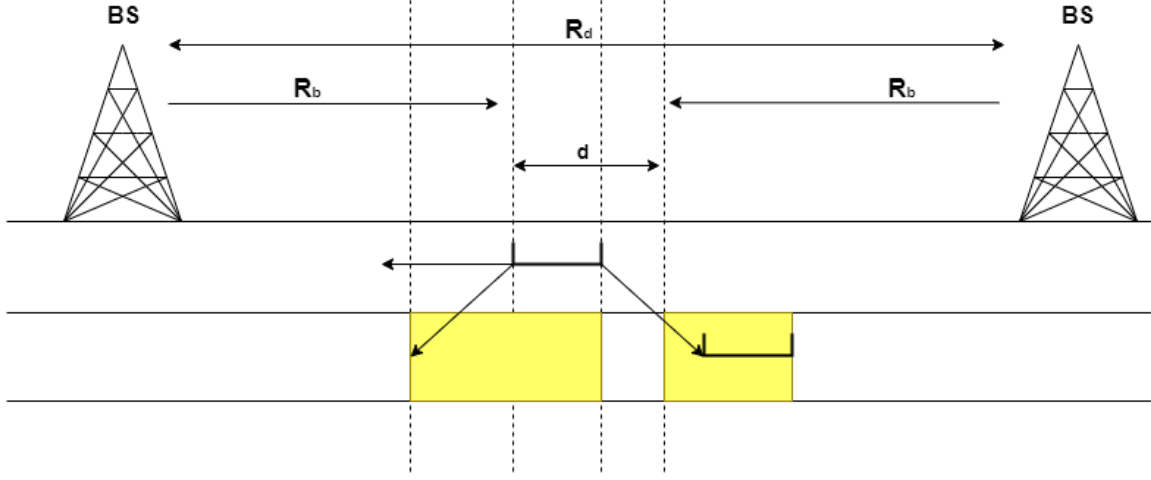

Figure 3.14. Case c: Two lanes scenario

they are also in the communication range of considered platoon, which means any platoon of them can be a relay.

The second point is the length of platoon increases the communication range. Also in Figure 3.14, in a LF platoon based model, overlapping area should be $R'_1 + R_1 - dd$, L meters shorter than it in this model.

Both two points will improve the probability of relaying on another platoon at other lanes.

The length of the yellow area is:

$$3L + 2R'_1 - d$$

Probability of finding at least one platoon in shadow area is:

$$1 - e^{-\rho(3L+2R'_1-d)}$$

Connectivity probability of relaying on platoons in another lane is:

$$p_{22} = \frac{(d - L)}{R_d} e^{-\rho(2R_1)} [1 - e^{-\rho(3L+2R'_1-d)}] \quad (3.33)$$

3.5 Summary

After we discussed about 5 cases of LF platoon based model and 6 cases of BD platoon based model, we know that the distance of coverage gap has a great influence on the connectivity probability. In the first model, if the distance is short enough, e.g., d is shorter than $2R_1$, then the vehicles have chances to connect to BS in terms of the traffic density. On the other hand, if d is greater than $2R_2$, the connectivity probability will never be 1, which is similar in the second model. In addition, comparisons are given to show the advantages in either models. What's more, other parameters like the number of individual vehicles and platoons, traffic density, number of lanes will also be tested and compared in Chapter 4.

4. SIMULATION AND RESULTS

In last chapter, we built a VANETs model, analyzed 5 LF-platoon and 6 BD-platoon cases in terms of the coverage gap distance between two BSs. In Chapter 4, simulation of those cases was carried out on MATLAB. Simulations for 5 original cases are shown in Section 4.1, it also includes the cooperation of different traffic density in certain cases. Section 4.2 and 4.3 studies the effect of platoon's ratio and number of lanes separately in this VANETs model. Section 4.4 area the results of 6 BD-platoon cases compared to the original cases.

4.1 Results of 5 original cases

Table 4.1 shows all parameters in the simulation.

Table 4.1. All parameter values for 5 original cases

Parameter	Value
X	50
Y	50
R_d	4400, 4500, 4800, 5500
R_b	2000
h	5
ρ	0→0.1
Number of lane	1, 2

As we know that when d is smaller than 0, the connectivity probability is always 1, then only 4 cases need simulations. In Figure 4.1, we have 4 curves of overall connectivity probability for 2 lanes highway, it can be observed that the connectivity probability becomes larger as the traffic density increases for all cases. The start and end points decrease as the gap distance is increasing. The blue and red ones represent case b and c in Chapter 3, the limitation of these two curves is 1, whereas the other two curves cannot reach limitation of 1. Clearly, the missing probability for yellow and purple curves is the ratio of blind area in case d and e.

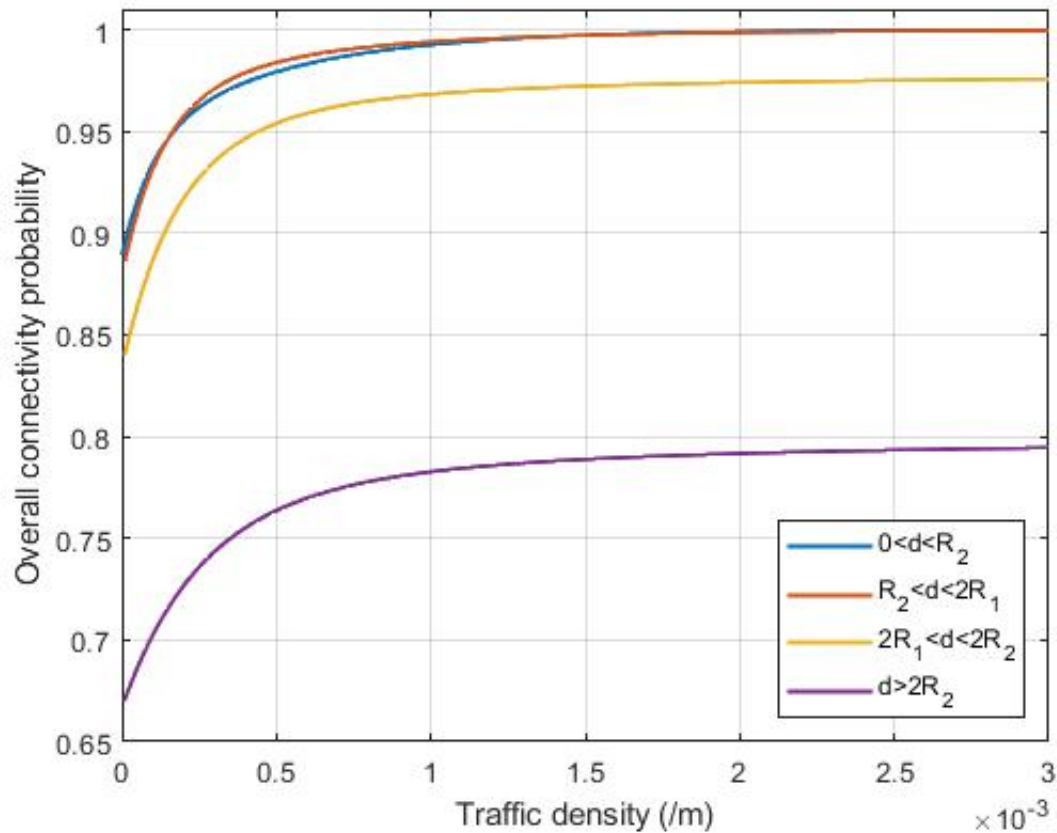

Figure 4.1. Overall connectivity probability

Specific connectivity probabilities of individual vehicle and platoon are shown in Figure 4.2 and 4.3, the end points of them are not monotone functions like overall probability. The maximum values of them become larger as the coverage gap distance increases until blind area appears. The connectivity probability of platoon reaches peak value faster than individual vehicle's because it has a bigger communication range.

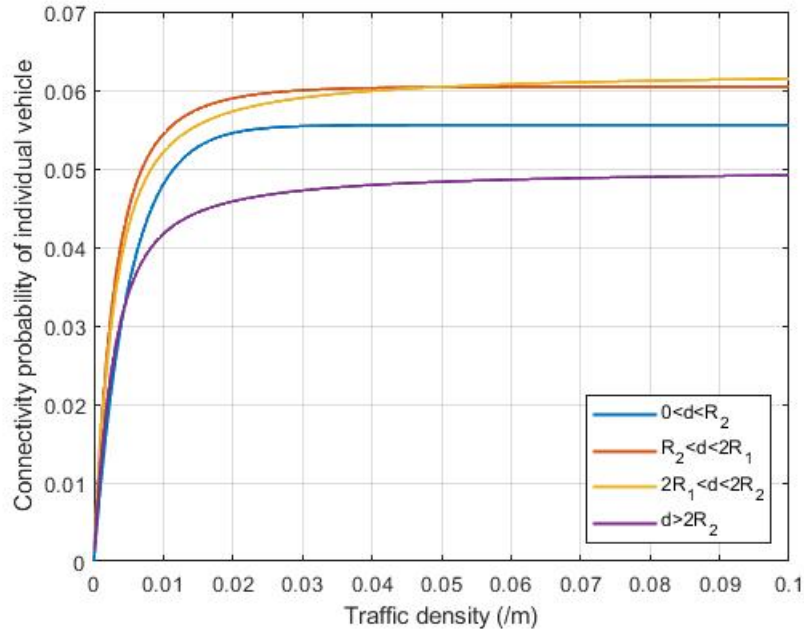

Figure 4.2. Connectivity probability of individual vehicles in coverage gap

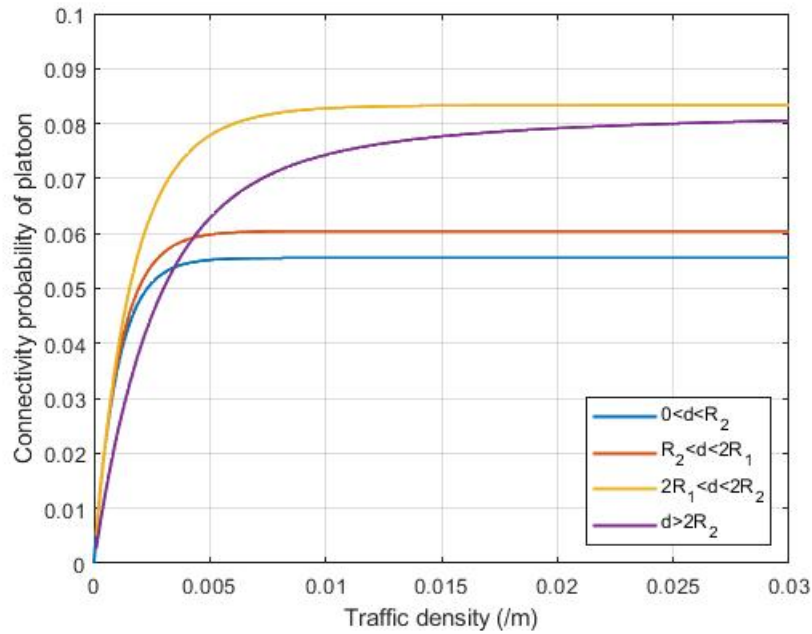

Figure 4.3. Connectivity probability of platoons in coverage gap

4.2 Connectivity probability with different ratio of platoon

In this section, we make sure that the gap distance are not changed, let ratio of platoon become a variable, Table 4.2 shows all parameters in the simulation.

Table 4.2. All parameter values for different ratio of platoon cases

Parameter	Value
X	0→100
Y	100→0
R_d	4800
R_b	2000
h	5
ρ	0.001, 0.01, 0.05
Number of lane	2

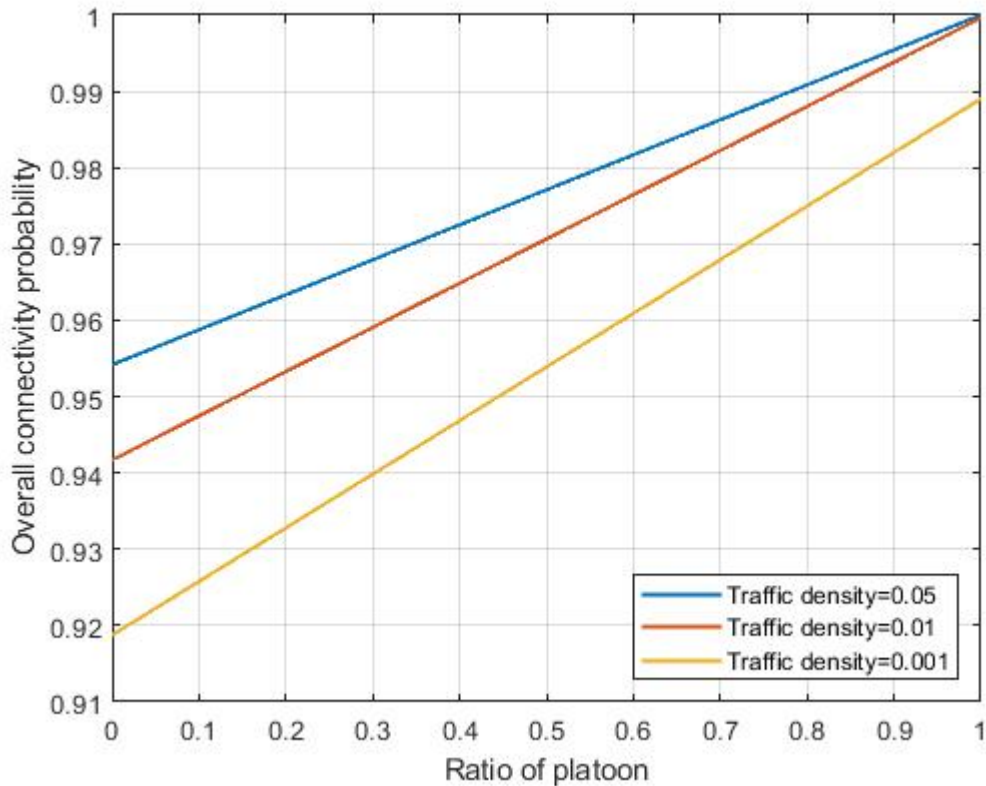

Figure 4.4. Overall connectivity probability with different ratio of platoon

Figure 4.4 shows the connectivity probability of the network in terms of the ratio of platoon. The connectivity probability functions are linear monotone increasing. That means whenever increase the ratio of platoon in this mixed vehicle type of environment will effectively increase the connectivity probability, no platoon saturation exists. What is more, the lower the traffic density the higher the slope of the lane. This reflects that it is more appropriate to increase the ratio of platoon at a lower traffic density situation.

4.3 Connectivity probability with different coverage gap

Section 4.3 is an extension of Section 4.1, 4 coverage gaps were given in 4.1, this section shows the specific relationship between coverage gap distance and overall connectivity probability, Table 4.3 shows all parameters in the simulation.

Table 4.3. All parameter values for different ratio of platoon cases

Parameter	Value
X	50
Y	50
R_d	4800→10000
R_b	2000
h	5
ρ	0.001, 0.005, 0.05
Number of lane	2

In this simulation, connectivity probability decreases as the length of coverage gap distance increase. The leading factor in this probability function is the ratio of area which is in transmission range of BS. If we need > 0.9 connectivity probability with a 0.005 numbers of vehicle per meter, the BS interval should be smaller than 5000m.

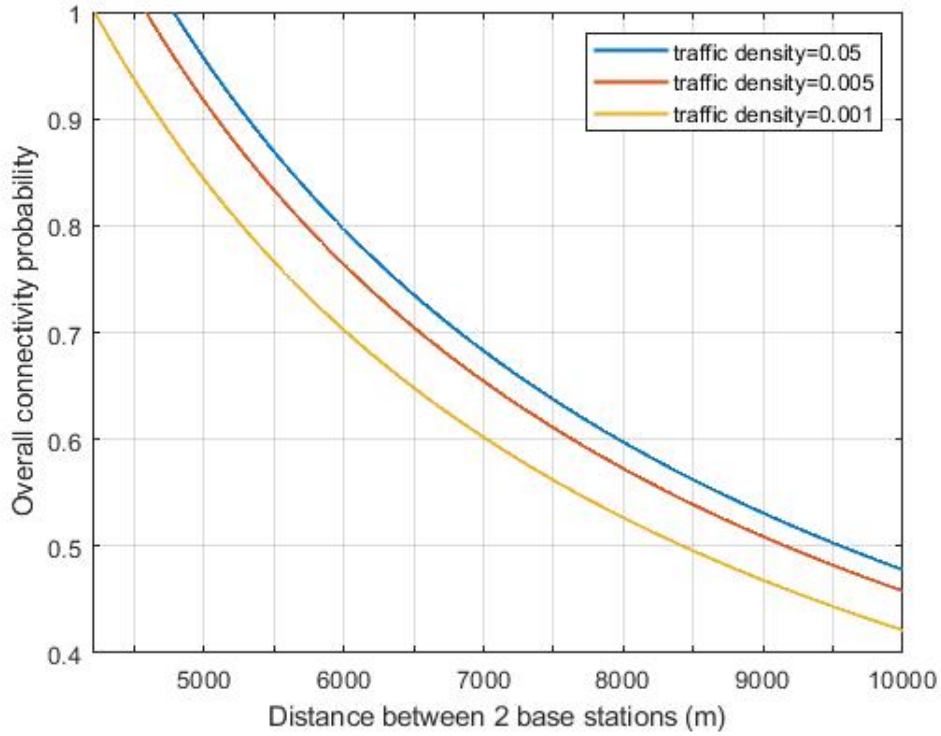

Figure 4.5. Overall connectivity probability with different intervals of BSs

4.4 Connectivity probability with different lanes

The number of lanes is also an important factor in probability function. Commonly, there will be 2-4 lanes on one direction of a highway. Section 4.4 shows the results in terms of different number of lanes with a fixed BS interval and 3 different traffic density. All parameters are given in Table 4.4.

Table 4.4. All parameter values for different intervals of BSs cases

Parameter	Value
X	50
Y	50
R_d	4800
R_b	2000
h	5
ρ	0.001, 0.005, 0.05
Number of lane	1, 2, 3, 4

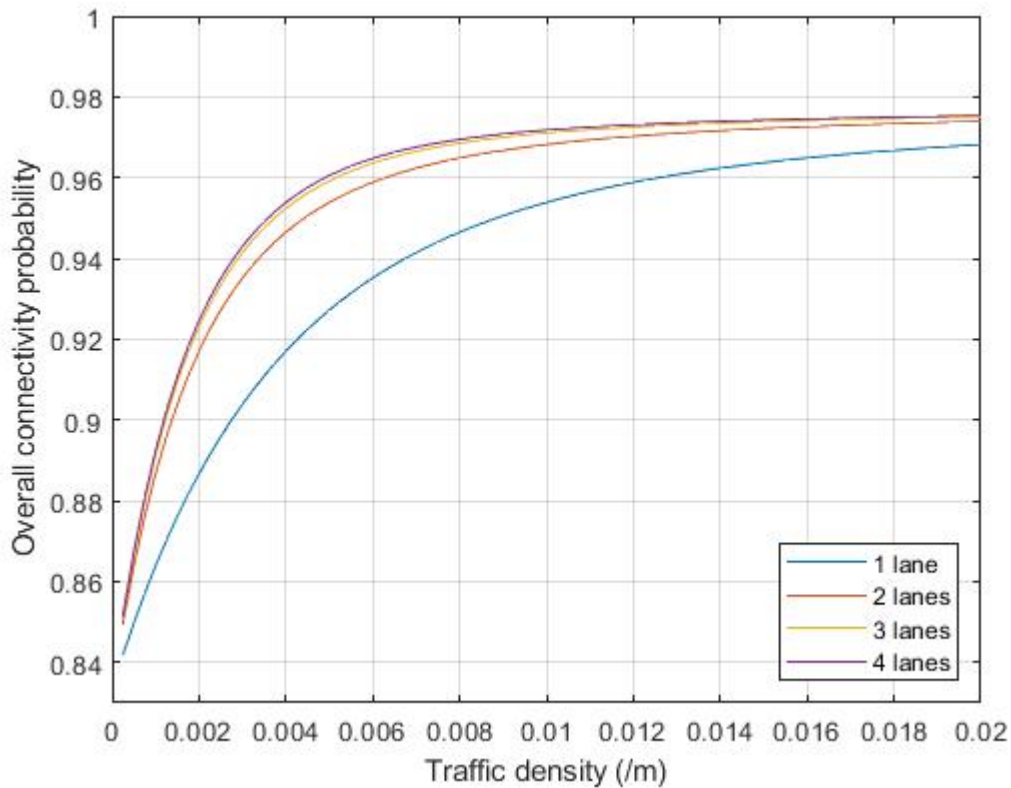

Figure 4.6. Overall connectivity probability with different number of lanes

In this case, it can be observed from Figure 4.6 that the number of considered lanes increasing results in higher connectivity probability, but the growth range is decreasing. That is because when a vehicle needs to find a relay on other lanes, it cannot relay on the vehicle at same lane. Then the probability of taking other lanes vehicle as a hop is always smaller than relaying on same lane vehicle. In addition, the growths from 1 lane to 2 lanes and 2 lanes to 3 lanes are obvious, whereas, after 3 lanes, it is no need to search vehicles on more lanes. More number of lanes does not mean higher maximum connectivity probability, since if a vehicle is in blind area, the other lanes vehicles can be found must be in the coverage gap, one hop rule is not satisfied. And in a 3 lanes scenario, the left and right lane vehicles have same connectivity probability, vehicles in the middle lane have higher probabilities because it is easier to find vehicle at neighbor lane than find vehicle at the third lane.

4.5 Results of BD platoon based model

This section shows the results of different cases in BD platoon based model, each case is compared with a corresponding case in LF model. To make the results more accurate, we assume the ratio of platoon is 1. Table 4.5 gives the parameters used in the simulation.

Table 4.5. All parameter values for different intervals of BSs cases

Parameter	Value
Length of platoon	100
R_1	300
R_2	350, 450, 500
R_d	4150, 4400, 4550, 4800, 5500
R_b	2000
ρ	0→1
Number of lane	1

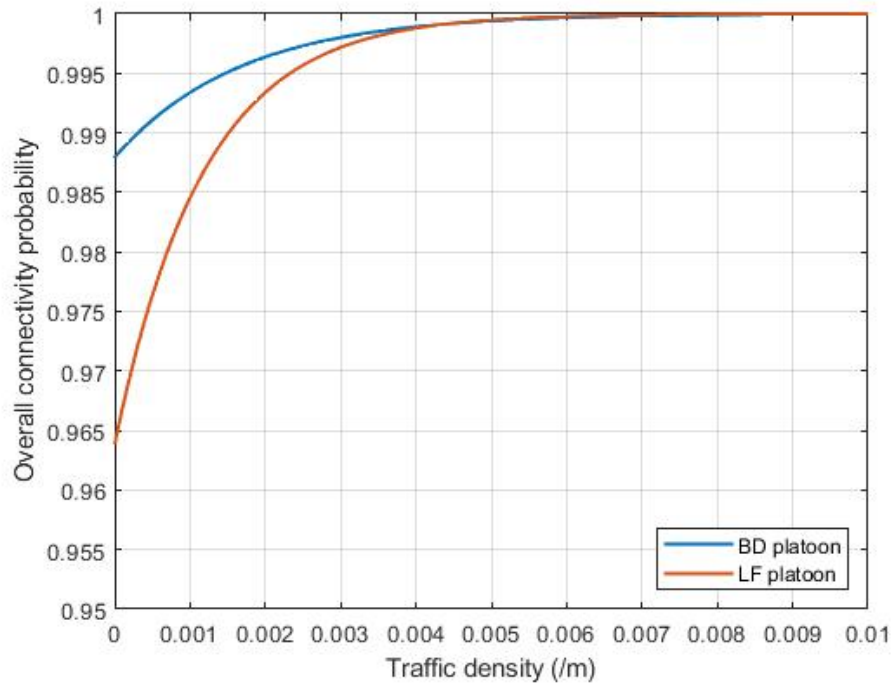

Figure 4.7. $d=150\text{m}$

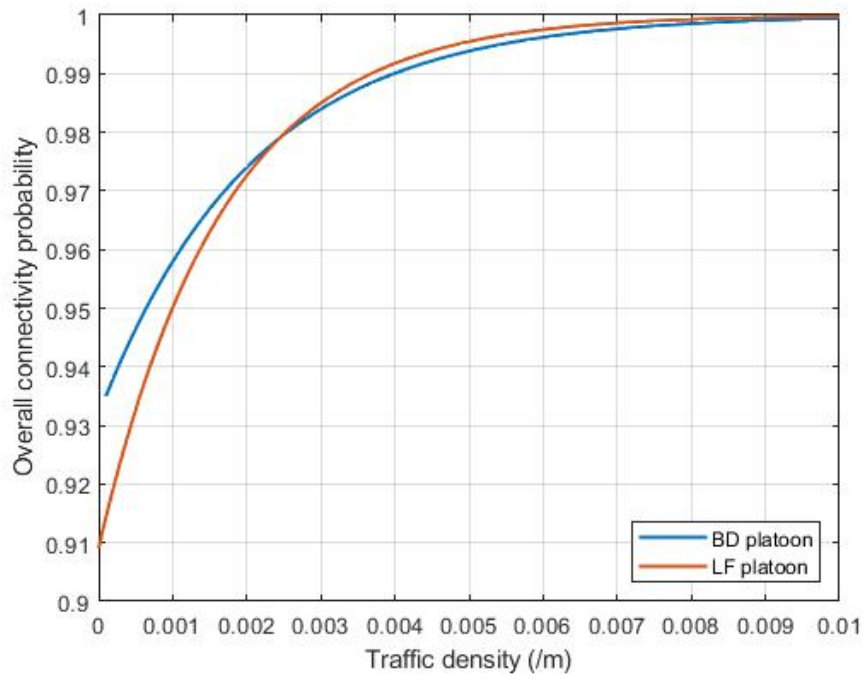

Figure 4.8. $d=400m$

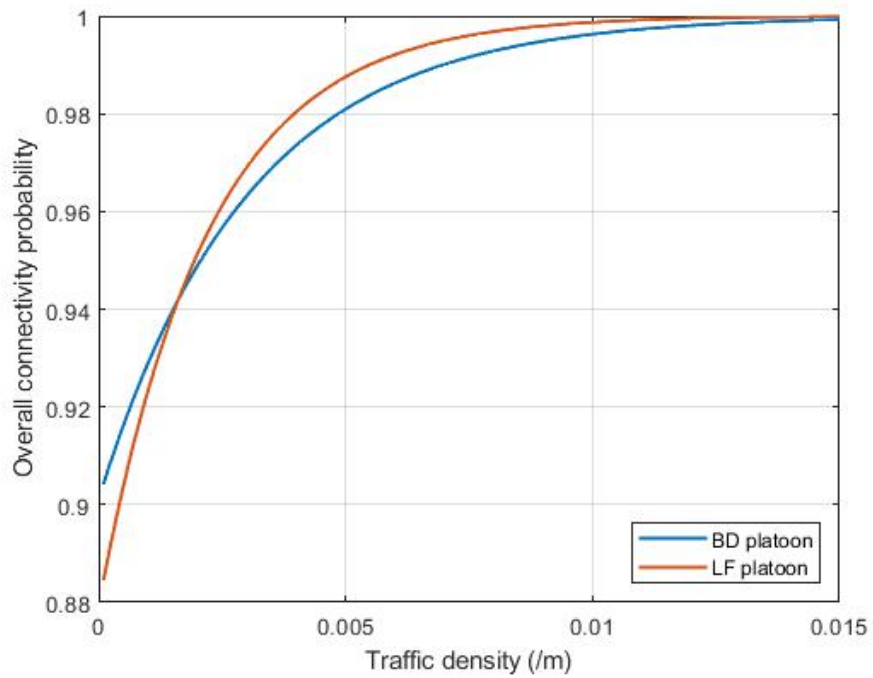

Figure 4.9. $d=550m$

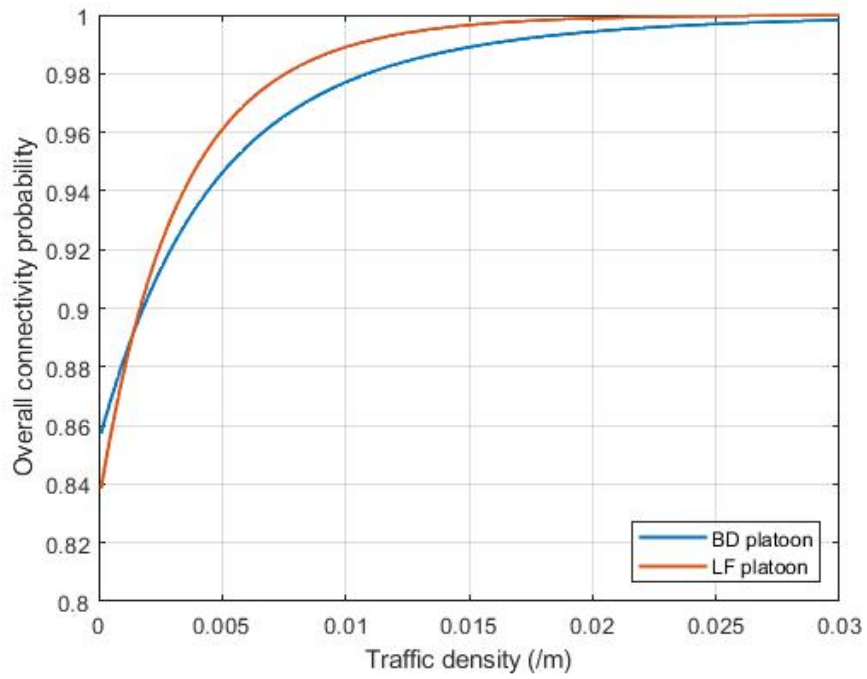

Figure 4.10. $d=800\text{m}$

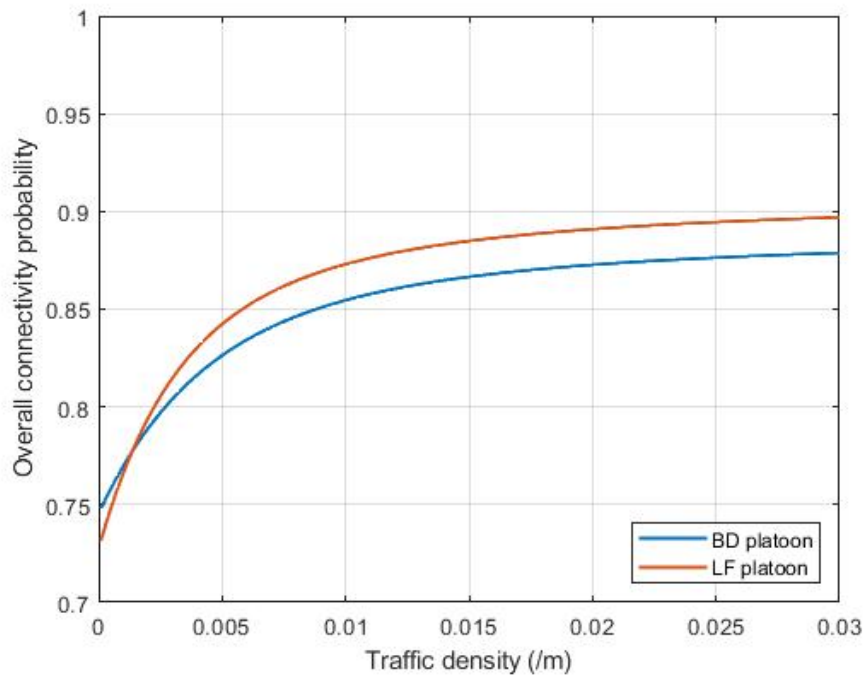

Figure 4.11. $d=1500\text{m}$

As seen in Figure 4.7 to 4.11, the start point of BD platoon is always higher than the start point of LF platoon, which means BD platoon has a high utilization rate for the communication range. When the distance of coverage gap is increasing, two start points is getting closer. Long gap distance will weaken the influence of the length of BD platoon. As the traffic density increases, connectivity probability of LF platoon will exceed the probability of BD platoon. The main reason of this is the difference in communication range. The leader vehicle in the platoon always has a higher communication range than individual vehicle, which allows it to cover more area.

4.6 Relations between two platoons

4.6.1 Communication ranges and length of platoon relations

Followings are the Parameters used in this simulation:

Table 4.6. All parameter values for different intervals of BSs cases

Parameter	Value
Length of platoon	66.6, 100, 133.3
R_1	250, 300, 350
R_2	300, 400, 450, 500
R_d	5500
R_b	2000
ρ	0→1
Number of lane	1

Figure 4.12 depicts the relationship between the length BD platoon and communication range of LF platoon. When R_1 is fixed, lengths of platoon are changed from 66.6 to 133.3. Three BD platoon lanes overlap with three LF platoon lanes. Relationship between these two parameters can be given by:

$$P(1.5\Delta L) = P(\Delta R_2)$$

Similarly, in Figure 4.13. When L is fixed, communication ranges are changed from 250 to 350, three BD platoon lanes overlap with three LF platoon lanes. Relationship between these two parameters can be given by:

$$P(\Delta R_1) = P(\Delta R_2)$$

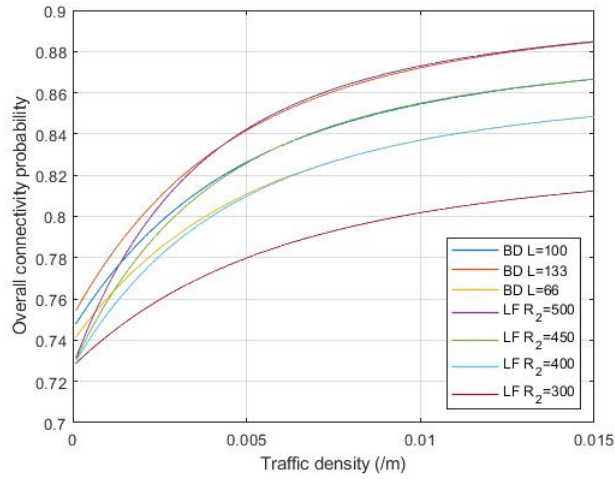

Figure 4.12. Relationship of L and R_2

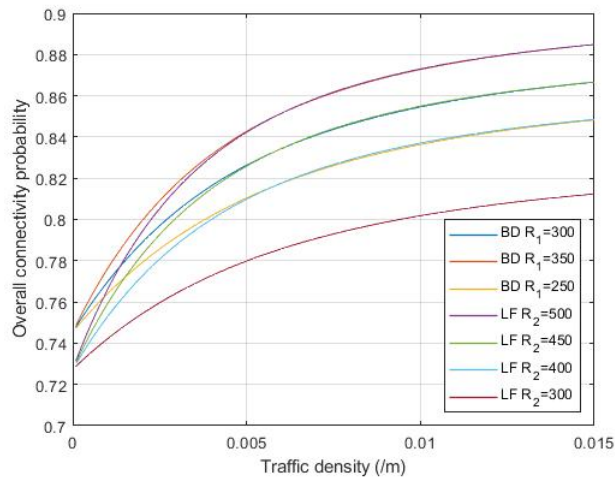

Figure 4.13. Relationship of R_1 and R_2

4.6.2 Performance in two-ways scenario

Followings are the Parameters used in this simulation:

Table 4.7. All parameter values for different intervals of BSs cases

Parameter	Value
Length of platoon	100
R_1	300
R_2	450
R_d	4300
R_b	2000
ρ	0→1
Number of lane	2

This simulation is the result of 2 ways scenario. With $R_2 = 450$, overall probabilities of 2 platoons are similar. It proves the advantage of BD platoon in finding platoon as relay at the second lane. The peak value of blue lane in Figure 4.14 is higher than the red lane.

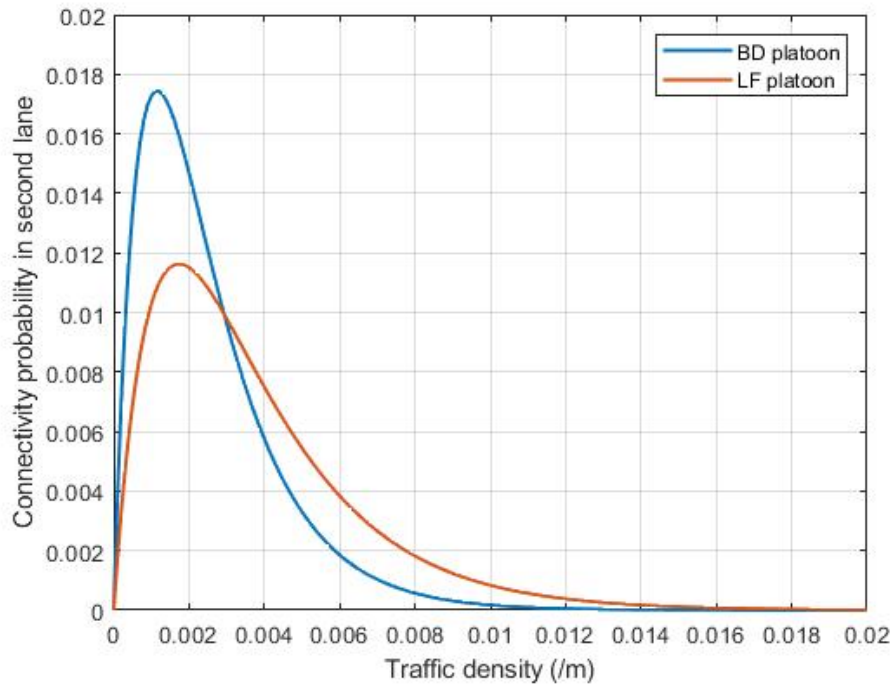

Figure 4.14. Connectivity probabilities of LF and BD platoon at minor lane

5. CONCLUSION AND FUTURE WORKS

5.1 Conclusion

In this thesis, a platoon-based VANETs 2D model was built to analyze the connectivity probability of vehicles in a vehicle-platoon mixed highway environment with two different types of platoons. The thesis was divided into 5 parts. The first chapter gives a brief explanation on VANETs technology and some applications of it. It also mentioned the concept of platoon and how it will benefit the traffic environment. Chapter 1 also explain the need of analyzing the connectivity probability in a platoon-based VANET.

The second chapter introduced VANETs and platoon in details. It discussed two technologies, which are V2V communication and V2I communication in VANETs with their features and applications. Compared them in different environment and explained the relationship between them. Chapter 2 also talked about the platoon. Analyzed stability, tolerance, and communication range of different topology platoons.

In Chapter 3, a platoon based VANETs 2D model was introduced. 5 cases with LF platoon in terms of different coverage gap distance were discussed with corresponding figures. In each case, 6 types of connectivity probability were analyzed, which are individual vehicles and platoons in different area of highway: Area in transmission range of BS, coverage gap area of major lane, coverage gap area of minor lane. Overall connectivity probability was also given in Chapter 3. In addition, 6 cases with BD platoon were also discussed in same way. A comparison was given at the end of this chapter.

Matlab simulation results were shown in Chapter 4. For LF platoon based model, besides the original situations, other parameters (e.g., traffic density, ratio of platoons, number of lanes) were considered in this chapter. Each section describes the corresponding factor effectiveness of improving connectivity probability. In BD platoon based model, each case is shown with a LF platoon based scenario under same system parameters. Relationships between two platoons are also found.

Chapter 5 provides the summary and future work of this thesis. Results of this paper can help design the distribution of BSs in ultra-dense cellular networks in future. An appropriate distance between two BSs can be given according to real scenario. And the traffic density is

determined by different area, the analysis of it will help to find proper parameters to build VANETs. Simulation of different lanes shows that 3 lanes design is the most effective way to improve the connectivity probability. Finally, all results prove that increasing the ratio of platoon is the best way. For a given requirement of connectivity probability, different type of platoons can be chosen according to system parameters.

5.2 Future works

The future work of this project is itemized below:

- Use other types of platoon topologies, such as predecessor following topology
- Multiple hops cases can be considered while in a long coverage gap distance scenario
- Distribution of base stations can be in 2-dimensional
- An auto selection system can be implemented to switch hop while a more appropriate vehicle appears in transmission range
- Introduce disrupted communication channel to this model to test the influence of interrupted signals

REFERENCES

- [1] R. Hall and C. Chin, "Vehicle sorting for platoon formation: Impacts on highway entry and throughput," *Transportation Research Part C: Emerging Technologies*, pp. 405–420, 2005.
- [2] J. Zhao, Q. Li, Y. Gong, and K. Zhang, "Computation offloading and resource allocation for cloud assisted mobile edge computing in vehicular networks," *IEEE Transactions on Vehicular Technology*, vol. 68, no. 8, pp. 7944–7956, 2019. DOI: [10.1109/TVT.2019.2917890](https://doi.org/10.1109/TVT.2019.2917890).
- [3] S. Ni, J. Zhao, H. H. Yang, and Y. Gong, "Enhancing downlink transmission in mimo hetnet with wireless backhaul," *IEEE Transactions on Vehicular Technology*, vol. 68, no. 7, pp. 6817–6832, 2019. DOI: [10.1109/TVT.2019.2918574](https://doi.org/10.1109/TVT.2019.2918574).
- [4] Y. Li, J. Liao, T. Li, X. Zhu, L. Zhang, and S. Xie, "Several statistical parameters for one-dimensional vehicular ad hoc networks," *2010 2nd IEEE International Conference on Network Infrastructure and Digital Content*, pp. 709–712, 2010. DOI: [10.1109/ICNIDC.2010.5657980](https://doi.org/10.1109/ICNIDC.2010.5657980).
- [5] Z. Yan, H. Jiang, Z. Shen, Y. Chang, and L. Huang, " k -connectivity analysis of one-dimensional linear vanets," in *IEEE Transactions on Vehicular Technology*, pp. 426–433, 2012. DOI: [10.1109/TVT.2011.2176969](https://doi.org/10.1109/TVT.2011.2176969).
- [6] Z. Wang, J. Zheng, and Y. Wu, "Analysis of the downlink connectivity probability within the two-hop coverage of an rsu in vanet," in *2017 IEEE 85th Vehicular Technology Conference (VTC Spring)*, 2017, pp. 1–5. DOI: [10.1109/VTCSpring.2017.8108454](https://doi.org/10.1109/VTCSpring.2017.8108454).
- [7] C. Li, A. Zhen, M. Z. J. Su and, and X. Hu, "Analysis of connectivity probability in vanets considering minimum safety distance," *2016 8th International Conference on Wireless Communications Signal Processing (WCSP)*, pp. 1–5, 2016. DOI: [10.1109/WCSP.2016.7752513](https://doi.org/10.1109/WCSP.2016.7752513).
- [8] F. Li, W. Chen, and Y. Shui, "Study on connectivity probability of vanets under adverse weather conditions at 5.9 ghz," in *IEEE Access*, pp. 547–555, 2020. DOI: [10.1109/ACCESS.2019.2962089](https://doi.org/10.1109/ACCESS.2019.2962089).
- [9] S. Yousefi, E. Altman, R. El-Azouzi, and M. Fathy, "Analytical model for connectivity in vehicular ad hoc networks," in *IEEE Transactions on Vehicular Technology*, pp. 3341–3356, 2008. DOI: [10.1109/TVT.2008.2002957](https://doi.org/10.1109/TVT.2008.2002957).

- [10] C. Shao, S. Leng, Y. Zhang, A. Vinel, and M. Jonsson, “Performance analysis of connectivity probability and connectivity-aware mac protocol design for platoon-based vanets,” in *IEEE Transactions on Vehicular Technology*, pp. 5596–5609, 2015. DOI: [10.1109/TVT.2015.2479942](https://doi.org/10.1109/TVT.2015.2479942).
- [11] C. Bian, J. Zhao, X. Sun, X. Li, and D. Zou, “Network connectivity performance analysis of platoon-based vehicular ad-hoc network on a two-way lane,” in *2019 IEEE International Conference on Signal, Information and Data Processing (ICSIDP)*, 2019, pp. 1–5. DOI: [10.1109/ICSIDP47821.2019.9173276](https://doi.org/10.1109/ICSIDP47821.2019.9173276).
- [12] C. K. Toh, *Ad Hoc Mobile Wireless Networks: Protocols and Systems*. Prentice Hall, Dec. 3, 2001, ISBN: 9780132442046.
- [13] G. K. et al, “Vehicular networking: A survey and tutorial on requirements, architectures, challenges, standards and solutions,” in *IEEE Communications Surveys Tutorials*, pp. 584–616, 2011. DOI: [10.1109/SURV.2011.061411.00019](https://doi.org/10.1109/SURV.2011.061411.00019).
- [14] *V2X: The basics of connected vehicle technology*. [Online]. Available: <https://www.intellias.com/v2x-basics-connected-vehicle-technology/> (Last Accessed: 06/01/2021).
- [15] *Research Gate*. [Online]. Available: https://www.researchgate.net/figure/Vehicle-to-Infrastructure-V2I-communication_fig1_309546589 (Last Accessed: 06/01/2021).
- [16] M. Kihl, K. Bür, P. Mahanta, and E. Coelingh, “3gpp lte downlink scheduling strategies in vehicle-to-infrastructure communications for traffic safety applications,” *2012 IEEE Symposium on Computers and Communications (ISCC)*, pp. 000 448–000 453, 2012. DOI: [10.1109/ISCC.2012.6249337](https://doi.org/10.1109/ISCC.2012.6249337).
- [17] U. Department of Transportation. (Mar. 8, 2013). “Vehicle-to-infrastructure (v2i) safety applications,” [Online]. Available: https://rosap.nhtl.bts.gov/view/dot/26500/dot_26500_DS1.pdf (Last Accessed: 06/05/2021).
- [18] *Research Gate*. [Online]. Available: https://www.researchgate.net/figure/VANET-communication-architecture_fig3_330772224 (Last Accessed: 06/02/2021).
- [19] T. Dekho. (Jan. 18, 2016). “Truck platooning: History, benefits, future,” [Online]. Available: <https://trucks.cardekho.com/en/news/detail/truck-platooning-history-benefits-future-945.html> (Last Accessed: 06/05/2021).
- [20] U. Department of Transportation. (Jan. 9, 2018). “Truck platooning the state of the industry and future research topics,” [Online]. Available: <https://www.fmcsa.dot.gov/sites/fmcsa.dot.gov/files/docs/safety/395146/loftus-tershak-truck-platooning-final-508c.pdf> (Last Accessed: 06/05/2021).

- [21] *Wikimedia Commons*. [Online]. Available: https://commons.wikimedia.org/wiki/File:Platooning_Back_022414_Final_noTpye.jpg (Last Accessed: 06/02/2021).
- [22] B. van Arem, C. J. G. van Driel, and R. Visser, “The impact of cooperative adaptive cruise control on traffic-flow characteristics,” *IEEE Transactions on Intelligent Transportation Systems*, vol. 7, no. 4, pp. 429–436, 2006. DOI: [10.1109/TITS.2006.884615](https://doi.org/10.1109/TITS.2006.884615).
- [23] B. Kaiser, *Research Gate*. [Online]. Available: <https://www.researchgate.net/profile/Bernhard-Kaiser-6> (Last Accessed: 06/02/2021).
- [24] C. Li, D. He, A. Zhen, J. Sun, and X. Hu, “Enhancing v2v network connectivity for road safety by platoon-based vanets,” in *2017 IEEE International Conference on Consumer Electronics (ICCE)*, 2017, pp. 273–274. DOI: [10.1109/ICCE.2017.7889315](https://doi.org/10.1109/ICCE.2017.7889315).
- [25] P. Seiler, A. Pant, and K. Hedrick, “Disturbance propagation in vehicle strings,” *IEEE Transactions on Automatic Control*, vol. 49, no. 10, pp. 1835–1842, 2004. DOI: [10.1109/TAC.2004.835586](https://doi.org/10.1109/TAC.2004.835586).
- [26] P. Barooah and J. Hespanha, “Error amplification and disturbance propagation in vehicle strings with decentralized linear control,” in *Proceedings of the 44th IEEE Conference on Decision and Control*, 2005, pp. 4964–4969. DOI: [10.1109/CDC.2005.1582948](https://doi.org/10.1109/CDC.2005.1582948).
- [27] S. Keykhaie and A. Mahmoudifar, “Study of connectivity in a vehicular ad hoc network with random node speed distribution,” *2014 6th International Conference on New Technologies, Mobility and Security (NTMS)*, pp. 1–4, 2014. DOI: [10.1109/NTMS.2014.6814051](https://doi.org/10.1109/NTMS.2014.6814051).